

Service Manual



SPG 422 Component Digital Sync Generator S/N B020000 through S/N B033999

071-0035-02

Warning

The servicing instructions are for use by qualified personnel only. To avoid personal injury, do not perform any servicing unless you are qualified to do so. Refer to all safety summaries prior to performing service.

Copyright © Tektronix, Inc. All rights reserved.

Tektronix products are covered by U.S. and foreign patents, issued and pending. Information in this publication supercedes that in all previously published material. Specifications and price change privileges reserved.

Printed in the U.S.A.

Tektronix, Inc., P.O. Box 1000, Wilsonville, OR 97070-1000

TEKTRONIX and TEK are registered trademarks of Tektronix, Inc.

WARRANTY

Tektronix warrants that the products that it manufactures and sells will be free from defects in materials and workmanship for a period of one (1) year from the date of shipment. If a product proves defective during this warranty period, Tektronix, at its option, either will repair the defective product without charge for parts and labor, or will provide a replacement in exchange for the defective product.

In order to obtain service under this warranty, Customer must notify Tektronix of the defect before the expiration of the warranty period and make suitable arrangements for the performance of service. Customer shall be responsible for packaging and shipping the defective product to the service center designated by Tektronix, with shipping charges prepaid. Tektronix shall pay for the return of the product to Customer if the shipment is to a location within the country in which the Tektronix service center is located. Customer shall be responsible for paying all shipping charges, duties, taxes, and any other charges for products returned to any other locations.

This warranty shall not apply to any defect, failure or damage caused by improper use or improper or inadequate maintenance and care. Tektronix shall not be obligated to furnish service under this warranty a) to repair damage resulting from attempts by personnel other than Tektronix representatives to install, repair or service the product; b) to repair damage resulting from improper use or connection to incompatible equipment; c) to repair any damage or malfunction caused by the use of non-Tektronix supplies; or d) to service a product that has been modified or integrated with other products when the effect of such modification or integration increases the time or difficulty of servicing the product.

THIS WARRANTY IS GIVEN BY TEKTRONIX IN LIEU OF ANY OTHER WARRANTIES, EXPRESS OR IMPLIED. TEKTRONIX AND ITS VENDORS DISCLAIM ANY IMPLIED WARRANTIES OF MERCHANTABILITY OR FITNESS FOR A PARTICULAR PURPOSE. TEKTRONIX' RESPONSIBILITY TO REPAIR OR REPLACE DEFECTIVE PRODUCTS IS THE SOLE AND EXCLUSIVE REMEDY PROVIDED TO THE CUSTOMER FOR BREACH OF THIS WARRANTY. TEKTRONIX AND ITS VENDORS WILL NOT BE LIABLE FOR ANY INDIRECT, SPECIAL, INCIDENTAL, OR CONSEQUENTIAL DAMAGES IRRESPECTIVE OF WHETHER TEKTRONIX OR THE VENDOR HAS ADVANCE NOTICE OF THE POSSIBILITY OF SUCH DAMAGES.

Table of Contents

	General Safety Summary	vii
	Service Safety Summary	ix
	Preface	xi
Specifications		
	Product Description	1-1
	Characteristics Tables	1-2
	Signal Illustrations	1-24
Operating Information		
	Functional Overview	2-1
	Genlock	2-1
	Genlock Video Standard	2-1
	Genlock Input Configuration	2-2
	Genlock Timing	2-2
	Black Signals	2-3
	Bars Signals	2-3
	Serial Black	2-3
	Audio Signals	2-4
	Serial Signals (Option 2 only)	2-4
Theory of Operation		
	Genlock	3-1
	Front Panel Board	3-1
	Digital Board	3-3
	Output Board	3-4
	Power Supply	3-6
	Option 1 Board	3-6
	Option 2 Board	3-7
	Detailed Circuit Descriptions	3-7
	Output Board	3-10
	Power Supply	3-15
	Option 1 Board	3-21
	Option 2 Board	3-23
Performance Verification		
	Equipment Required	4-1
	Calibration Data Report	4-3
	Performance Verification Procedure	4-11
Adjustment Procedures		
	Summary Adjustment	5-1
	Adjustment Procedure	5-2

Maintenance

Service Options	6-1
Preparation	6-1
Preventive Maintenance	6-1
Service Setups	6-2
Configuring the Remote	6-2
Inspection and Cleaning	6-2
Corrective Maintenance	6-5
Tektronix Service Offerings	6-6
Repackaging Instructions	6-13

Options

Power Cord Options	7-1
Ordering	7-2

Replaceable Electrical Parts

Parts Ordering Information	8-1
Using the Replaceable Electrical Parts List	8-1

Diagrams

Replaceable Mechanical Parts

Parts Ordering Information	10-1
Using the Replaceable Mechanical Parts List	10-1

List of Figures

Figure 1–1: Timing relationship between digital video data and analog line synchronization (reference for line scanning) in the 525/60 system	1–4
Figure 1–2: Timing relationship between digital video data and analog line synchronization (reference for line scanning) in the 625/50 system	1–4
Figure 1–3: Relationship between digital and analog fields, showing also the position of the digital field-blanking interval in the 625 system	1–5
Figure 1–4: Relationship of video data/vertical sync, in 525 system .	1–6
Figure 1–5: 60 Hz black burst with 7.5 IRE setup	1–10
Figure 1–6: 60 Hz black burst with no setup	1–11
Figure 1–7: 50 Hz black burst	1–11
Figure 1–8: 75% Color bars — Y channel	1–24
Figure 1–9: 75% Color bars — CB channel	1–24
Figure 1–10: 75% Color bars — CR channel	1–25
Figure 1–11: 100% Color bars — Y channel	1–25
Figure 1–12: 100% Color bars — CB channel	1–26
Figure 1–13: 100% Color bars — CR channel	1–26
Figure 1–14: 100% Red — Y channel	1–27
Figure 1–15: 100% Red — CB channel	1–27
Figure 1–16: 100% Red — CR channel	1–28
Figure 1–17: EIA bars (part of SMPTE bars) — Y channel	1–28
Figure 1–18: EIA bars (part of SMPTE bars) — CB channel	1–29
Figure 1–19: EIA bars (part of SMPTE bars) — CR channel	1–29
Figure 1–20: IWQ bars (part of SMPTE bars) — Y channel	1–30
Figure 1–21: IWQ bars (part of SMPTE bars) — CB channel	1–30
Figure 1–22: IWQ bars (part of SMPTE bars) — CR channel	1–31
Figure 1–23: Reverse bars (part of SMPTE bars) — Y channel	1–31
Figure 1–24: Reverse bars (part of SMPTE bars) — CB channel ...	1–32
Figure 1–25: Reverse bars (part of SMPTE bars) — CR channel ...	1–32
Figure 1–26: Multiburst — Y channel	1–33
Figure 1–27: Multiburst for CB	1–33
Figure 1–28: Multiburst for CB and CR	1–34
Figure 1–29: Modulated pulse and bar — Y channel	1–34
Figure 1–30: Modulated pulse and bar for CB	1–35

Figure 1–31: Modulated pulse and bar for CR	1–35
Figure 1–32: Convergence (horizontal) — Y channel	1–36
Figure 1–33: Convergence (horizontal) — CB and CR channels	1–36
Figure 1–34: Convergence (vertical) — Y channel	1–37
Figure 1–35: Convergence (vertical) — CB and CR channels	1–37
Figure 1–36: Active picture markers (part of active picture timing test signal) — Y channel	1–38
Figure 1–37: Active picture markers (part of active picture timing test signal) — CB	1–38
Figure 1–38: Active picture markers (part of active picture timing test signal) — CR	1–39
Figure 1–39: White bar (part of active picture timing test signal) — Y channel	1–39
Figure 1–40: White bar (part of active picture timing test signal) — CB and CR channels	1–40
Figure 1–41: Bowtie sweep — Y channel	1–40
Figure 1–42: Bowtie — CB and CR channels	1–41
Figure 1–43: Bowtie markers — Y channel	1–41
Figure 1–44: Ramp — Y channel	1–42
Figure 1–45: Ramp — CB channel	1–42
Figure 1–46: Ramp — CR channel	1–43
Figure 1–47: Pluge — Y channel	1–43
Figure 1–48: Pluge — CB and CR channels	1–44
Figure 2–1: SPG 422 front panel	2–1
Figure 2–2: Various ways genlock input can be configured	2–2
Figure 2–3: Illustration of SPG 422 timing	2–4
Figure 3–1: SPG 422 block diagram	3–2
Figure 3–2: Block diagram of genlock Input <1>	3–11
Figure 3–3: Block diagram of burst and sync locks <2>	3–12
Figure 3–4: Power inductor circuit	3–17
Figure 3–5: Pulse width modulator and error amplifier circuit	3–19
Figure 4–1: Setup to check serial digital video signals	4–11
Figure 4–2: Various parts of the serial data stream	4–13
Figure 4–3: Setup required to check for an embedded audio signal .	4–14
Figure 4–4: Setup to check accuracy of serial audio signals	4–16
Figure 4–5: Setup to check serial audio signal	4–17
Figure 4–6: Setup to check NTSC analog black outputs	4–20

Figure 4-7: Setup to check PAL analog black outputs	4-26
Figure 4-8: Setup to check the oscillator frequency	4-32
Figure 4-9: Setup to check some genlock functions	4-33
Figure 4-10: Setup to check burst lock phase change	4-37
Figure 4-11: Setup to check genlock with hum	4-39
Figure 4-12: Setup to check isolation	4-40
Figure 4-13: Basic setup for return loss checks	4-42
Figure 5-1: Setup for sync tip adjustment	5-4

List of Tables

Table 1–1: Encoding parameters for serial digital video outputs . . .	1–2
Table 1–2: Timing relationships for serial digital video outputs	1–3
Table 1–3: Output characteristics for serial digital video signals . . .	1–7
Table 1–4: Signal characteristics for analog black outputs (in base instrument only)	1–7
Table 1–5: Signal characteristics for analog black outputs (in Option 1 only)	1–9
Table 1–6: Signal characteristics for serial bars output	1–12
Table 1–7: Signal characteristics for serial test signal (Option 2 only)	1–13
Table 1–8: Signal characteristics for AES/EBU serial digital audio outputs (XLR connectors)	1–14
Table 1–9: Signal characteristics for AES/EBU serial digital audio outputs (BNC outputs)	1–14
Table 1–10: Signal characteristics for embedded serial audio	1–15
Table 1–11: 20-bit audio signal sample distribution for embedded serial audio on 525/59.94 signals	1–16
Table 1–12: 20-bit audio signal sample distribution for embedded serial audio on 625/50 signals	1–16
Table 1–13: Audio channel status bits (serial and embedded audio data streams)	1–18
Table 1–14: Genlock function	1–19
Table 1–15: Power Supply	1–20
Table 1–16: Mechanical (physical) characteristics	1–21
Table 1–17: Environmental characteristics	1–21
Table 1–18: Certifications and compliances	1–22
Table 4–1: List of required equipment	4–2
Table 6–1: Relative susceptibility levels	6–3
Table 6–2: Diagnostic LEDs	6–9
Table 6–3: Diagnostic switch	6–10

General Safety Summary

Review the following safety precautions to avoid injury and prevent damage to this product or any products connected to it. To avoid potential hazards, use this product only as specified.

Only qualified personnel should perform service procedures.

To Avoid Fire or Personal Injury

Use Proper Power Cord. Use only the power cord specified for this product and certified for the country of use.

Use Proper Voltage Setting. Before applying power, ensure that the line selector is in the proper position for the power source being used.

Connect and Disconnect Properly. Do not connect or disconnect probes or test leads while they are connected to a voltage source.

Ground the Product. This product is grounded through the grounding conductor of the power cord. To avoid electric shock, the grounding conductor must be connected to earth ground. Before making connections to the input or output terminals of the product, ensure that the product is properly grounded.

Observe All Terminal Ratings. To avoid fire or shock hazard, observe all ratings and markings on the product. Consult the product manual for further ratings information before making connections to the product.

The common terminal is at ground potential. Do not connect the common terminal to elevated voltages.

Replace Batteries Properly. Replace batteries only with the proper type and rating specified.

Recharge Batteries Properly. Recharge batteries for the recommended charge cycle only.

Use Proper AC Adapter. Use only the AC adapter specified for this product.

Do Not Operate Without Covers. Do not operate this product with covers or panels removed.

Use Proper Fuse. Use only the fuse type and rating specified for this product.

Avoid Exposed Circuitry. Do not touch exposed connections and components when power is present.

Wear Eye Protection. Wear eye protection if exposure to high-intensity rays or laser radiation exists.

Do Not Operate With Suspected Failures. If you suspect there is damage to this product, have it inspected by qualified service personnel.

Do Not Operate in Wet/Damp Conditions.

Do Not Operate in an Explosive Atmosphere.

Keep Product Surfaces Clean and Dry.

Provide Proper Ventilation. Refer to the manual's installation instructions for details on installing the product so it has proper ventilation.

Symbols and Terms

Terms in this Manual. These terms may appear in this manual:



WARNING. *Warning statements identify conditions or practices that could result in injury or loss of life.*



CAUTION. *Caution statements identify conditions or practices that could result in damage to this product or other property.*

Terms on the Product. These terms may appear on the product:

DANGER indicates an injury hazard immediately accessible as you read the marking.

WARNING indicates an injury hazard not immediately accessible as you read the marking.

CAUTION indicates a hazard to property including the product.

Symbols on the Product. The following symbols may appear on the product:



WARNING
High Voltage



Protective Ground
(Earth) Terminal



CAUTION
Refer to Manual



Double
Insulated

Service Safety Summary

Only qualified personnel should perform service procedures. Read this *Service Safety Summary* and the *General Safety Summary* before performing any service procedures.

Do Not Service Alone. Do not perform internal service or adjustments of this product unless another person capable of rendering first aid and resuscitation is present.

Disconnect Power. To avoid electric shock, disconnect the mains power by means of the power cord or, if provided, the power switch.

Use Caution When Servicing the CRT. To avoid electric shock or injury, use extreme caution when handling the CRT. Only qualified personnel familiar with CRT servicing procedures and precautions should remove or install the CRT.

CRTs retain hazardous voltages for long periods of time after power is turned off. Before attempting any servicing, discharge the CRT by shorting the anode to chassis ground. When discharging the CRT, connect the discharge path to ground and then the anode. Rough handling may cause the CRT to implode. Do not nick or scratch the glass or subject it to undue pressure when removing or installing it. When handling the CRT, wear safety goggles and heavy gloves for protection.

Use Care When Servicing With Power On. Dangerous voltages or currents may exist in this product. Disconnect power, remove battery (if applicable), and disconnect test leads before removing protective panels, soldering, or replacing components.

To avoid electric shock, do not touch exposed connections.

X-Radiation. To avoid x-radiation exposure, do not modify or otherwise alter the high-voltage circuitry or the CRT enclosure. X-ray emissions generated within this product have been sufficiently shielded.

Preface

This manual provides servicing information for the SPG 422 Component Digital Sync Generator with serial numbers (S/N) B02000 through B033999. Procedures in this manual are designed for experienced service technicians.

About This Manual

This manual is composed of the following sections:

- *Specifications* provides a list of all instrument performance requirements, operating environment requirements, and certifications.
- *Operating Information* provides an overview of the main instrument features.
- *Theory of Operation* provides a block diagram description of the instrument circuits.
- *Performance Verification* provides a manual procedure for verifying the performance requirements in the *Specifications* section.
- *Adjustment Procedures* provides an automated procedure for adjusting the generator following repair.
- *Maintenance* provides instructions for troubleshooting and replacing instrument modules.
- *Options* provides a list of the available product options.
- *Replaceable Electrical Parts* provides a list of all electrical components used in the instrument.
- *Diagrams* provides block diagrams, component locators, and schematics.
- *Replaceable Mechanical Parts* provides a list of all mechanical parts and electrical modules not contained on a circuit board.

Contacting Tektronix

Product Support	<p>For questions about using Tektronix measurement products, call toll free in North America: 1-800-TEK-WIDE (1-800-835-9433 ext. 2400) 6:00 a.m. – 5:00 p.m. Pacific time</p> <p>Or contact us by e-mail: tm_app_supp@tek.com</p> <p>For product support outside of North America, contact your local Tektronix distributor or sales office.</p>
Service Support	<p>Tektronix offers extended warranty and calibration programs as options on many products. Contact your local Tektronix distributor or sales office.</p> <p>For a listing of worldwide service centers, visit our web site.</p>
For other information	<p>In North America: 1-800-TEK-WIDE (1-800-835-9433) An operator will direct your call.</p>
To write us	<p>Tektronix, Inc. 14200 SW Karl Braun Drive Beaverton, OR 97077 USA</p>
Website	<p>Tektronix.com</p>

Specifications

This section contains specifications and signal illustrations for the SPG 422.

The items listed in the following tables describe the performance of the SPG 422 Component Digital Sync Generator. Performance Requirements are generally quantitative and can be tested by a Performance Verification procedure contained in the Service Section of this manual.

Supplemental Information is valuable data pertaining to the operation and output capabilities of this instrument. Only a few items listed in this category are testable in the Performance Verification procedure.

Performance Conditions – The requirements listed in the electrical specification portion of these specifications apply over an ambient temperature range of 0° C to +40° C. The rated accuracies are valid when the instrument is calibrated at an ambient temperature range of +20° C to +30° C, after a warm-up time of 20 minutes. Test equipment used to verify Performance Requirements must be calibrated and working within the limits specified under the Equipment Required list.

These instruments are intended to operate from an AC power source that will not apply more than 250 V_{RMS} between the supply conductors or either supply conductor and ground. A protective ground connection by way of the grounding conductor is essential for safe operation.

Environmental specifications are listed toward the back of the following tables. In addition a list of appropriate safety and electromagnetic interference (EMI) standards also can be found there.

Product Description

The SPG 422 is a component digital sync pulse generator (SPG). The SPG 422 provides basic setup and timing signals for component digital tape recorders and processing equipment systems. It provides audio tones and a few simple video test signals needed to adjust equipment and stripe video tapes. Analog black signals are the timing reference signals of choice and the SPG 422 provides six analog black signals each with separate timing controls. Because the SPG 422 has good frequency stability, it can perform as a stand-alone generator or genlock to an external PAL or NTSC signal.

Some installations use 525/59.94 and 625/50 component signals simultaneously or switch between standards regularly. Dual-standard operation is possible with the SPG 422 architecture. Also important for dual-standard operation, is the ability of the SPG 422 to output audio tones locked to the video standard(s) in use.

The SPG 422 has a front-panel interface that controls all instrument functions. Also, the user can control the SPG 422 via either a parallel ground-closure remote or RS-232. The ground-closure remote provides simple control of a few major instrument functions, while the RS-232 implementation is a SCPI (Standard Commands for Programmable Instruments) command language interface, with most of the front-panel interface capabilities. (Not all commands are implemented to avoid operator traps.)

Characteristics Tables

Table 1–1: Encoding parameters for serial digital video outputs

Characteristics	Supplemental information	
Standards Conformance	ITU-R BT.601 and ITU-R BT.656, SMPTE 125M, EBU Tech. 3267-E	
Coded Signals	Luminance (Y), and color difference (C _r and C _b)	
Number of Samples per Video Line	<i>525/59.94</i>	<i>625/50</i>
Luminance (Y)	858	864
Color Difference (C _r and C _b)	429	432
Sampling Structure	Orthogonal: line, field, and frame repetitive. C _r and C _b samples are co-sited with odd Y samples in each line.	
Sampling Frequency		
Luminance (Y)	13.5 MHz nominal	
Color Difference (C _r and C _b)	6.75 MHz nominal	
Signal Coding	Uniformly quantized PCM, 10 bits per sample, for each luminance and color-difference signal.	
Number of Samples per Digital Active Line	<i>525/59.94</i>	<i>625/50</i>
Luminance (Y)	720	720
Color Difference (C _r and C _b)	360	360
Correspondence Between Video Signal Levels and Quantization Levels		
Luminance (Y)	877 quantization levels, with black level corresponding to level 64 and the peak white level corresponding to level 940.	
Color Difference (C _r and C _b)	897 quantization levels symmetrically distributed around level 512, which corresponds to zero signal.	

Table 1-2: Timing relationships for serial digital video outputs

Characteristics	Supplemental information						
Standards Conformance	ITU-R BT.601 and ITU-R BT.656, SMPTE 125M, EBU Tech. 3267-E						
Line Timing							
525/59.94	See Figure 1-1.						
625/50	See Figure 1-2.						
Field Timing							
625/50	See Figure 1-3.						
525/59.94	See Figure 1-4.						
Timing Reference Signal	<i>Bit</i>	<i>1st Word</i>	<i>2nd Word</i>	<i>3rd Word</i>	<i>4th Word</i>		
End of Active Video/Start of Active Video (EAV/SAV)	9	1	0	0	1		
	8	1	0	0	F		
	7	1	0	0	V		
	6	1	0	0	H		
	5	1	0	0	P3		
	4	1	0	0	P2		
	3	1	0	0	P1		
	2	1	0	0	P0		
	1	1	0	0	0		
	0	1	0	0	0		
	where:						
	F = 1 during field 2,						
	V = 1 during vertical blanking,						
	H = 1 during horizontal blanking,						
	The protection bits are:						
	F	V	H	P3	P2	P1	P0
	0	0	0	0	0	0	0
	0	0	1	1	1	0	1
	0	1	0	1	0	1	1
	0	1	1	0	1	1	0
	1	0	0	0	1	1	1
	1	0	1	1	0	1	0
	1	1	0	1	1	0	0
	1	1	1	0	0	0	1

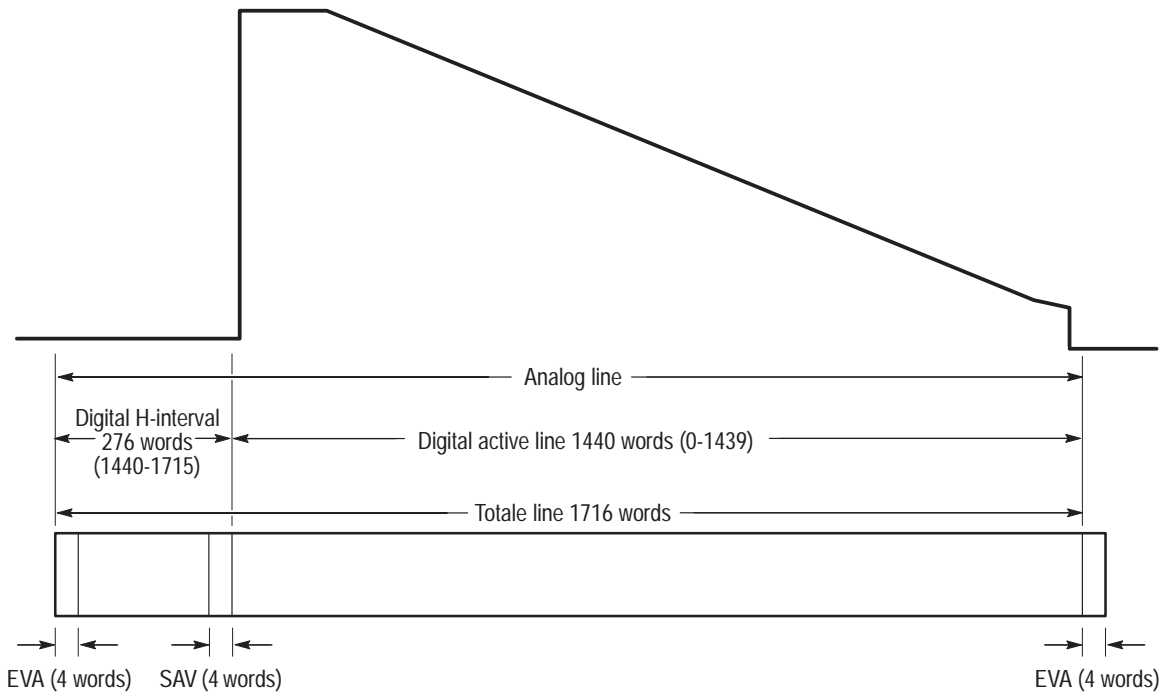

Figure 1-1: Timing relationship between digital video data and analog line synchronization (reference for line scanning) in the 525/60 system

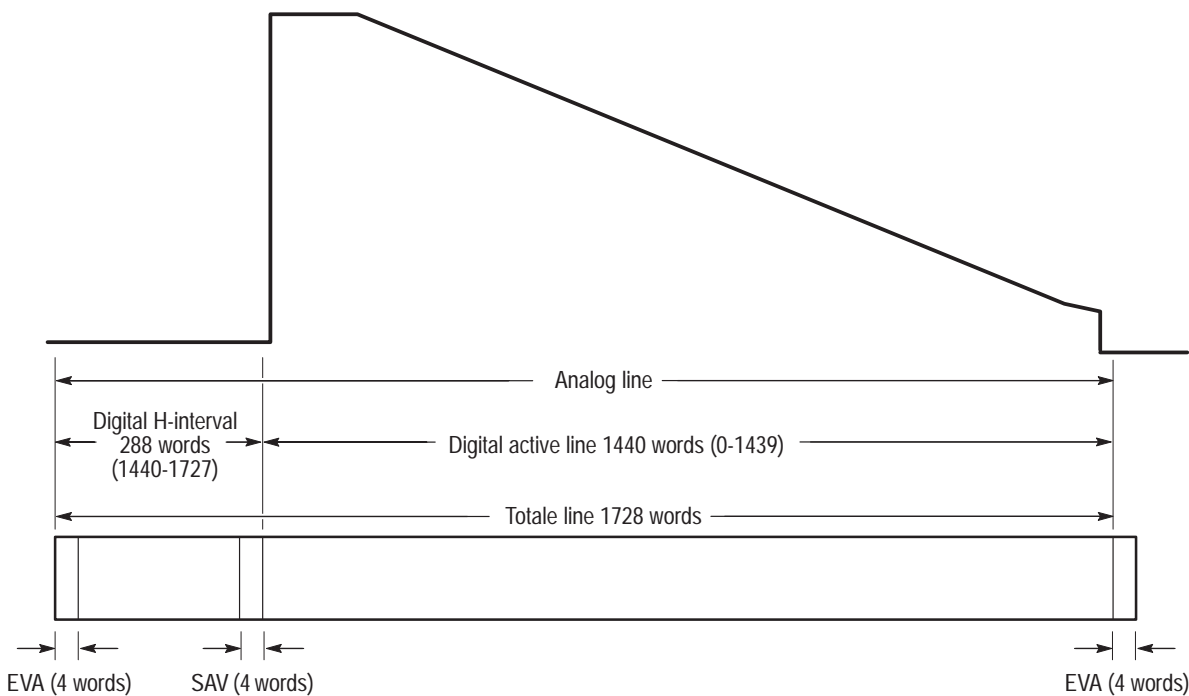

Figure 1-2: Timing relationship between digital video data and analog line synchronization (reference for line scanning) in the 625/50 system

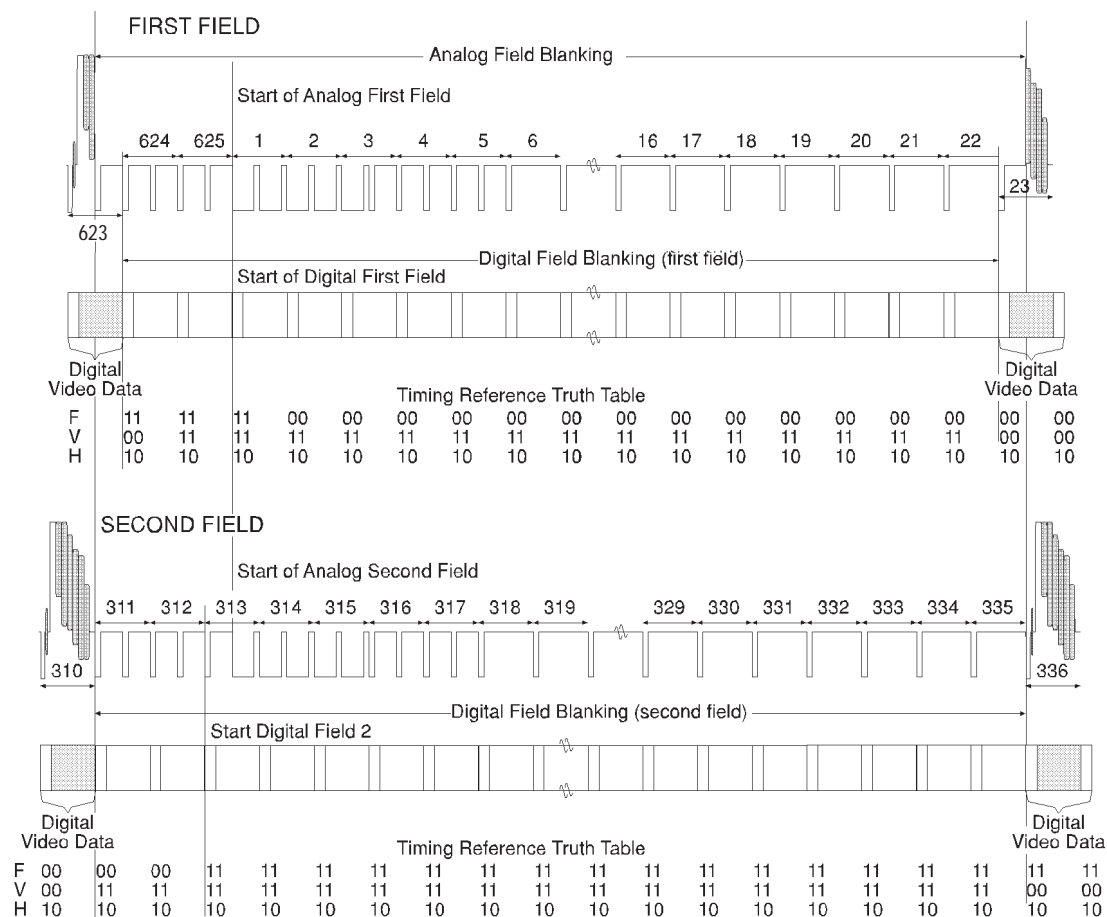

Figure 1-3: Relationship between digital and analog fields, showing also the position of the digital field-blanking interval in the 625 system

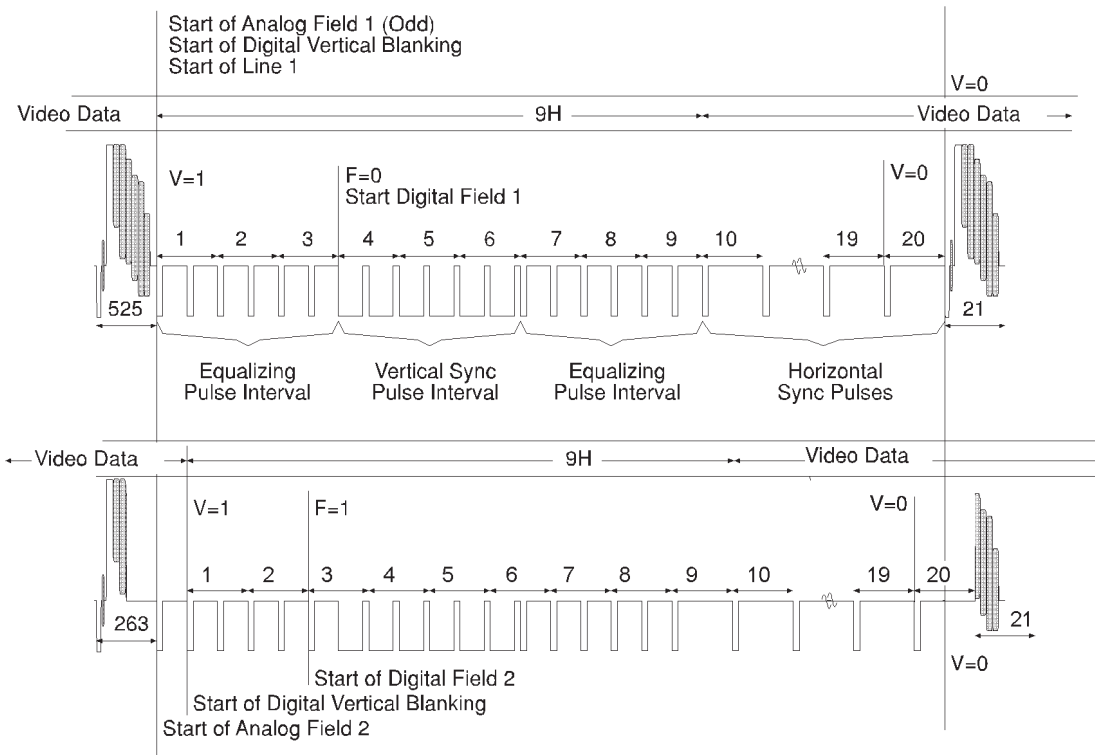

Figure 1-4: Relationship of video data/vertical sync, in 525 system

Table 1-3: Output characteristics for serial digital video signals

Characteristics	Performance requirements	Supplemental information
Standards Conformance		SMPTE 259M, EBU Tech 3267-E ITU-R BT.601 and ITU-R BT.656
Connector		BNC
Digital Format		Scrambled NRZI
Serial Bit Rate		270 Mbits/sec
Source Impedance		75 Ω
Return Loss		≥ 15 dB from 5 MHz to 270 MHz
Signal Amplitude	800 mV \pm 10%	75 Ω load impedance, with no transmission line
DC Offset	0 V \pm 0.5 V	
Rise and Fall Times	0.40 to 1.50 nsec	Measured between 20% and 80% amplitude points
Difference Between Rise and Fall Time	0.5 nsec	Measured between 20% and 80% amplitude points
Jitter		Less than \pm 0.25 nsec over a period of one video line
Required Receiver Termination		75 Ω , with return loss ≥ 15 dB from 5 MHz to 270 MHz

Table 1-4: Signal characteristics for analog black outputs (in base instrument only)

Characteristics	Performance requirements	Supplemental information
Standards Conformance		SMPTE 170M (NTSC), EBU N14-1988
Blanking Level	0 V \pm 100 mV	
Blanking Width (NTSC only)		10.7 μ sec \pm 0.2 μ sec
Black Level		
NTSC		0 or 7.5 IRE (user selectable)
PAL		Blanking Level
Sync Rise Time		
NTSC		140 nsec
PAL		250 nsec
Sync Amplitude		
NTSC	-40 IRE \pm 2 IRE	
PAL	-300 mV \pm 15 mV	
White Flag Level (PAL only)		0 or 700 mV (user selectable)

Table 1-4: Signal characteristics for analog black outputs (in base instrument only) (cont.)

Characteristics	Performance requirements	Supplemental information
Sync Timing		
NTSC		See Figures 1-5 and 1-6.
PAL		See Figure 1-7.
Burst Rise Time		
NTSC		400 nsec
PAL		350 nsec
Burst Amplitude		
NTSC	$40 \text{ IRE}_{p-p} \pm 2 \text{ IRE}$	
PAL	$300 \text{ mV}_{p-p} \pm 15 \text{ mV}$	
Burst Delay from Sync		
NTSC		19 cycles of subcarrier
PAL		25 cycles of subcarrier
Burst Duration		
NTSC		9 cycles of subcarrier
PAL		10 cycles of subcarrier
Burst Frequency		
NTSC		$3.579545 \text{ MHz} \pm 1 \text{ Hz}$
PAL		$4.43361875 \text{ MHz} \pm 1 \text{ Hz}$
SC/H Phase Accuracy	$0^\circ \pm 5^\circ$	
Field Timing Offset Range	± 2 fields	Relative to the genlock input
Field Timing Offset Resolution		Video field increments
Vertical Timing Offset Range	± 8 lines	Relative to the genlock input
Vertical Timing Offset Resolution		Video line increments
Horizontal Timing Offset Range	$\pm 1/2$ video line	Relative to the genlock input
Horizontal Timing Offset Resolution		$< 0.1^\circ$ of subcarrier
Horizontal Timing Offset Range	$\pm 1/2$ video line	Relative to the genlock input
Return Loss	$\geq 30 \text{ dB}$	0 – 5 MHz

Table 1-5: Signal characteristics for analog black outputs (in Option 1 only)

Characteristics	Performance requirements	Supplemental information
Standards Conformance		SMPTE 170M (NTSC), EBU N14-1988
Blanking Level	$0\text{ V} \pm 100\text{ mV}$	
Blanking Width (NTSC only)		$10.7\ \mu\text{sec} \pm 0.2\ \mu\text{sec}$
Black Level		
NTSC		0 or 7.5 IRE (user selectable)
PAL		Blanking Level
Sync Rise Time		
NTSC		140 nsec
PAL		250 nsec
Sync Amplitude		
NTSC	$-40\ \text{IRE} \pm 2\ \text{IRE}$	
PAL	$-300\ \text{mV} \pm 15\ \text{mV}$	
White Flag Level (PAL only)		0 or 700 mV (user selectable)
Sync Timing		
NTSC		See Figures 1-5 and 1-6.
PAL		See Figure 1-7.
Burst Rise Time		
NTSC		400 nsec
PAL		350 nsec
Burst Amplitude		
NTSC	$40\ \text{IRE}_{\text{p-p}} \pm 2\ \text{IRE}$	
PAL	$300\ \text{mV}_{\text{p-p}} \pm 15\ \text{mV}$	
Burst Delay from Sync		
NTSC		19 cycles of subcarrier
PAL		25 cycles of subcarrier
Burst Duration		
NTSC		9 cycles of subcarrier
PAL		10 cycles of subcarrier
Burst Frequency		
NTSC		$3.579545\ \text{MHz} \pm 1\ \text{Hz}$
PAL		$4.43361875\ \text{MHz} \pm 1\ \text{Hz}$
SC/H Phase Accuracy	$0^\circ \pm 5^\circ$	
Field Timing Offset Range	$\pm 2\ \text{fields}$	Relative to the genlock input
Field Timing Offset Resolution		Video field increments
Vertical Timing Offset Range	$\pm 8\ \text{lines}$	Relative to the genlock input

Table 1-5: Signal characteristics for analog black outputs (in Option 1 only) (cont.)

Characteristics	Performance requirements	Supplemental information
Vertical Timing Offset Resolution		Video line increments
Horizontal Timing Offset Range	$\pm 1/2$ video line	
Horizontal Timing Offset Resolution		Single 27 MHz clock cycles
Return Loss	≥ 30 dB	0 – 5 MHz

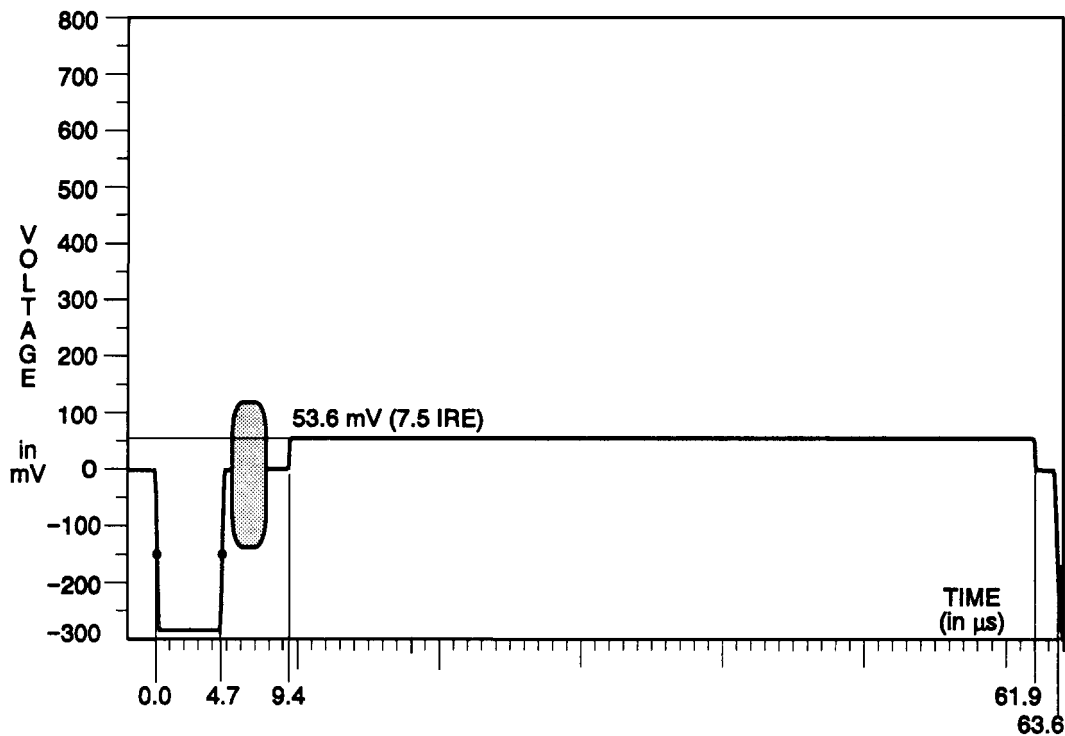

Figure 1-5: 60 Hz black burst with 7.5 IRE setup

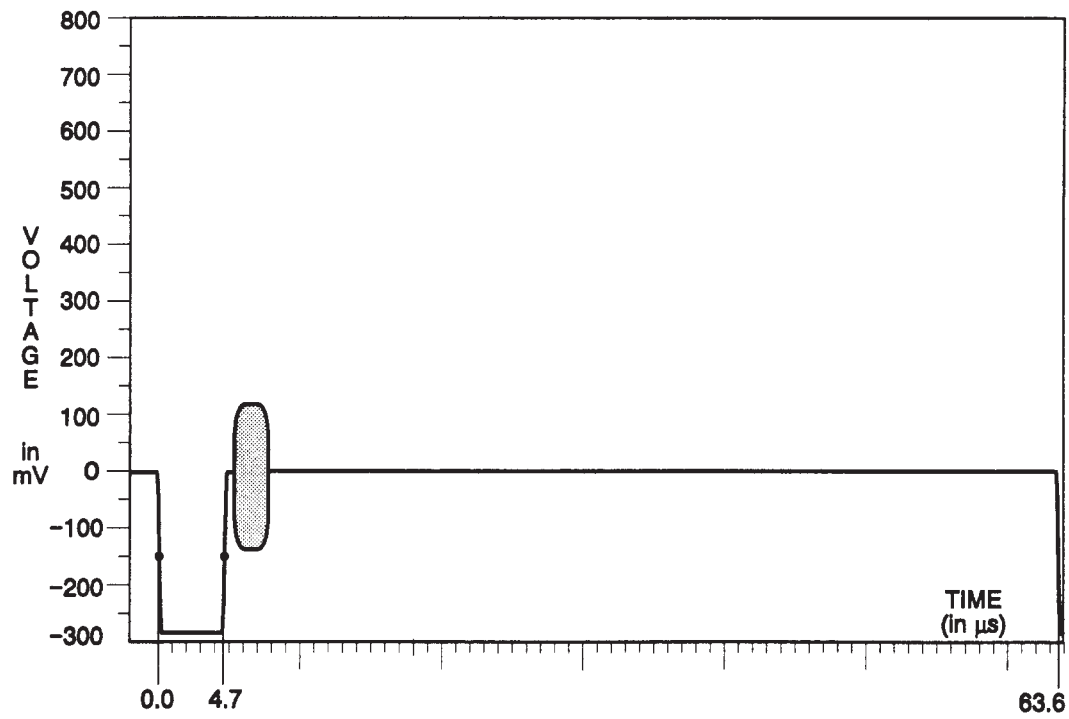

Figure 1-6: 60 Hz black burst with no setup

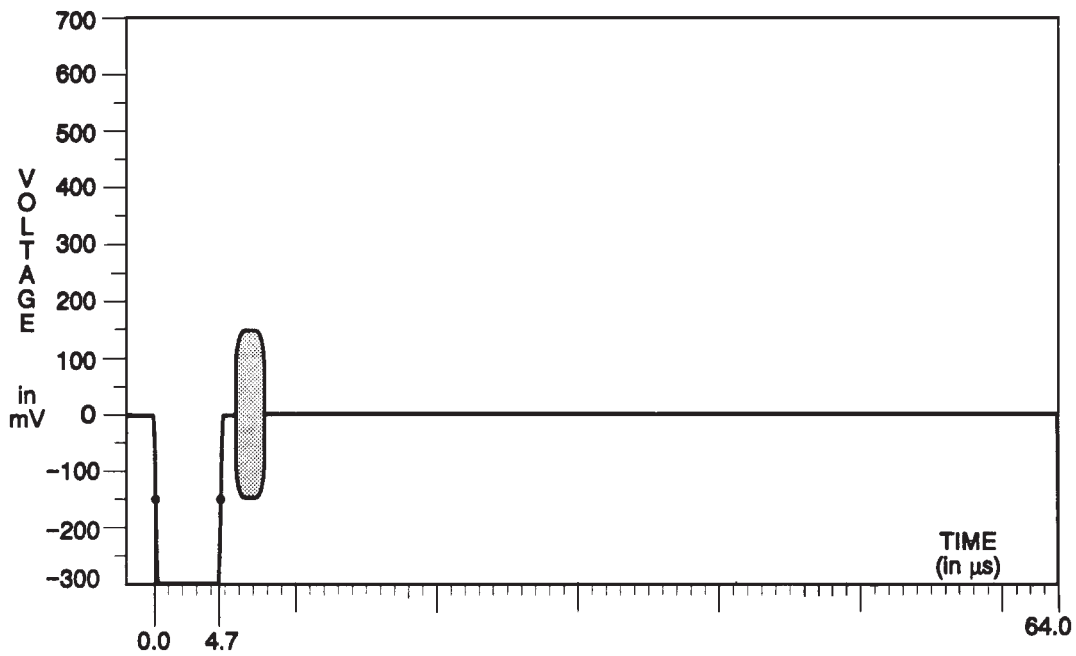

Figure 1-7: 50 Hz black burst

Table 1–6: Signal characteristics for serial bars output

Characteristics	Performance requirements	Supplemental information
Standards Conformance		SMPTE RP 165, SMPTE 259M
Serial Bars Output Signal	75% Bars	525 and 625 formats available. See Figures NO TAG, NO TAG, and 1–10. (50 Hz)
	SMPTE Bars	525/59.94 format only See Figures 1–17 through 1–25.
	75% Bars over Red Field Timing Color Bars Red	625/50 format only See Figures NO TAG, NO TAG, 1–10, 1–14, 1–15 and 1–16. Lines 23 – 166 Lines 167 – 310
	100% Bars over Red Field Timing Color Bars Red	625/50 format only See Figures 1–11, 1–12, 1–13, 1–14, 1–15 and 1–16. Lines 23 – 166 Lines 167 – 310
	100% Full-Field Bars	525 and 625 formats available. See Figures 1–11, 1–12, and 1–13.
	Serial Black	525 and 625 formats available.
Error Detection and Handling Insertion		Can be enabled or disabled by user
Field Timing Offset Range	± 1 field	Relative to the genlock input
Field Timing Offset Resolution		Video field increments
Vertical Timing Offset Range	± 8 lines	Relative to the genlock input
Vertical Timing Offset Resolution		Video line increments
Horizontal Timing Offset Range	± 1/2 video line	Relative to the Genlock input
Horizontal Timing Offset Resolution		Single 27 MHz clock-cycles

Table 1-7: Signal characteristics for serial test signal (Option 2 only)

Characteristics	Performance requirements	Supplemental information
Standards Conformance		SMPTE RP 165, SMPTE 259M
Serial Test Signals	75% Bars	See Figures NO TAG, NO TAG, and 1-10.
	100% Bars	See Figures 1-11, 1-12, and 1-13.
	Full-field Pluge	See Figures 1-47 (50 Hz) and 1-48 (60 Hz)
	Convergence	See Figures 1-32 & 1-33 (H), and 1-34 & 1-35 (V)
	Bowtie	See Figures 1-41, 1-42, and 1-43.
	Active Picture Markers	See Figures 1-36 and 1-37.
	Multiburst	See Figures 1-26 and 1-27.
	Pulse And Bar	See Figures 1-29 and 1-31.
	Ramp	See Figures 1-44, 1-45, and 1-46.
	Serial Digital Interface (SDI matrix)	<p>Matrix consists of Bit Slip and Clock Recovery Test signal and the Equalizer signal per SMPTE RP 178.</p> <p>Bit Slip stresses the recovery ability of the receiver clock regenerator by sending a string of twenty 0s followed by a single 1.</p> <p>The Equalizer Test signal contains a maximum low frequency content. It repeats a string of nineteen 0s followed by two 1s.</p>
EDH Insertion		Can be enabled or disabled by user.
Field Timing Offset Range	± 1 field	Relative to the genlock input
Field Timing Offset Resolution		Video field increments
Vertical Timing Offset Range	± 8 lines	Relative to the genlock input
Vertical Timing Offset Resolution		Video line increments

Table 1-8: Signal characteristics for AES/EBU serial digital audio outputs (XLR connectors)

Characteristics	Performance requirements	Supplemental information
Standards Conformance		ANSI S4.40, SMPTE RP 155-1990
Audio Connectors	2	3-pin XLRs, male contacts
Digital Format		Serial, balanced signal pair and a signal ground
Digital Code		Bi-phase mark
Output Level	2-7 V _{p-p}	Measured differentially across 110 Ω.
Required Receiver Termination	110 Ω ± 10%	
Encoding Format		Linear PCM, two's complement binary representation.
Audio Sampling Frequency		48.000 kHz, locked to video
Number of Audio Channels	4	2 AES/EBU audio pairs on each audio connector
Quantized Resolution		20 or 24 bits (user selectable)
Audio Tone Frequency	800 Hz or 1 kHz or Silence (audio black)	User selectable, channel-by-channel
Audio Tone Amplitude	-10 to -20 dB in 2 dB steps plus Silence (audio black)	User selectable, channel-by-channel
Rise and Fall Times	Between 5 and 30 nsec	Measure from the 10% to 90% points across 110 Ω.
Pre-emphasis		None
Jitter on Data transitions	Within ± 20 nsec from an ideal clock.	
Channel Status Bits		Uses default settings, except explicit data resolution status. Emphasis bits may be set to test receivers (but do not enable emphasis in the data). (See Table 4-15.)

Table 1-9: Signal characteristics for AES/EBU serial digital audio outputs (BNC outputs)

Characteristics	Performance requirements	Supplemental information
Standards Conformance		SMPTE RP 155-1990
Audio Connectors	2	BNC connectors
Audio Timing		
Digital Format		Serial, (unbalanced) signal and a signal ground
Digital Code		Bi-phase mark
Output Level	1 V ± 0.2 V	Measured across 75 Ω.
Required Receiver Termination	75 Ω ± 10%	

Table 1–9: Signal characteristics for AES/EBU serial digital audio outputs (BNC outputs) (cont.)

Characteristics	Performance requirements	Supplemental information
Encoding Format		Linear PCM, two's complement binary representation.
Audio Sampling Frequency		48.000 kHz, locked to video
Number of Audio Channels	4	2 AES/EBU audio pairs on each audio connector
Quantized Resolution		20 or 24 bits (user selectable)
Audio Tone Frequency	800 Hz or 1 kHz or Silence (audio black)	User selectable, channel-by-channel
Audio Tone Amplitude	–10 to –20 dBFS, in 2 dB steps plus Silence (audio black)	User selectable, channel-by-channel
Jitter on Data Transitions	Within ± 20 nsec from an ideal clock	
Pre-emphasis		None
Rise and Fall Times	Between 30 and 44 nsec	Measured from the 10% to 90% points across 75 Ω .
Channel Status Bits		Uses default settings, except explicit data resolution status. Emphasis bits may be set to test receivers (but do not enable emphasis in the data). (See Table 4-15.)

Table 1–10: Signal characteristics for embedded serial audio

Characteristics	Performance requirements	Supplemental information
Standards Conformance		SMPTE 259M, SMPTE 272M, and SMPTE 125M
Encoding Format		Linear PCM, two's complement binary representation
Audio Sampling Frequency		48.000 kHz, locked to video
Number of Audio Channels	4	
Quantized Resolution		20 bits
Audio Tone Frequency	800 Hz or 1 kHz or Silence (audio black)	User selectable, channel-by-channel
Audio Tone Amplitude	–10 to –20 dBFS, in 2 dB steps plus Silence (audio black)	User selectable, channel-by-channel
Pre-emphasis		None implemented in data.
Channel Status Bits		Uses default settings, except explicit data resolution status. Emphasis bits may be set to test receivers (but does not enable emphasis in the data). (See Table 4–15.)
20-bit Audio Sample Distribution		See Table 1–13. See Table 1–14.

Table 1-11: 20-bit audio signal sample distribution for embedded serial audio on 525/59.94 signals

Analog field 1 line numbers	Transmitted samples	Analog field 2 line numbers	Transmitted samples
5	4	268 (5)	4
10	0	273 (10)	0
11	0	274 (11)	0
12	0	275 (12)	0
13 ¹	3 / 4		
17	4	280 (17)	4
29	4	292 (29)	4
41	4	304 (41)	4
53	4	316 (53)	4
65	4	328 (65)	4
77	4	340 (77)	4
89	4	352 (89)	4
101	4	364 (101)	4
113	4	376 (113)	4
125	4	388 (125)	4
137	4	400 (137)	4
149	4	412 (149)	4
161	4	424 (161)	4
173	4	436 (173)	4
185	4	448 (185)	4
197	4	460 (197)	4
209	4	472 (209)	4
221	4	484 (221)	4
233	4	496 (233)	4
245	4	508 (245)	4
257	4	520 (257)	4
All Other Lines	3	All Other Lines	3

¹ Line 13 has 4 samples in Fields 1, 5, and 9.

Table 1-12: 20-bit audio signal sample distribution for embedded serial audio on 625/50 signals

Analog field 1 line numbers	Transmitted samples	Analog field 2 line numbers	Transmitted samples
5	4	318 (5)	4
6	0	319 (6)	0

Table 1-12: 20-bit audio signal sample distribution for embedded serial audio on 625/50 signals (cont.)

Analog field 1 line numbers	Transmitted samples	Analog field 2 line numbers	Transmitted samples
7	0	320 (7)	0
8	0	321 (8)	0
15	4	328 (15)	4
25	4	338 (25)	4
35	4	348 (35)	4
45	4	358 (45)	4
55	4	368 (55)	4
65	4	378 (65)	4
75	4	388 (75)	4
85	4	398 (85)	4
95	4	408 (95)	4
105	4	418 (105)	4
115	4	428 (115)	4
125	4	438 (125)	4
135	4	448 (135)	4
145	4	458 (145)	4
155	4	468 (155)	4
165	4	478 (165)	4
175	4	488 (175)	4
185	4	498 (185)	4
195	4	508 (195)	4
205	4	518 (205)	4
215	4	528 (215)	4
225	4	538 (225)	4
235	4	548 (235)	4
245	4	558 (245)	4
255	4	568 (255)	4
265	4	578 (265)	4
275	4	588 (275)	4
285	4	598 (285)	4
295	4	608 (295)	4
305	4	618 (305)	4
314	4		
All Other Lines	3	All Other Lines	3

Table 1-13: Audio channel status bits (serial and embedded audio data streams)

Byte	Bit	Value	Function
0	0	1	Professional use of channel status
	1	0	Normal audio mode
	2-4	100 (default)	No emphasis
		110 (selectable)	50/15 sec emphasis
		111 (selectable)	CCITT J17 emphasis
	5	0	Source sampling frequency locked
6-7	01	48 kHz sampling frequency	
1	0-3	0001	Two-channel mode
	4-7	0001	192-bit block structure, preamble Z indicates start of block
2	0-2	000 (selectable)	Maximum 20-bit audio sample data
		001 (selectable)	Maximum 24-bit audio sample data (not available for embedded)
	3-5	101	Word length specified in bits 0-2
	6-7	00	Reserved
3	0-7	0000 0000	Reserved
4	0-7	0000 0000	Reserved
5	0-7	0000 0000	Reserved
6	0-7	0000 0001	Alphanumeric Channel – Origin
7	0-7	0000 0001	Alphanumeric Channel – Origin
8	0-7	0000 0001	Alphanumeric Channel – Origin
9	0-7	0000 0001	Alphanumeric Channel – Origin
10	0-7	0000 0001	Alphanumeric Channel – Destination
11	0-7	0000 0001	Alphanumeric Channel – Destination
12	0-7	0000 0001	Alphanumeric Channel – Destination
13	0-7	0000 0001	Alphanumeric Channel – Destination
14	0-7	0000 0000	Local Sample Address Code
15	0-7	0000 0000	Local Sample Address Code
16	0-7	0000 0000	Local Sample Address Code
17	0-7	0000 0000	Local Sample Address Code
18	0-7	0000 0000	Time Sample Address Code
19	0-7	0000 0000	Time Sample Address Code
20	0-7	0000 0000	Time Sample Address Code
21	0-7	0000 0000	Time Sample Address Code
22	0-3	0000	Reserved
	4-7	0000	Bytes 0-21 are reliable
23	0-7	(Depends on user choices shown above)	Channel status cyclic redundancy check character (over bytes 0-22) 0FX0, 0X55

Table 1–14: Genlock function

Characteristics	Performance requirements	Supplemental information
Input Configuration	One 75 Ω loopthrough or two 75 Ω terminating inputs	User selectable
Genlock Input Return Loss	≥ 40 dB	0 – 5 MHz
Isolation between two 75 Ω terminating inputs	≥ 60 dB	0 – 5 MHz
Internal Reference Free-Run Frequency	13.5 MHz \pm 13 Hz	1 ppm/year max drift combined with 1 year calibration cycle.
Pull-in Range	Subcarrier frequency \pm 20 Hz	
Genlock Input Signals		Burst locks to NTSC and PAL composite signals. Sync locks to monochrome NTSC and PAL signals. Carrier locks to 1, 3.58, 4.43, 5, and 10 MHz.
Carrier Lock Amplitude		2 V_{p-p} (8 dBm) nominal input level
Burst Lock Jitter	$\leq 0.5^\circ$	SNR ² >50 dB.
Genlock Noise Performance		Will remain locked with SNR > 30 dB or 60 Hz hum < 1 V_{p-p} .
Burst Lock Phase Change with Input Burst Amplitude	$\leq 1^\circ$	Over burst amplitude range of nominal value \pm 3 dB.
Burst Lock Phase Change with Input Signal APL	$\leq 1^\circ$	Over input signal APL range of 10% to 90%.
Sync Lock Jitter	≤ 0.6 nsec	($\approx 0.75^\circ$ at 3.58 MHz, $\approx 1^\circ$ at 4.43 MHz), SNR >50 dB
Sync Lock Timing Change with Input Sync Amplitude	≤ 2 nsec	Over sync amplitude range of nominal value +3 to –3 dB.
Input SC/H Phase Range for Correct Color Framing	$0^\circ \pm 45^\circ$	Will maintain initial color framing until the SC/H error exceeds 120 $^\circ$ nominally.
Genlock Timing Range	± 2 fields ± 8 lines $\pm 1/2$ line sub-clock-cycles	
Genlock Timing Resolution		< 0.1 $^\circ$ of subcarrier.

² SNR is defined as the ratio of 1 V_{p-p} video to the rms value of white gaussian noise over a 5 MHz bandwidth.

Table 1-15: Power Supply

Characteristics	Performance requirements	Supplemental information
Supply Accuracy		
+12 V		+12 V ± 300 mV
+5 V		+5 V ± 100 mV
-5 V		-5.5 V ± 500 mV
-12 V		-12 V ± 300 mV
Current Limit		Total power limited to ≈120 W.
+12 V		
+5 V		
-5 V		
-12 V		
Hum		Typical values:
+12 V		10 mV
+5 V		10 mV
-5 V		20 mV
-12 V		10 mV
Noise		(5 MHz measurement bandwidth)
+12 V		≤50 mV
+5 V		≤50 mV
-5 V		≤50 mV
-12 V		≤50 mV
Line Voltage Range	85 – 132 VAC 180 – 250 VAC	Supply set for 110 V operation Supply set for 220 V operation
Crest Factor		≥1.35
Fuse Required		2 A med. blow (110 V operation) 1 A med. blow (220 V operation)
Power Consumption		60 W maximum
Power Line Frequency		48 to 62 Hz

Table 1–16: Mechanical (physical) characteristics

Characteristics	Supplemental information
Rackmount Dimensions	
Height	1.734 inches (4.4 cm)
Width	19.0 inches (48.3 cm)
Length	22.1 inches (56.1 cm)
Net Weight	13.5 lbs. (6.14 kg)
Shipping Weight	22 lbs., 14 oz. (10.4 kg)

Table 1–17: Environmental characteristics

Characteristics	Supplemental information
Temperature	
Non-operating	–40° C to +65° C
Operating	0° C to +50° C IEC 1010–1 compliance to +40° C.
Altitude	
Non-operating	To 50,000 feet
Operating	To 15,000 feet (4572) Meters IEC 1010-1 compliance to 2000 Meters.
Humidity	5 – 95% humidity, non-condensing
Vibration	
Operating	From 5 to 350 Hz: 0.0002 g ² /Hz Acceleration Power Spectral Density (APSD) From 350 to 500 Hz: –3 dB/Octave Slope At 500 Hz: 0.00014 g ² /Hz APSD 0.31 GRMS Overall 10 Minutes/Axis
Non-operating	From 5 to 100 Hz: 0.020 g ² /Hz (APSD) From 100 to 200 Hz: –3 dB/Octave Slope From 200 to 350 Hz: 0.010 g ² /Hz APSD From 350 to 500 Hz: –3 dB/Octave Slope At 500 Hz: 0.007 g ² /Hz APSD 2.46 overall GRMS 10 minutes/axis
Shock	
Non-operating	Half Sine Wave Shock Levels: 50 g's (instrument), 11 msec duration, 3 shocks per direction.

Table 1-17: Environmental characteristics (cont.)

Characteristics	Supplemental information
Transportation	Qualified under NTSC Test Procedure 1A, Category II (24-inch drop)
Vehicle Vibration (Random Vibration)	Vibrate along all three axes at an overall vibration level of 1.33 GRMS. One hour per axis.
Second Manual Handling (Shock)	Drop on all sides once from a height of 24 inches. Drop on the bottom from a height of 48 inches.
Equipment Type	Test
Equipment Class	Class I (grounded product) (as defined in IEC 1010-1, Annex H)
Installation Category	Installation Category II (as defined in IEC 1010-1, Annex J) Rated for indoor use only.
Pollution Degree	Pollution Degree 2 (as defined in IEC 1010-1)

Table 1-18: Certifications and compliances

EC Declaration of Conformity – EMC	<p>Meets intent of Directive 89/336/EEC for Electromagnetic Compatibility. Compliance was demonstrated to the following specifications as listed in the Official Journal of the European Communities:</p> <p>EN 50081-1 Emissions: EN 55022 Class B Radiated and Conducted Emissions EN 60555-2 AC Power Line Harmonic Emissions</p> <p>EN 50082-1 Immunity: IEC 801-2 Electrostatic Discharge Immunity IEC 801-3 RF Electromagnetic Field Immunity IEC 801-4 Electrical Fast Transient/Burst Immunity IEC 801-5 Power Line Surge Immunity</p> <p>¹ High-quality shielded cables must be used to ensure compliance with the above listed standards.</p>
EMC Compliance	Meets the intent of Directive 89/336/EEC for Electromagnetic Compatibility when it is used with the product(s) stated in the specifications table. Refer to the EMC specification published for the stated products. May not meet the intent of the Directive if used with other products.
FCC Compliance	Emissions comply with FCC Code of Federal Regulations 47, Part 15, Subpart B, Class A Limits
EC Declaration of Conformity – Low Voltage	<p>Compliance was demonstrated to the following specification as listed in the Official Journal of the European Communities:</p> <p>Low Voltage Directive 73/23/EEC EN 61010-1:1993 Safety requirements for electrical equipment for measurement, control, and laboratory use</p>

Table 1-18: Certifications and compliances (cont.)

Approvals	UL3111-1 – Standard for electrical measuring and test equipment CAN/CSA C22.2 No. 1010.1 – Safety requirements for electrical equipment for measurement, control and laboratory use
Installation Category Descriptions	Terminals on this product may have different installation category designations. The installation categories are: CAT III Distribution-level mains (usually permanently connected). Equipment at this level is typically in a fixed industrial location CAT II Local-level mains (wall sockets). Equipment at this level includes appliances, portable tools, and similar products. Equipment is usually cord-connected CAT I Secondary (signal level) or battery operated circuits of electronic equipment

Signal Illustrations

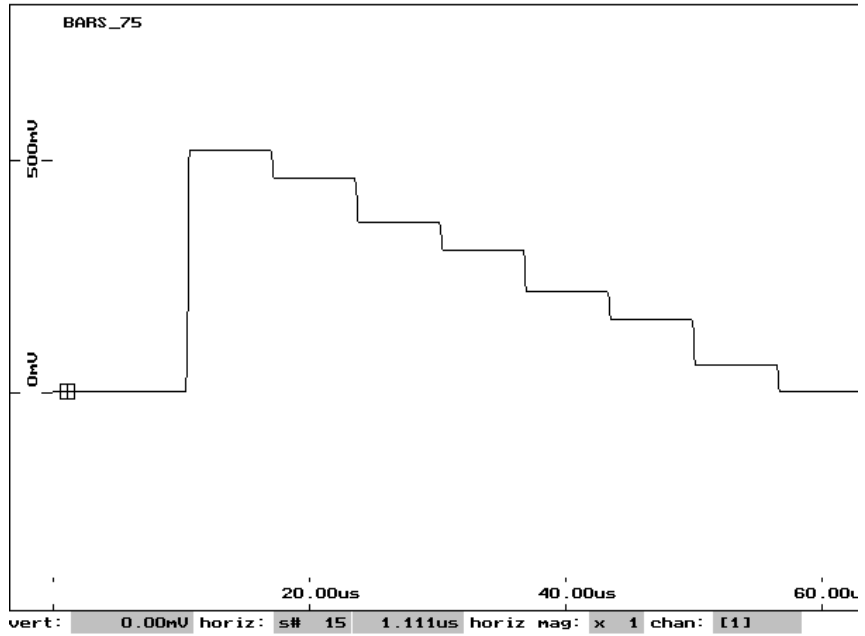

Figure 1-8: 75% Color bars — Y channel

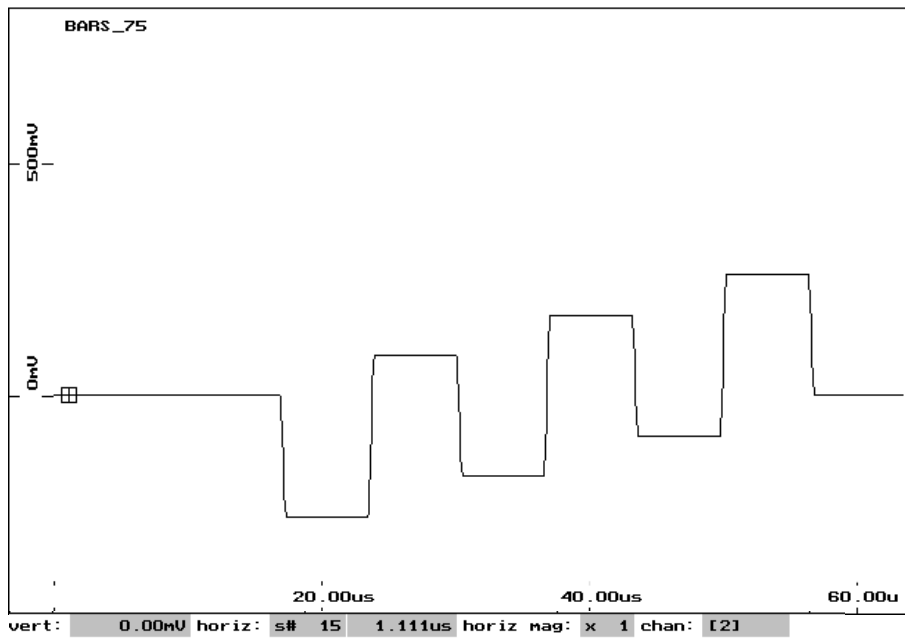

Figure 1-9: 75% Color bars — C_B channel

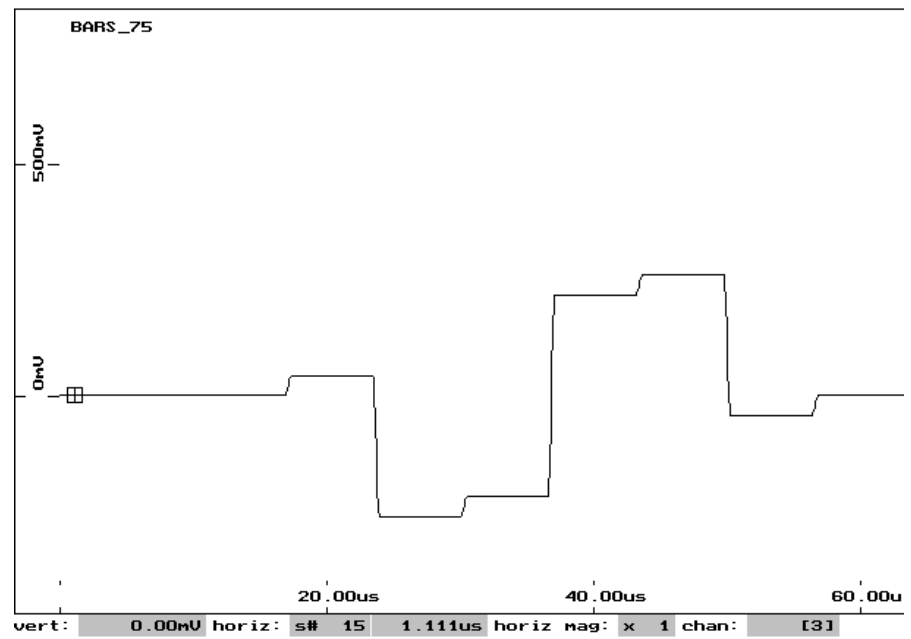

Figure 1-10: 75% Color bars — C_R channel

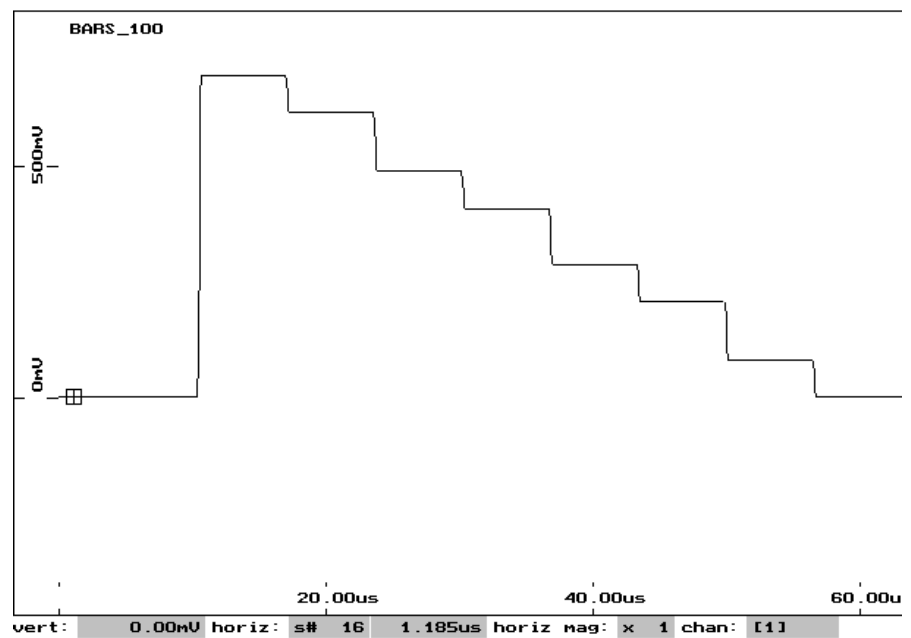

Figure 1-11: 100% Color bars — Y channel

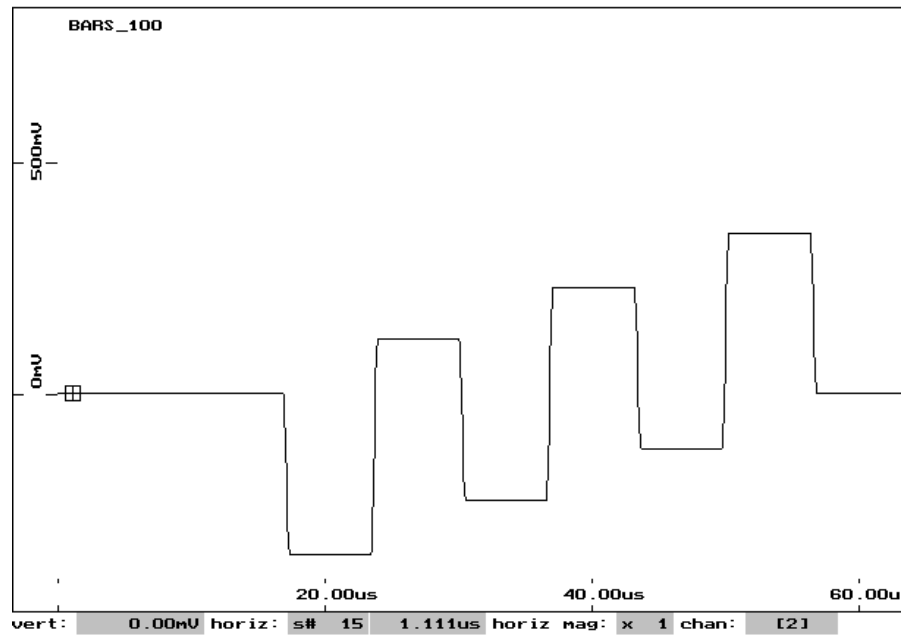

Figure 1-12: 100% Color bars — C_B channel

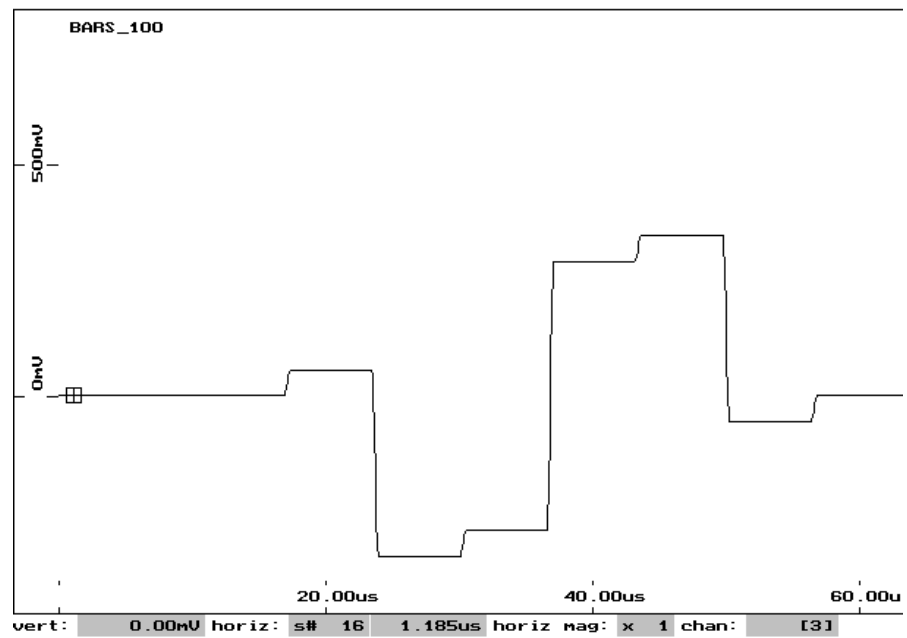

Figure 1-13: 100% Color bars — C_R channel

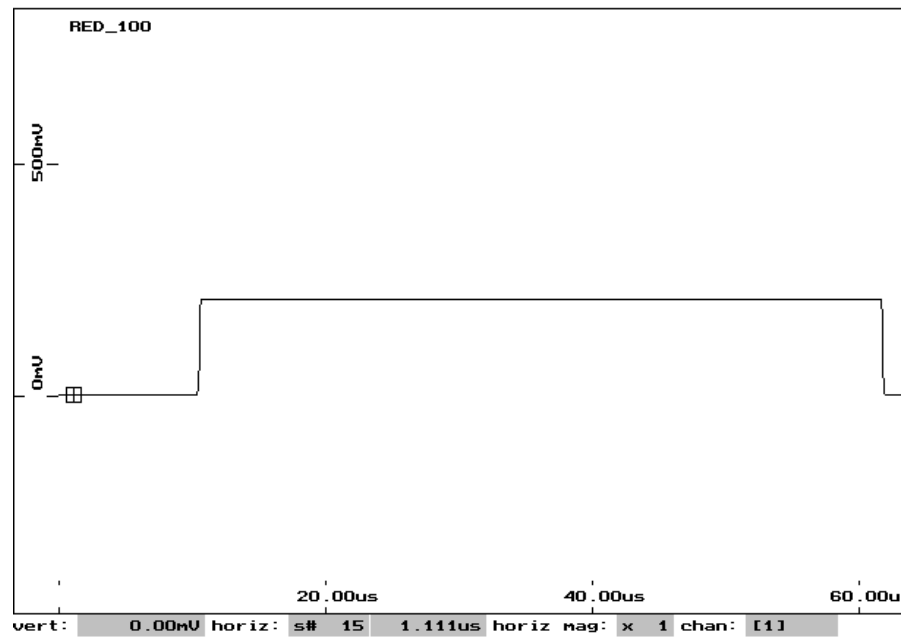

Figure 1-14: 100% Red — Y channel

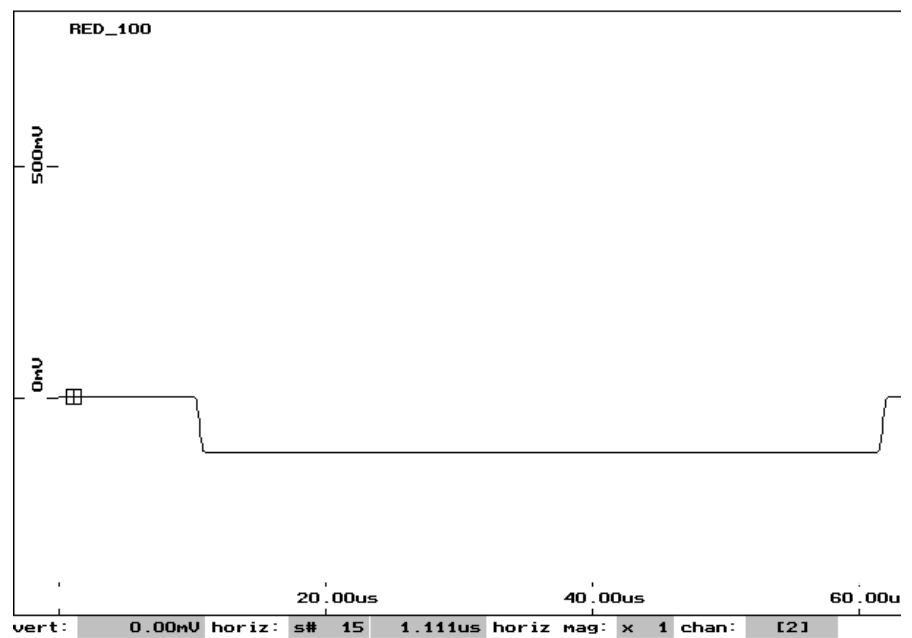

Figure 1-15: 100% Red — C_B channel

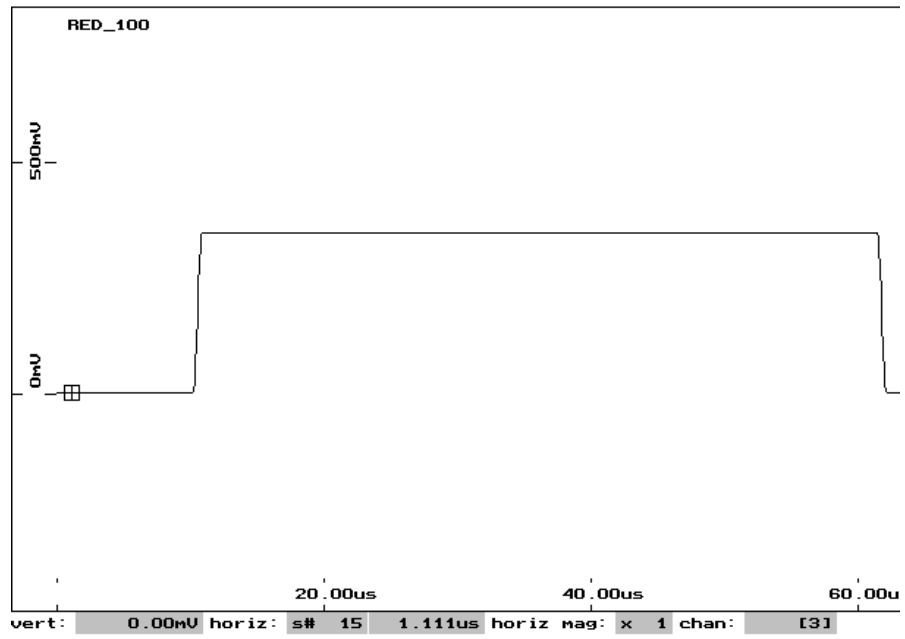

Figure 1-16: 100% Red — C_R channel

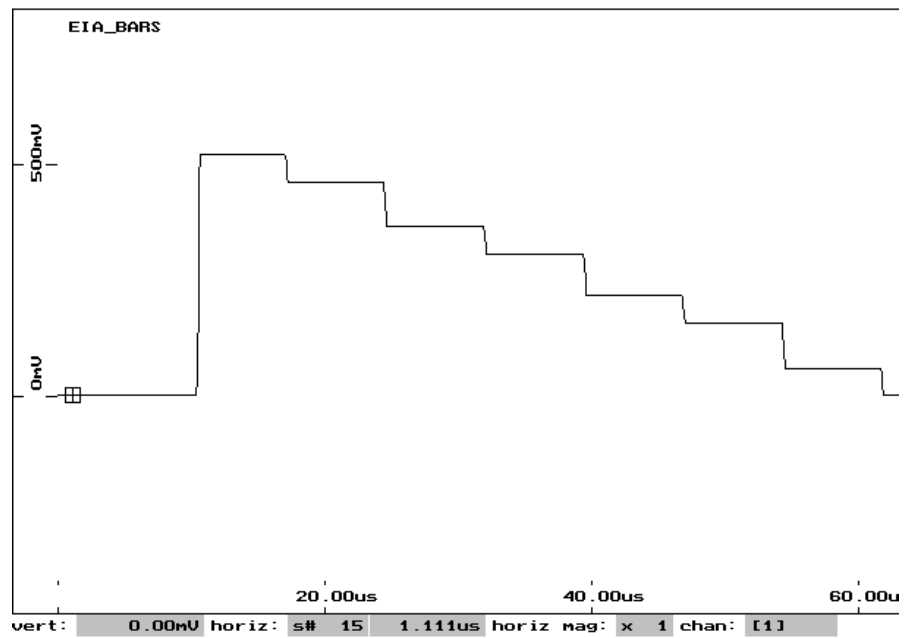

Figure 1-17: EIA bars (part of SMPTE bars) — Y channel

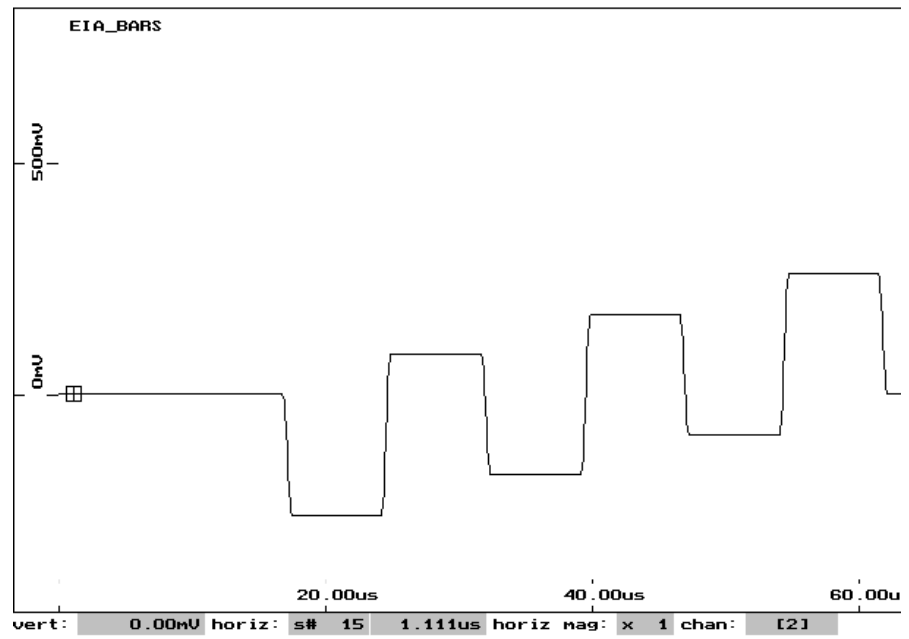

Figure 1-18: EIA bars (part of SMPTE bars) — C_B channel

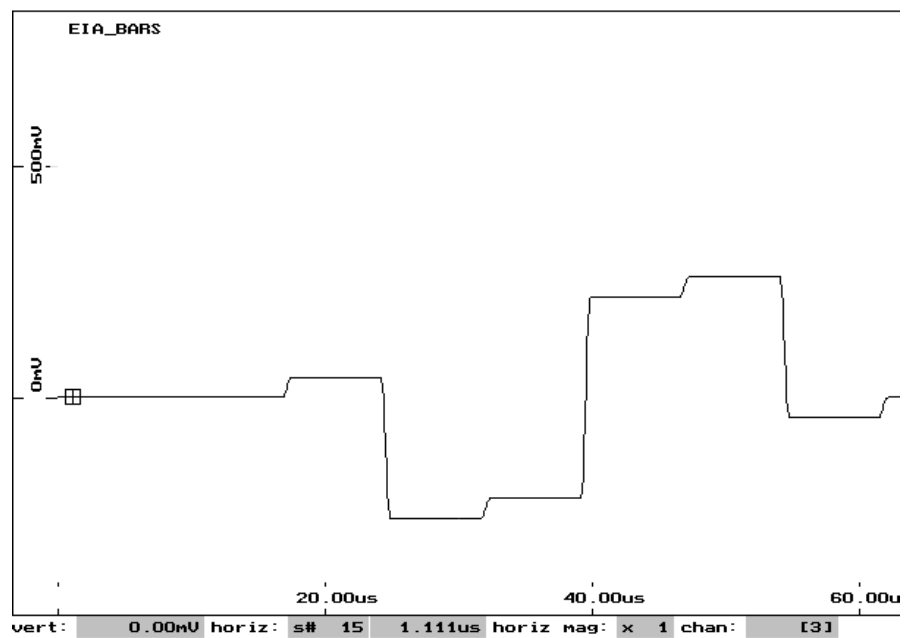

Figure 1-19: EIA bars (part of SMPTE bars) — C_R channel

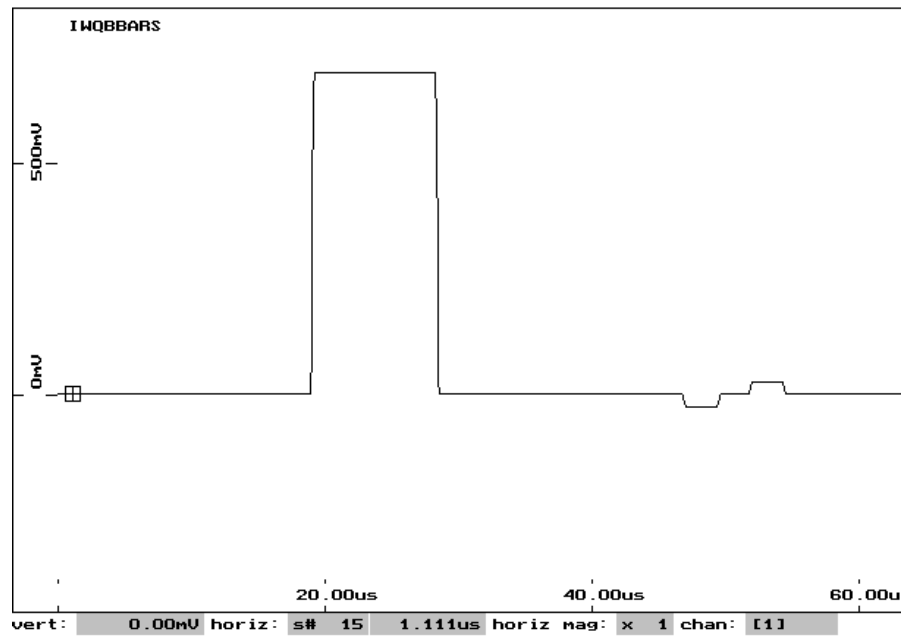

Figure 1-20: IWO bars (part of SMPTE bars) — Y channel

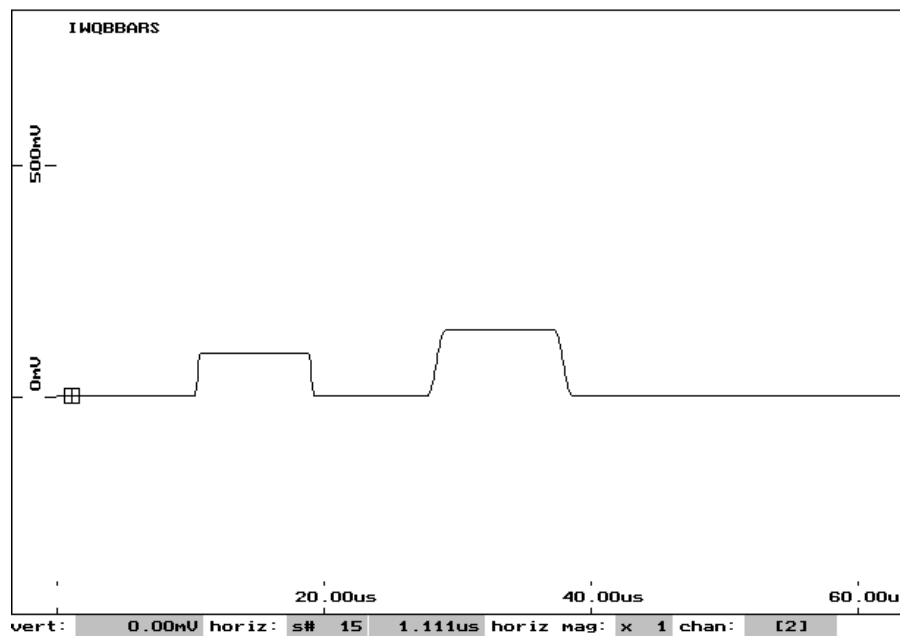

Figure 1-21: IWO bars (part of SMPTE bars) — C_B channel

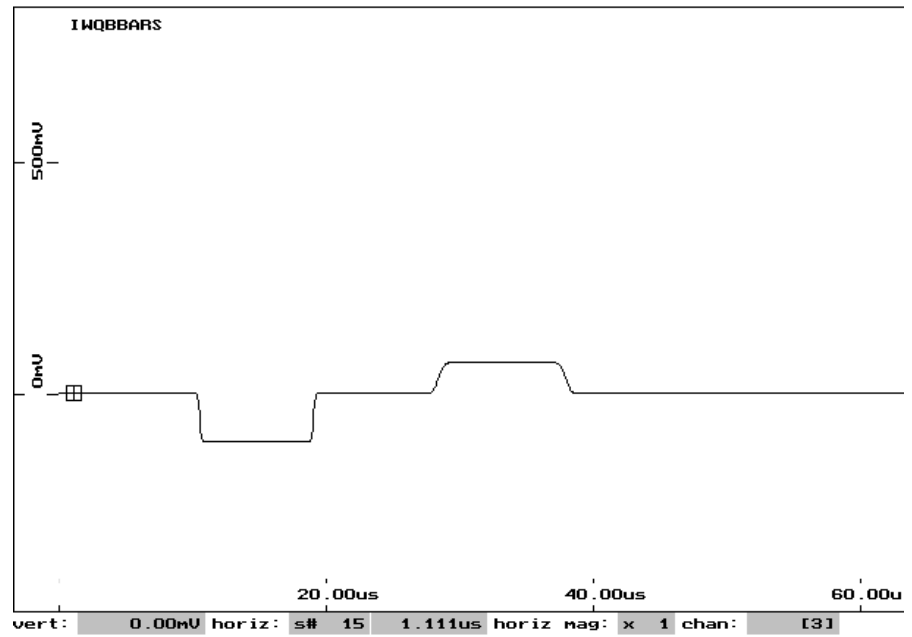

Figure 1-22: IWQ bars (part of SMPTE bars) — C_R channel

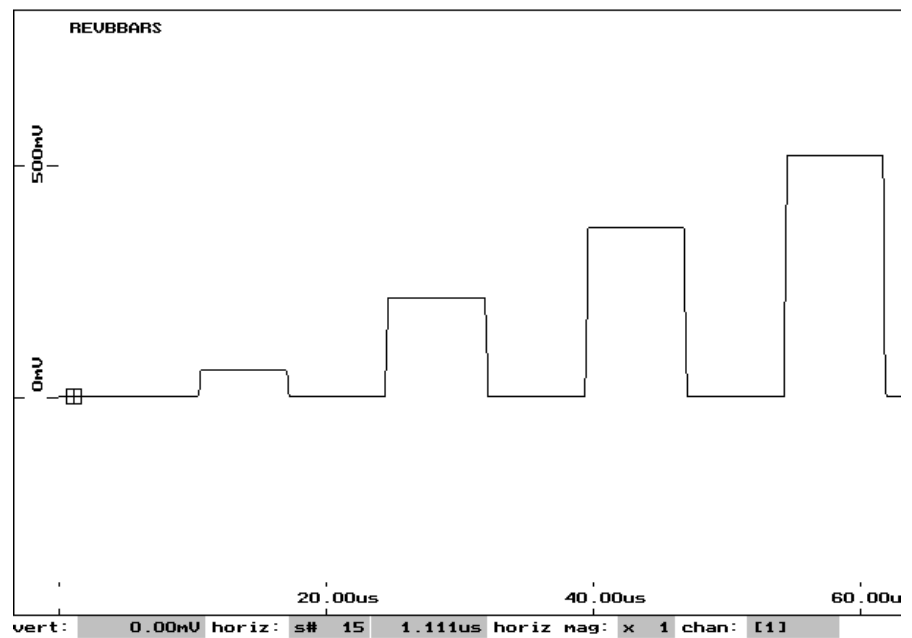

Figure 1-23: Reverse bars (part of SMPTE bars) — Y channel

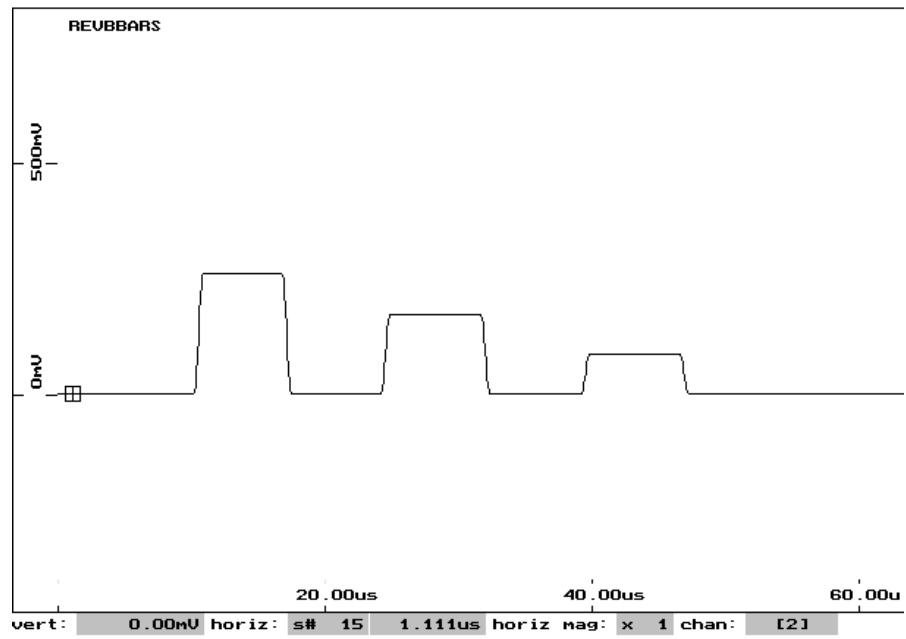

Figure 1-24: Reverse bars (part of SMPTE bars) — C_B channel

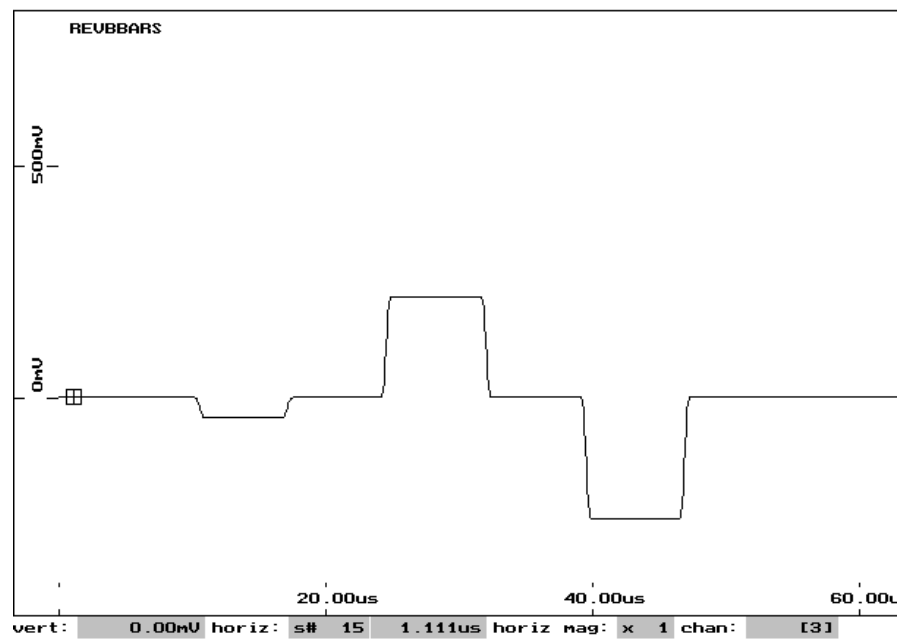

Figure 1-25: Reverse bars (part of SMPTE bars) — C_R channel

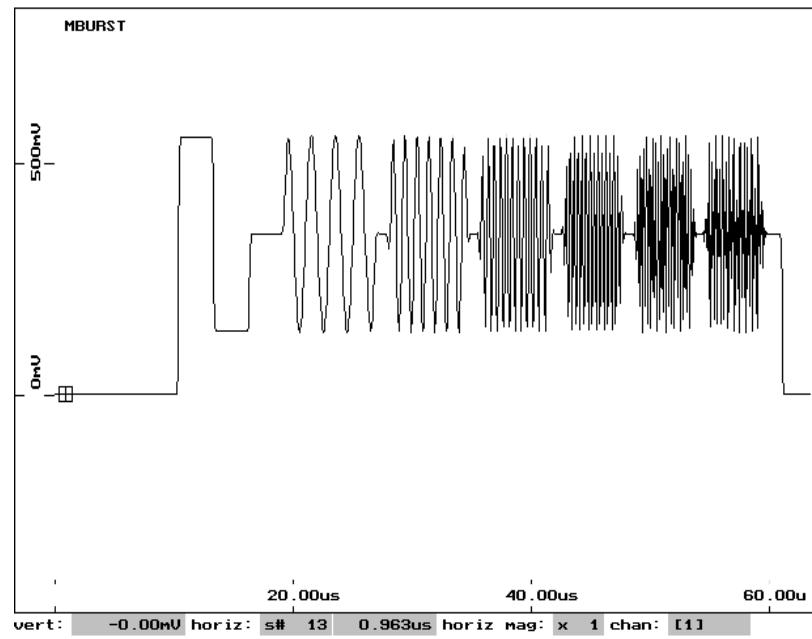

Figure 1-26: Multiburst — Y channel

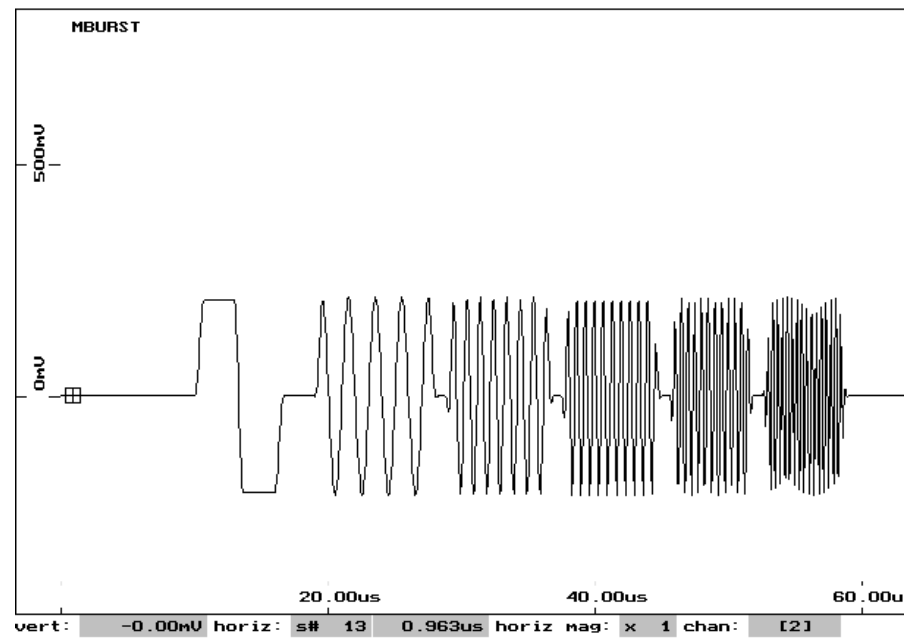

Figure 1-27: Multiburst for C_B

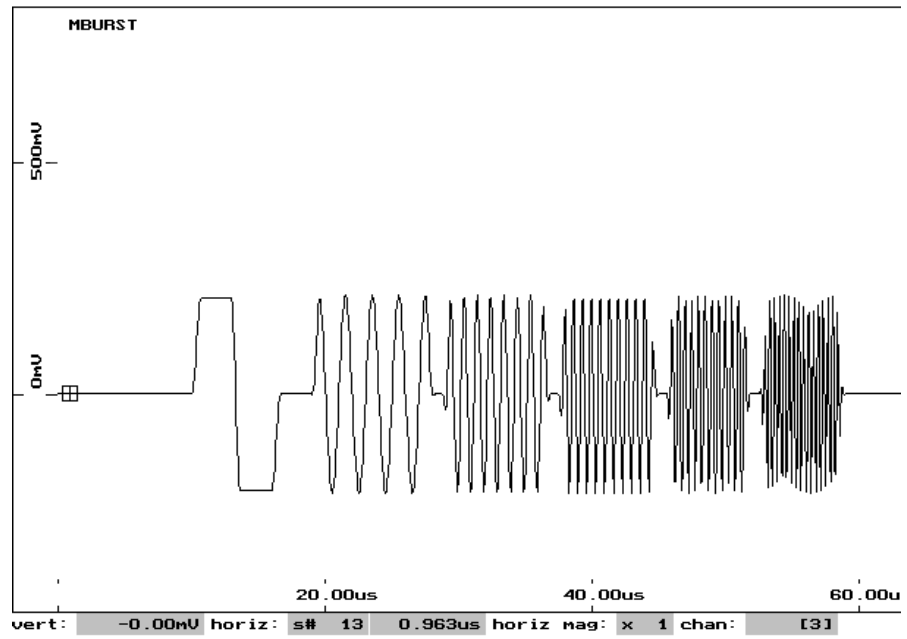

Figure 1-28: Multiburst for C_B and C_R

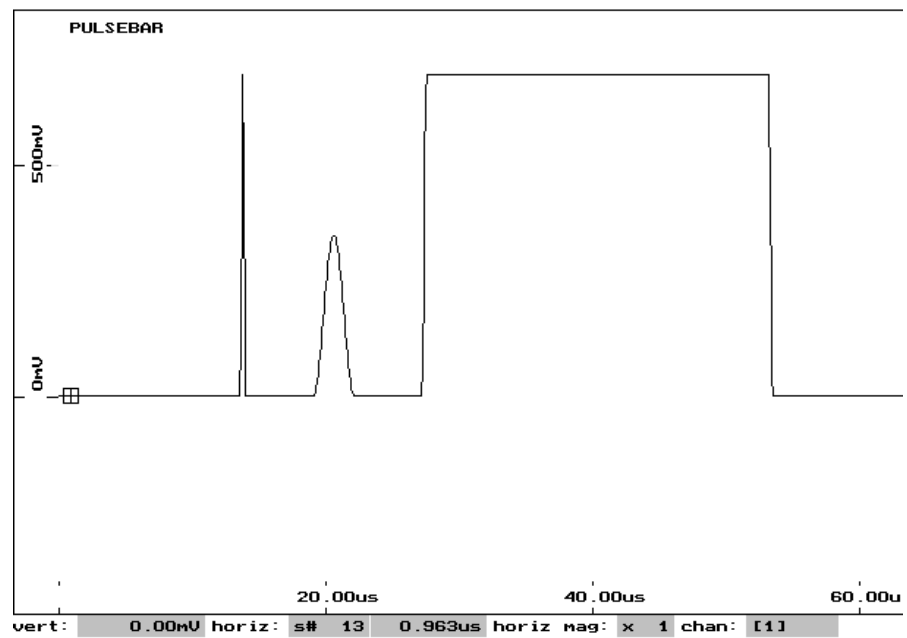

Figure 1-29: Modulated pulse and bar — Y channel

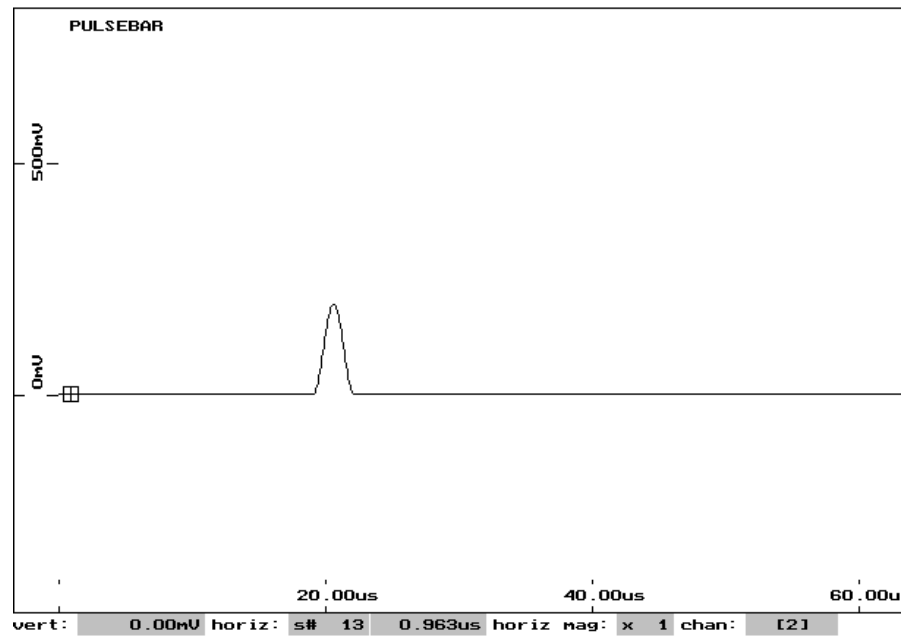

Figure 1-30: Modulated pulse and bar for C_B

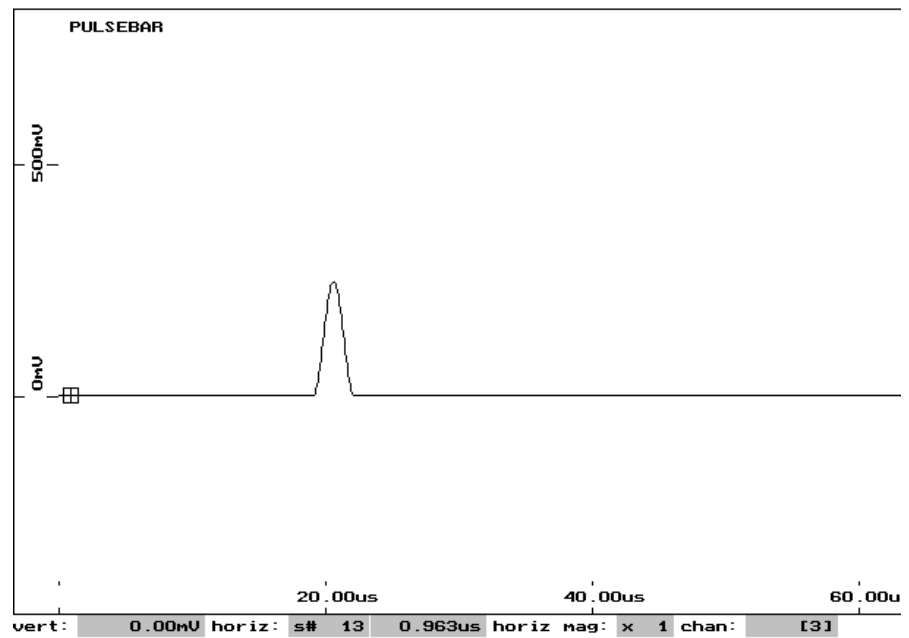

Figure 1-31: Modulated pulse and bar for C_R

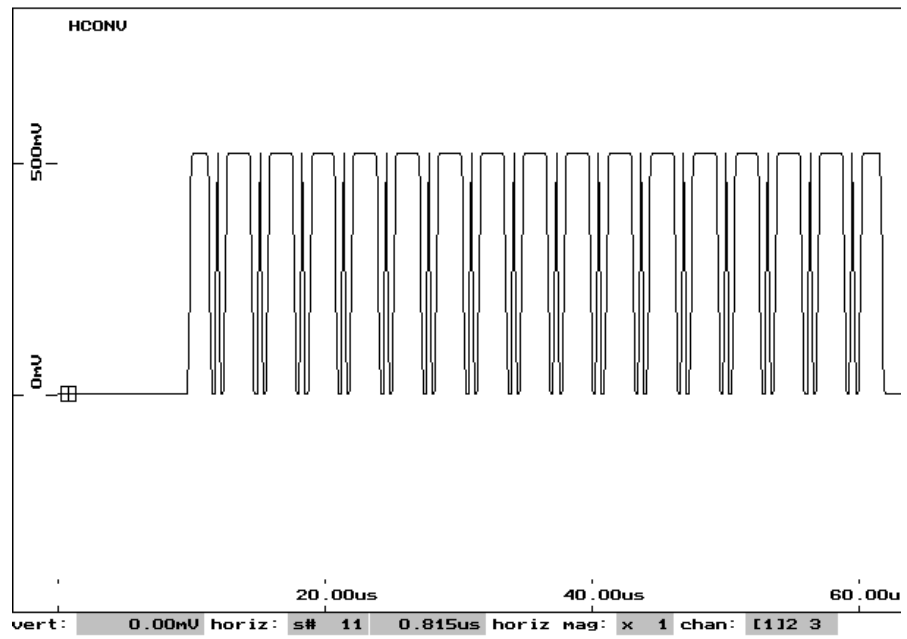

Figure 1-32: Convergence (horizontal) — Y channel

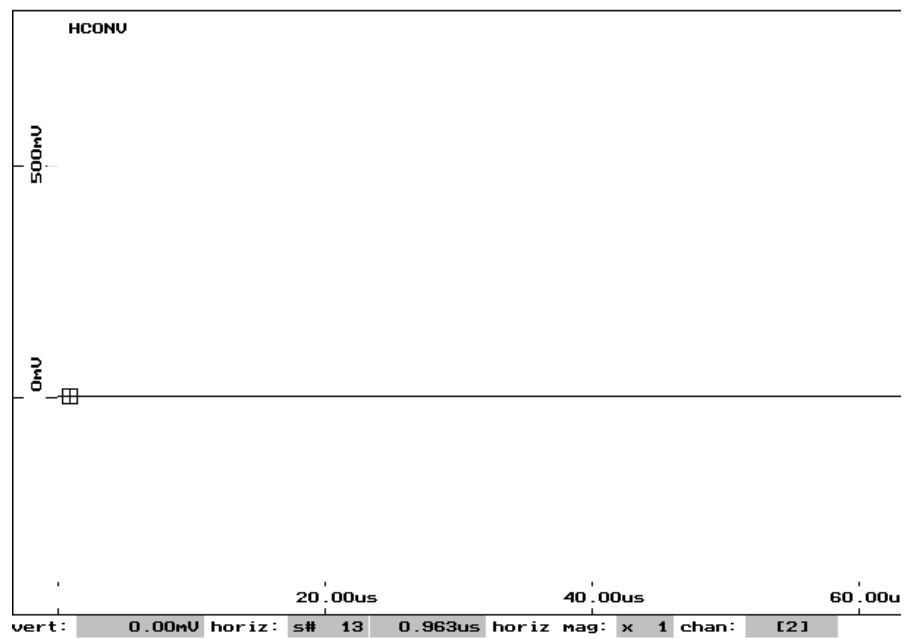

Figure 1-33: Convergence (horizontal) — C_B and C_R channels

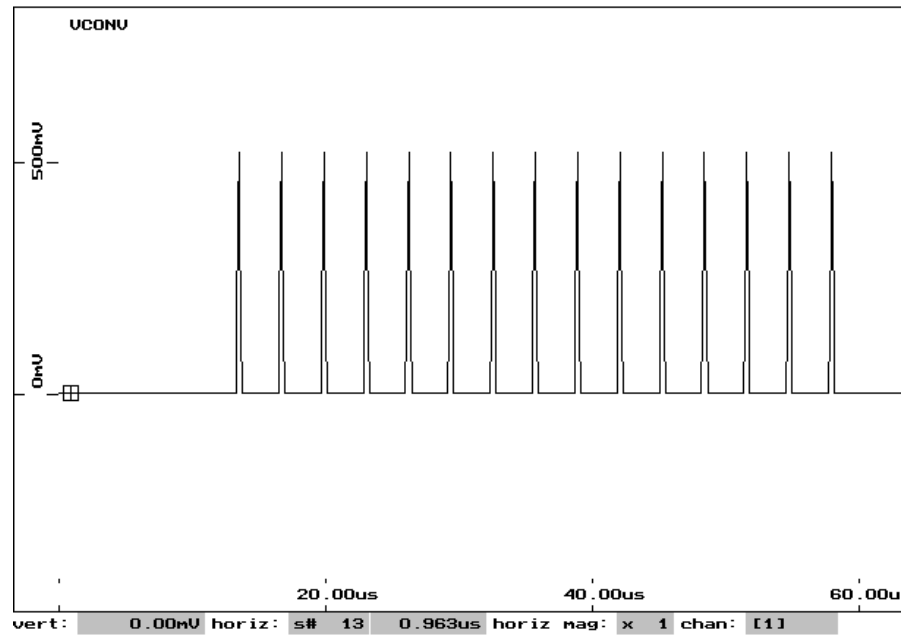

Figure 1-34: Convergence (vertical) — Y channel

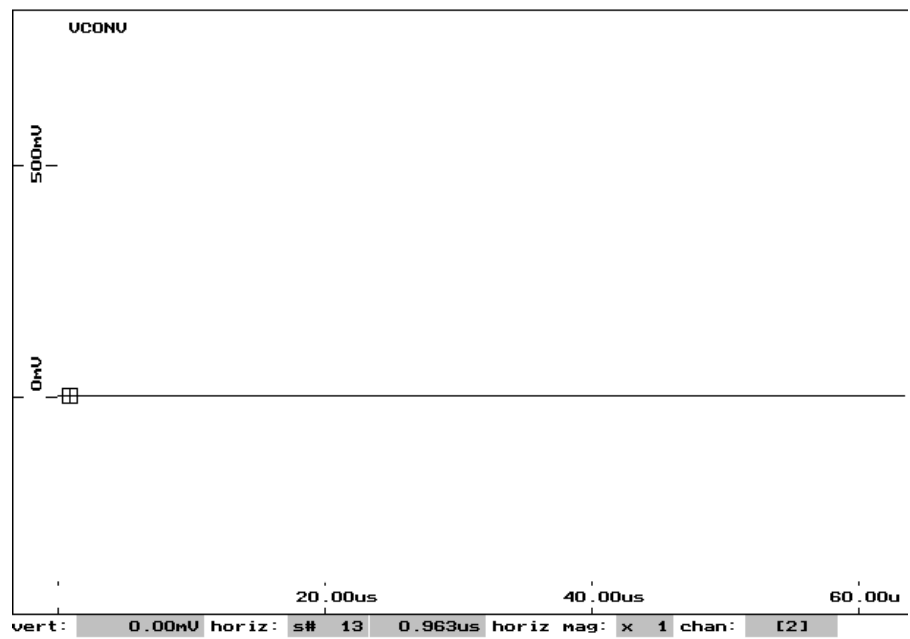

Figure 1-35: Convergence (vertical) — C_B and C_R channels

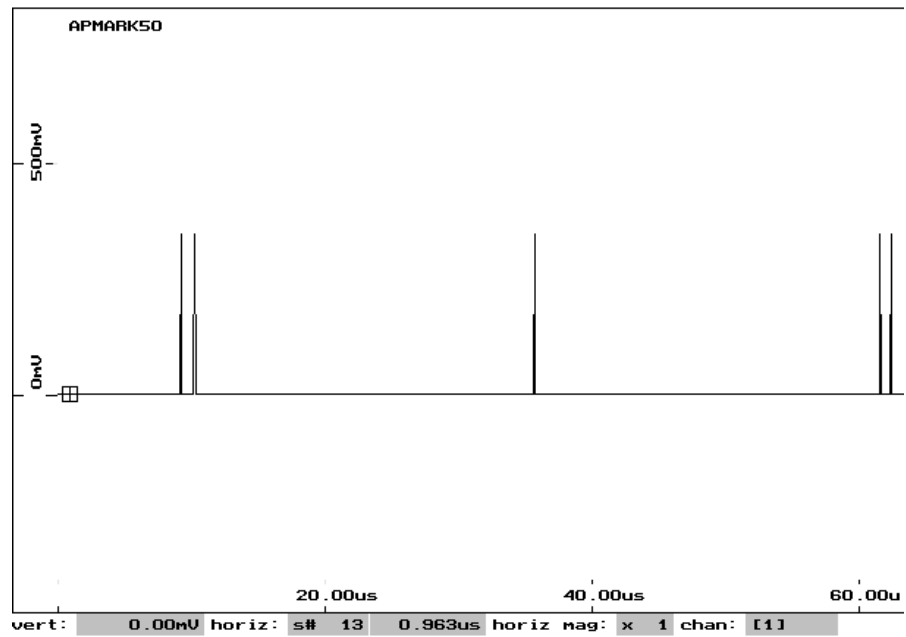

Figure 1-36: Active picture markers (part of active picture timing test signal) — Y channel

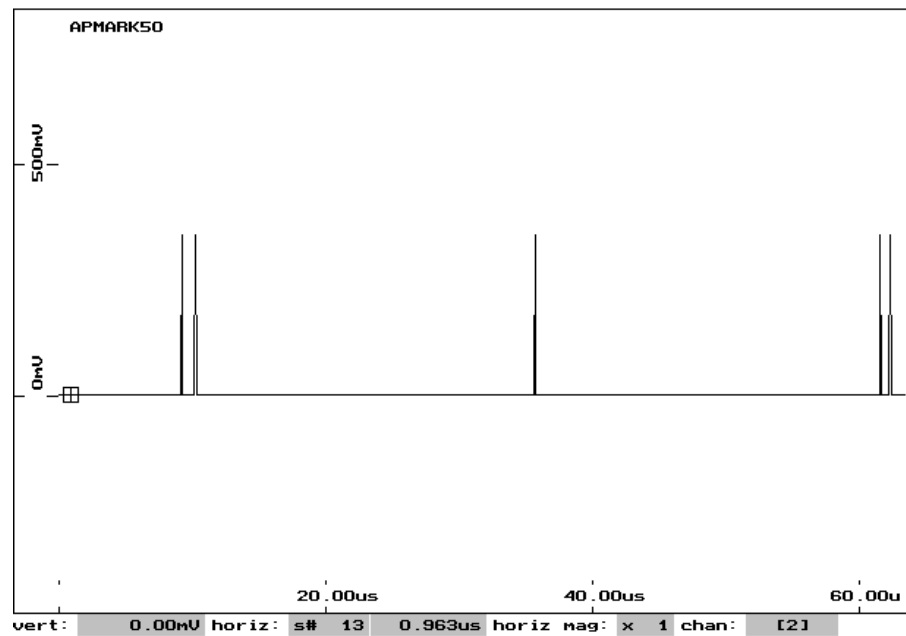

Figure 1-37: Active picture markers (part of active picture timing test signal) — C_B

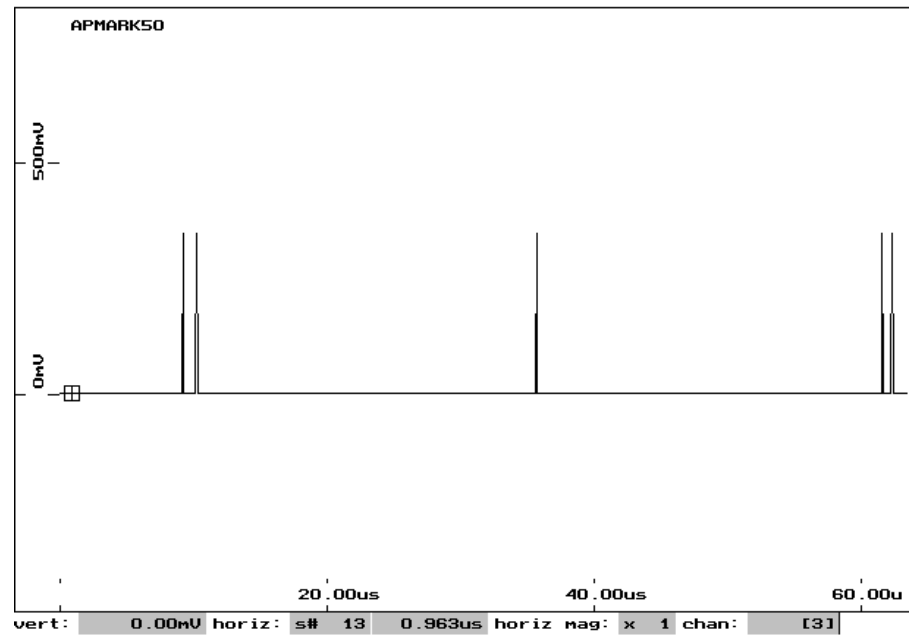

Figure 1-38: Active picture markers (part of active picture timing test signal) — C_R

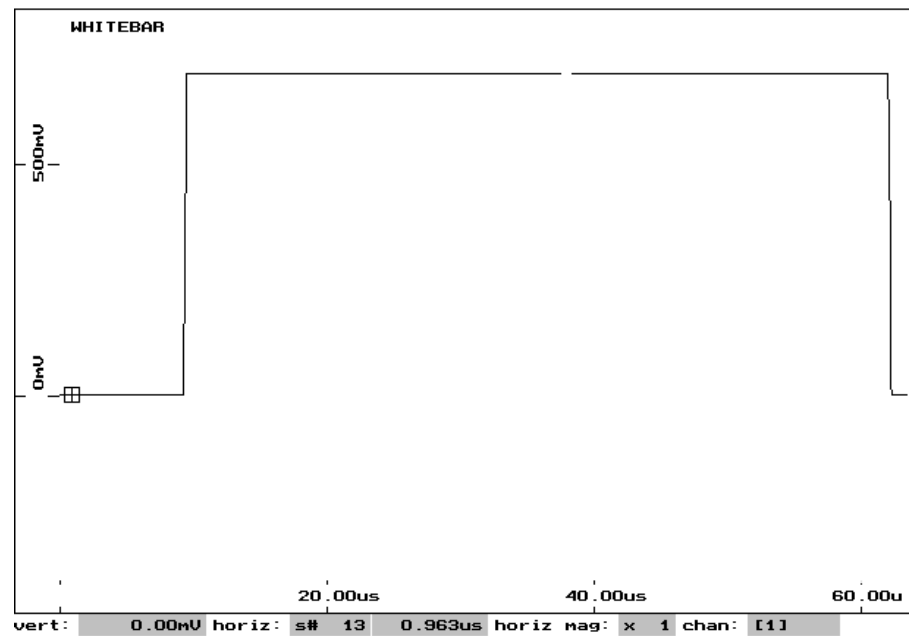

Figure 1-39: White bar (part of active picture timing test signal) — Y channel

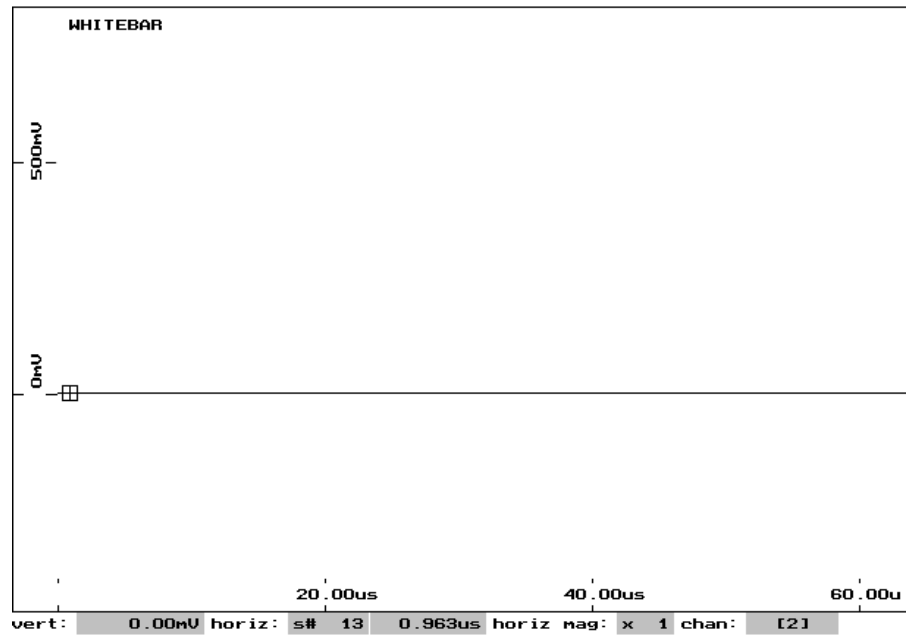

Figure 1-40: White bar (part of active picture timing test signal) — C_B and C_R channels

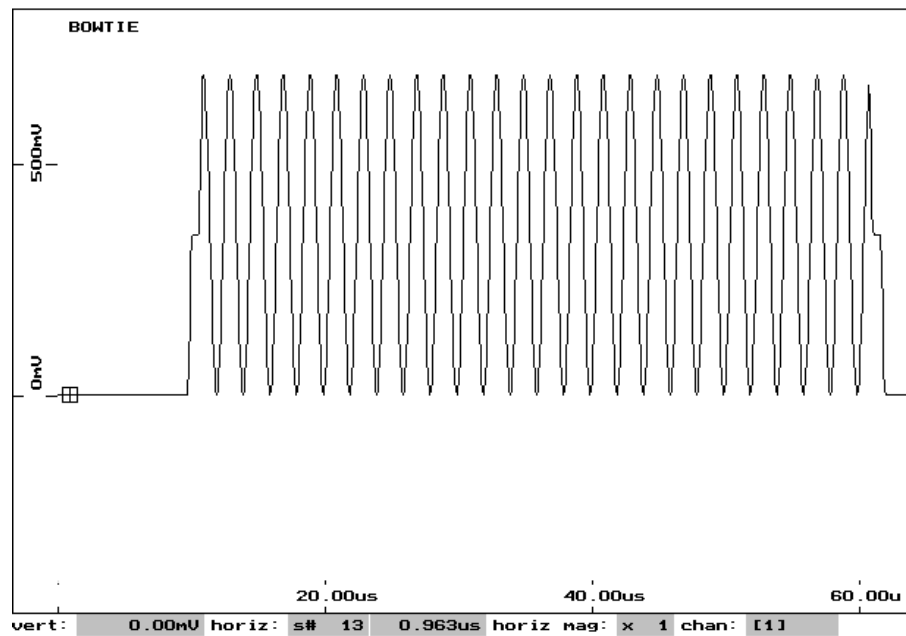

Figure 1-41: Bowtie sweep — Y channel

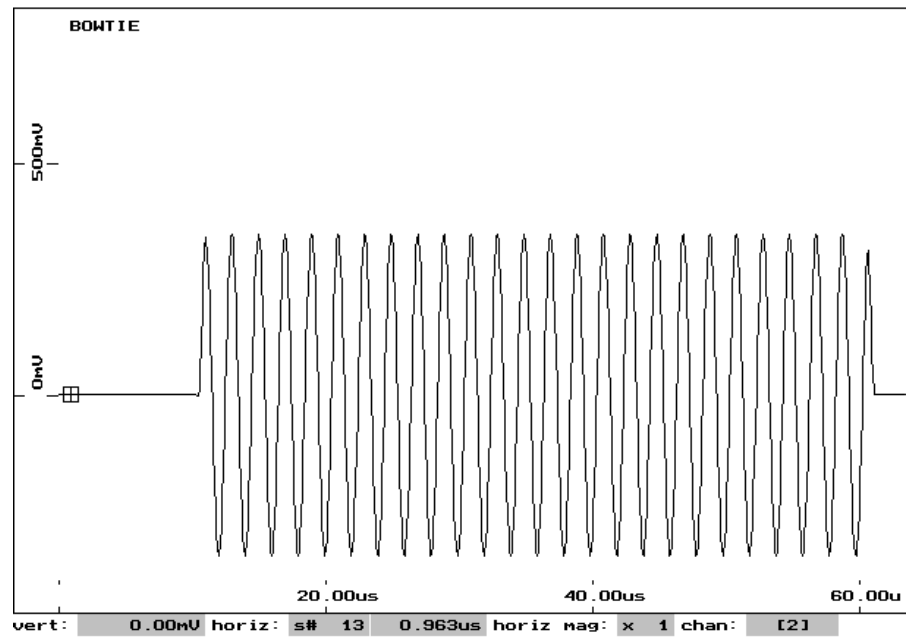

Figure 1-42: Bowtie — C_B and C_R channels

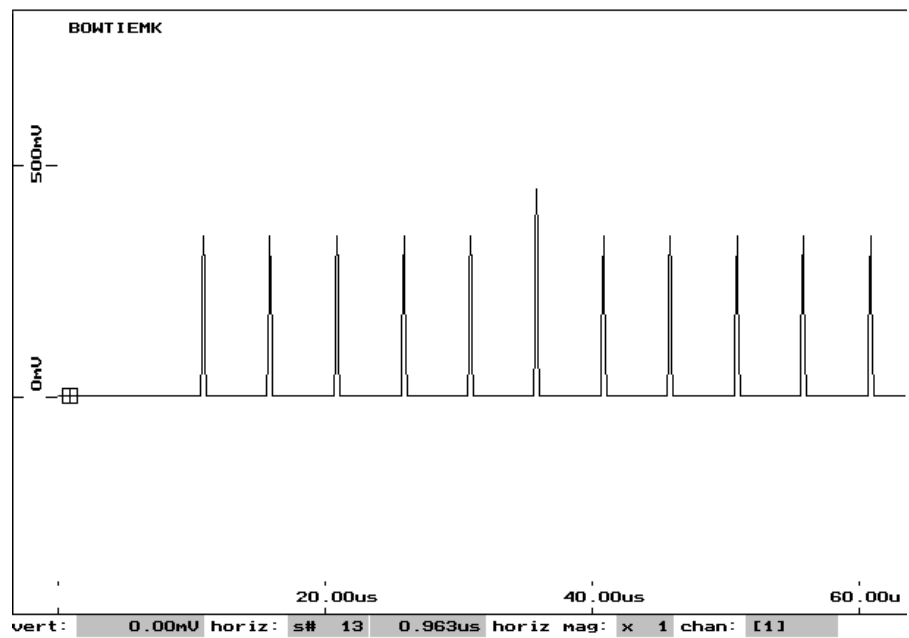

Figure 1-43: Bowtie markers — Y channel

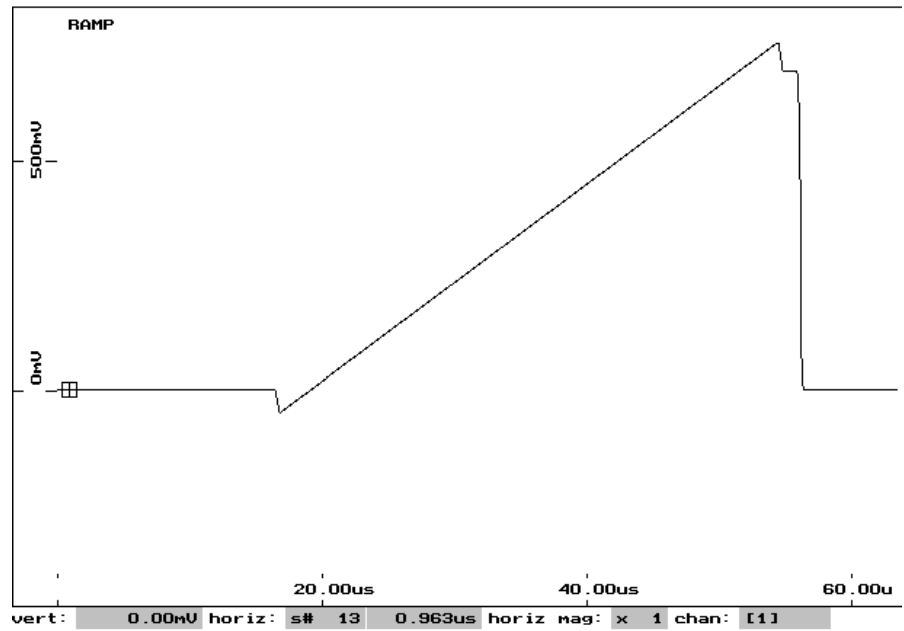

Figure 1-44: Ramp — Y channel

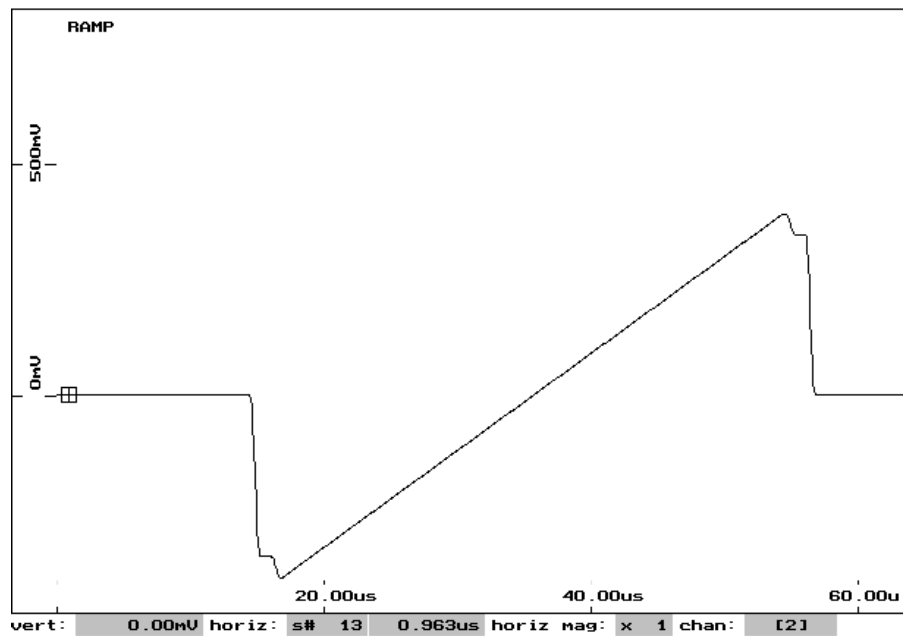

Figure 1-45: Ramp — C_B channel

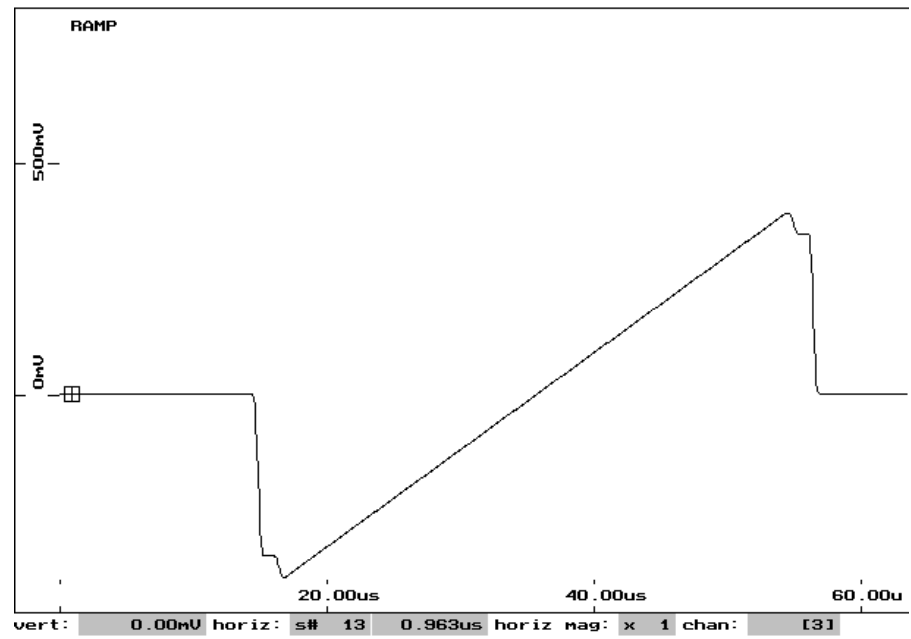

Figure 1-46: Ramp — C_R channel

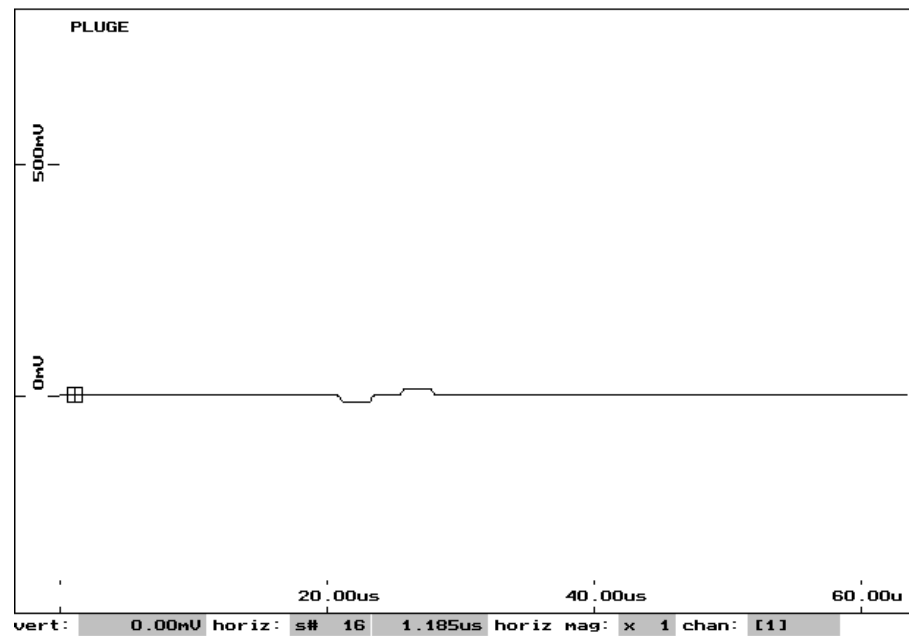

Figure 1-47: Pluge — Y channel

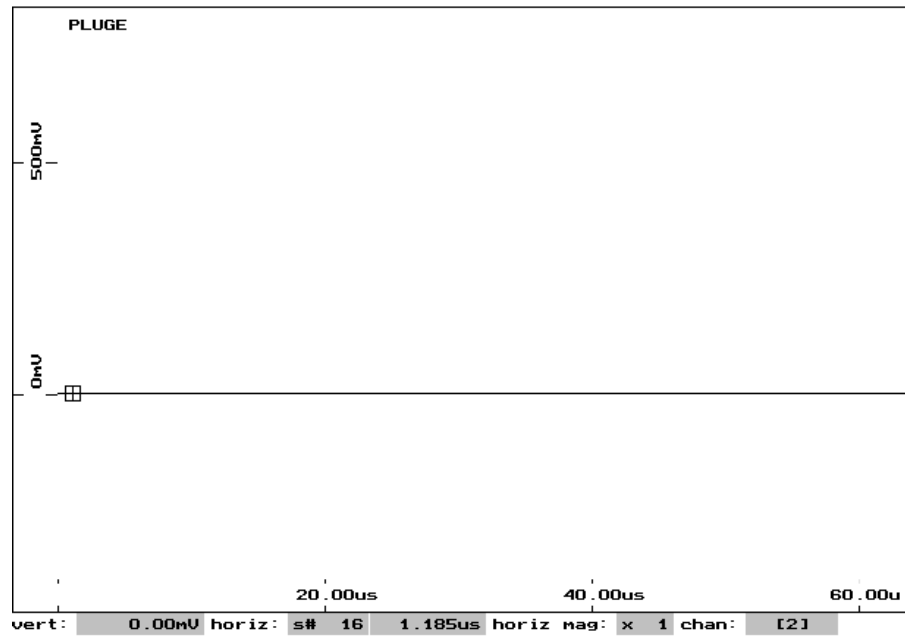

Figure 1-48: Pluge — C_B and C_R channels

Functional Overview

There is one input and several different kinds of outputs available from the SPG 422. This section explains what these signals are and how to use them.

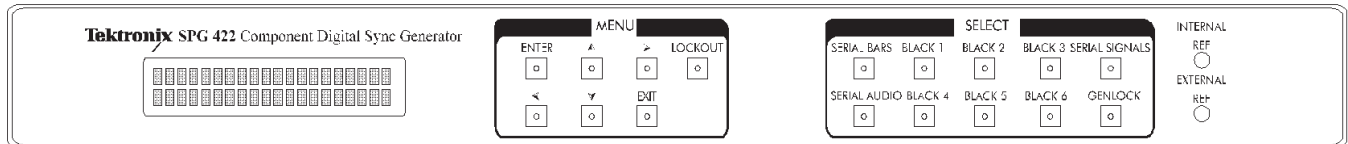

Figure 2-1: SPG 422 front panel

Genlock

The genlock input accepts either NTSC, PAL, or CW inputs. The SPG 422 expects the input to be an Analog Black reference signal either with or without burst. If burst is not present, then the SPG 422 can lock to the sync (instead of burst lock). Configure the genlock as either a loophthrough or two terminated inputs.

The user can change the timing to compensate for any delays inherent in their system.

Please note that the SPG 422 cannot auto-detect the genlock input standard. Configure the genlock through the front panel or the RS-232 remote control. Setting up the genlock Input signal has three parts: selecting video standard, selecting input configuration, and setting timing offset.

Genlock Video Standard

There are two different video standards to choose from (NTSC or PAL). Also you can choose between burst lock and sync lock.

You can also select from a list of continuous wave frequencies: 3.58, 4.43, 1.0, 5.0, or 10.0 MHz.

If the genlock is set to burst lock but the Input signal has no burst or it suddenly loses burst, the menu display of the SPG 422 will say: "Reference Unknown". All output signals will remain locked to the internal oscillator.

Genlock Input Configuration

Connect the genlock signal in three different ways. Figure 2–2 illustrates the various options.

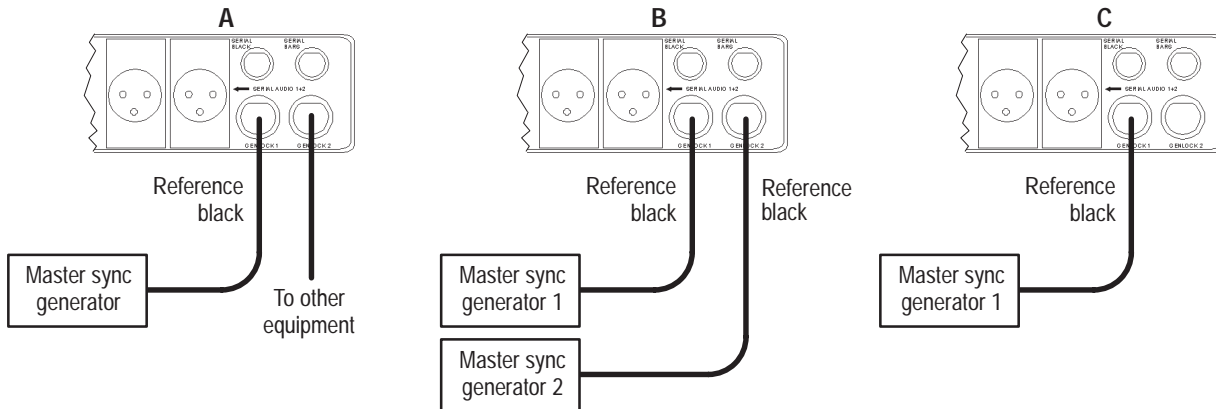

Figure 2–2: Various ways genlock input can be configured

Figure 2–2A shows the genlock as a loopthrough signal from genlock A to genlock B. This application is common when the SPG 422 is close to the master sync generator and the master sync still has other equipment to feed.

Figure 2–2B shows two possible genlock inputs: Genlock 1 and Genlock 2. These are two different references. You can select which one you want from the front panel (remember that the unselected genlock input is still terminated). An application for this setup is a dual standard suite. One genlock input would be the 525/59.94 standard and the other 625/50 standard. Set some blacks for each standard, and the user can quickly shift between the standards with a menu change.

Figure 2–2C shows a single genlock input. This is appropriate for the last signal in a reference chain.

Genlock Timing

The commands under this menu set the amount of advance or delay for all the output signals relative to the genlock input. The individual signals can then have their timing adjusted in their own menus.

You do not need to press **ENTER** for these commands. All changes will occur as you make them.

The submenus for genlock timing are: field timing, vertical offset, horizontal offset, and fine horizontal offset.

Genlock Field Timing	Sets the amount of field offset using the left or right arrows. The maximum amount of offset is two fields of advance or delay.
Genlock Vertical Offset	The genlock vertical offset sets the amount of vertical offset using the left and right arrows. The changes are immediate (you do not need to press ENTER to see the results). The amount of offset can range from eight lines advance to eight lines delay.
Genlock Horizontal Offset	Genlock horizontal offset sets the amount of horizontal offset using the right or left arrow keys. It will move in units of clock cycles so the exact amount will vary depending upon the video standard selected. The total range of the horizontal offset is $\pm\frac{1}{2}$ line.
Genlock Fine Horizontal Offset	Genlock fine horizontal sets the fine horizontal timing. These increments are in sub-clock-cycle units. The total range of the fine horizontal offset is $\pm\frac{1}{2}$ line.

Black Signals

There are at least two analog black outputs available from the rear panel. (If the SPG 422 is Option 1, then there are six analog black outputs.) Configure each separately for standard, timing, and signal type. If the selected standard is different from the genlock input, then it locks to the internal oscillator that is “clock-locked” to the genlock input. The timing offset range is ± 2 fields and $\pm 8\frac{1}{2}$ lines.

Bars Signals

The bars BNC connector outputs serial digital component color bars in either the 525 or 625 standard. A timing shift of ± 1 field and $\pm 8\frac{1}{2}$ lines is available. It is not necessary that the bars output and the genlock input be the same standard. If they are not the same standard, then the signal locks to the internal oscillator that is “clock-locked” to the genlock. Select all variables from the Bars signals menu.

Serial Black

The serial black signal is identical to the serial bars signal except the bars signal information has been stripped off and replaced with black. It takes its timing offset information directly from the serial bars signal.

Audio Signals

There are three different formats of serial audio signals available from the rear panel: AES/EBU from BNC connectors and from XLR connectors plus embedded audio in the serial digital video signal. If any audio parameters change, then all of the audio outputs are affected. Different audio tones and levels are available for each channel. Up to four channels are available. Turn them on or off and change the tone and levels independently.

Although the output frequency and amplitudes are the same, the AES and embedded audio are essentially generated by separate generators. Therefore, there is no consistent phase relationship between the two with respect to audio tones. The digital audio sample frames are synchronized with the video frame.

Serial Signals (Option 2 only)

If Option 2 is not installed then these outputs are plugged. Both outputs have identical signals. There are a wide variety of signals from which to choose. The timing offset relative to the genlock is selectable. The standard is selectable and can be independent of the genlock standard. If the standard is different from the genlock, then it takes its timing from the internal oscillator that is “clock-locked” to the genlock signal. Therefore, the signal will be clock-locked but not frame-locked to the genlock reference signal.

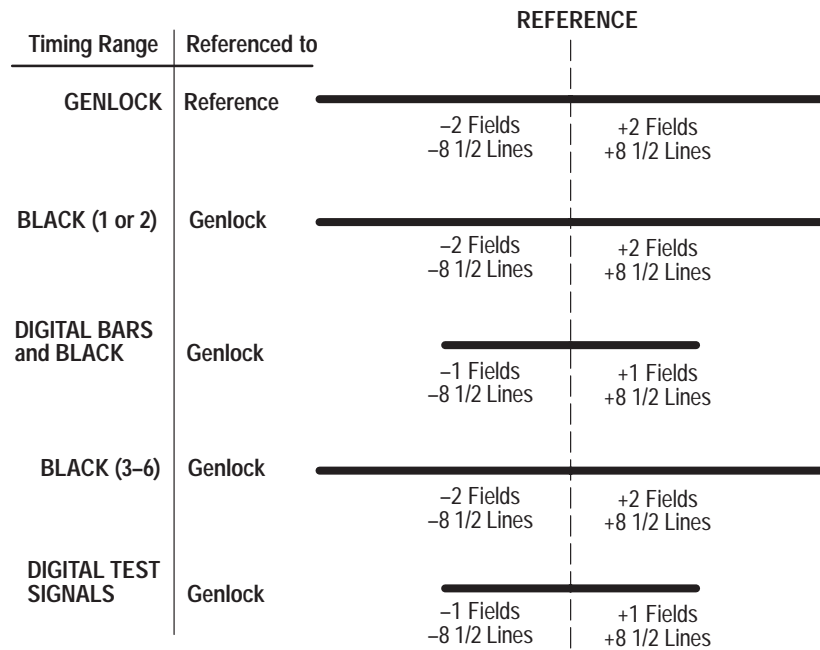

Figure 2-3: Illustration of SPG 422 timing

Theory of Operation

This section provides block-level information on how the SPG 422 circuitry works, for board-level troubleshooting. See Figure 3–1 for an SPG 422 block diagram. Component-level troubleshooting information is provided later, in a section titled Detailed Circuit Description.

Genlock

The Genlock input signal enters the circuit on the Output board through the rear-panel BNC connectors. The signal from the BNC is selected by the 2:1 Multiplexer. The signal then goes to the Sync Stripper that produces a clamped video signal and a luminance signal for use in the Chroma Filter. The Sync Stripper uses the output of the Chroma Filter to produce the luma and clamped video signal. The 2:1 Multiplexer selects the chroma and CW Bypass signals used as the Color Lock input.

On the Digital board, the outputs of the Sync Lock, Color Lock, Test, and Internal are put in a 4:1 multiplexer for use as the tune signal for the 13.5 MHz VCXO. The 13.5 MHz signal is then stepped up in frequency in the 108 MHz PLL that produces the 108 MHz and 27 MHz clocks. The Genlock Controller produces the Frame Resets. The Fine Phase circuitry generates delayed versions of the 27 MHz clock from the 108 MHz clock. The Frame Resets are then re-synchronized to these delayed clocks. The Fractional Divider uses the 27 MHz clock to produce the 6.144 MHz clock for the audio signals.

Front Panel Board

The Front Panel board consists of LEDs and switches. The LEDs light on commands from the CPU. The switches provide control commands to the CPU that determine the state of the output signals.

The Front Panel Interface converts the X-Y data format of the front-panel switches into data for the external data bus to control the microprocessor. If the front panel is disabled, then the commands from the front panel are not processed.

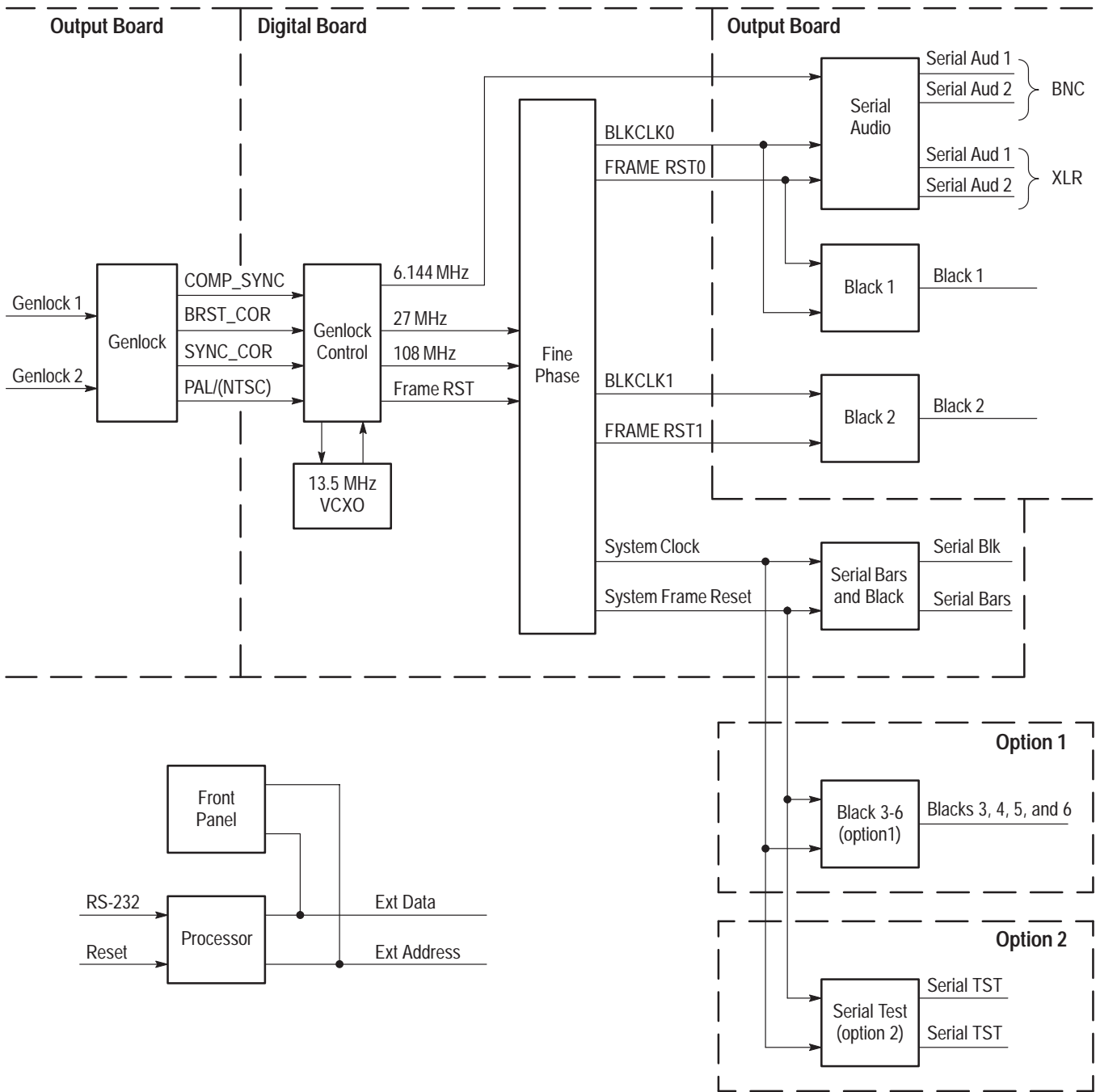

Figure 3-1: SPG 422 block diagram

Digital Board

The Digital Board CPU consists of the microprocessor and its associated memory and buffers.

The Ground Closure Parallel Remote consists of a latch that samples the remote data and places it on the external data bus whenever it is polled by the microprocessor.

The microprocessor sends data over the external data bus for conversion into driver signals for the front-panel LEDs.

The Display Data Latch consists of two parts. The first gets data from the external data bus and converts it into an analog voltage that controls the contrast of the front-panel display. The second part controls the actual characters displayed on screen.

The Test Signal Generator is a complete generator, requiring only a master clock, a synchronous frame reset, and setup information from the microprocessor. On startup, the processor writes the signal configuration information to the generator and downloads the necessary audio and video test signals into RAM.

Audio RAM data is the audio tone formatted in a specific format for AES audio. This data is read from the Audio RAMs at a particular point in the video data stream to be embedded. The audio data is placed into RAM by the microprocessor.

Controlled by signals from the CPU, the Genlock Type Selector selects which type of genlock signal to expect. The selected signal is then converted and used as the correction signal for the VCXO.

The heart of the VCXO is the Oven Oscillator Assembly, which takes the VCXO correction signal and a reference voltage to produce a 13.5 MHz instrument clock signal that is phase locked to the genlock input signal. All other timing signals are derived from this main reference clock signal.

Any errors with the oscillator are flagged with LEDs.

The main purpose of the Direct Digital Synthesizer is to produce the clock for the Burst Lock circuit and the edge strobe for the Sync Lock circuit.

The 108 MHz oscillator steps up the 13.5 MHz instrument clock to produce a 27 MHz clock and a 108 MHz clock.

The 27 MHz clock is used by the Genlock Controller and DDS. The Fine Phase and SCH measurement circuits use the 108 MHz.

The Fine Phase circuit consists of four identical circuits. The resulting signal is used to drive the test signal and option 1 timing.

The 6.144 MHz circuit produces the timing signals for the serial audio generation on the Output board.

Output Board

The Genlock input signals enter through the two rear-panel BNCs and is either terminated in $75\ \Omega$ or allowed to pass to the other input depending on the state of a signal from the Digital board. Another signal from the Digital board also further selects the input until only one of the two inputs is available.

The Sync Stripper takes the selected genlock input and produces two signals.

The Chroma filter has two purposes. First it strips chrominance information so that the Sync Stripper can use the luminance information to generate its reference signals. Second, it produces a reference signal that is the main genlock signal when the genlock is in the color lock mode.

The Burst Lock part of the Color Lock circuit takes signals from the Chroma Filter and Sync Stripper and converts them to signals for the rest of the instrument.

The Sync Lock circuit takes signals from the Sync Stripper and the Digital board and generates a signal that is sent to the Digital board.

The Black Clock Buffer converts the four black ECL clock signals to TTL levels for use on the Output board.

The Audio Generator consists of the controller PLD, Channel 1 and 2 RAM, and Channel 3 and 4 RAM.

The controller has five primary functions. First, it generates the RAM address needed by the microprocessor to write and read from the audio RAMs. Second, it generates the RAM addresses needed to read data out of the RAMs in real time. Third, it generates the control signals to control the RAMs. Fourth, it bidirectionally buffers the data between the external microprocessor data bus and the RAM data buses. The final function of the audio control PLD is to provide the user with the capability of offsetting the audio to the video timing. (This timing offset only relates to sample timing relative to video, not the timing offset of the audio blocks.) The microprocessor loads the 8-bit audio timing offset into a register in the PLD.

Audio parallel-to-serial converters take parallel audio data and convert it into a serial data stream.

The Audio Output circuit takes the signals from the parallel-to-serial converters and buffers, balances, and raises the amplitude to drive either the $100\ \Omega$ outputs or $75\ \Omega$ BNCs.

The two Black Burst Generators are nearly identical. The black burst generation circuit is a complete generator, requiring only a master clock, synchronous frame PAL and NTSC resets, and setup information from the microprocessor.

The black burst generator incorporates as much of the circuitry as possible into a large programmable logic device (PLD). The large, random look-up tables are done in EPROM.

The Black Burst Generator begins with a Frame Reset Generator that takes a PAL and an NTSC frame reset signal and selects between them, based on the signal standard chosen. This reset pulse is then delayed by an integer number of clock cycles specified by the microprocessor. This delayed reset pulse is used to synchronously reset the horizontal, vertical, and field counters. This programmable delay provides the instrument with a way to delay (or advance) the timing of the generator relative to the master timing source (the genlock). In the case of the two standard Black Burst Generators, the 27 MHz clock is also delayed in sub-nanosecond increments, under processor control, before it arrives at the generator. This allows fine control of output timing.

The clock and reset drive the counter chain. The first counter in the chain is the horizontal counter, an 11-bit up-counter that counts at 27 MHz and resets itself at the end of the video line. It is also reset by the frame-reset input. The line length is specified by the video standard selected. On the last count of the line, the counter outputs a horizontal carry pulse.

The horizontal segment data is used to divide the horizontal line into a small number of unique regions. This allows the storage of the actual signal data to be dramatically compressed.

The second counter in the chain is the vertical counter, a 10-bit up-counter that runs at 27 MHz. It is enabled to count once per video line by the horizontal carry pulse. It counts to the end of the frame in the selected video standard and resets itself. (It is also reset by the frame reset input.) On the last count of the frame, the counter outputs a vertical carry pulse.

The third counter in the chain is the frame counter, a 2-bit up-counter that runs at 27 MHz. It is enabled to count once per video frame by the horizontal and vertical carry pulses. It counts to the end of the color frame in the selected video standard and resets itself. (It is also reset by the frame reset input.)

The counters, horizontal segment decoder, and signal selection bits from the processor drive the segment decoder PROMs. These PROMs decode the counter and decoder inputs into pointers to unique blocks of eight samples of black-burst data.

Signal-segment data PROMs take the segment pointers from the decoder PROMs and output the 8-bit black-burst data.

The DAC and output circuitry converts the digital representation of black burst to analog, reconstructs the signal, filters it, and buffers it to drive 75 Ω .

Power Supply

The switching power supply generates 5 V for TTL and ECL devices. A stable linear supply of 12 V is provided for powering the analog circuitry.

This type of power supply is called a current-mode-controlled, discontinuous, flyback, switching power supply. The current output is distributed between the four supplies as follows:

+ 12 V	0.8 Amps max
+5 V	7 Amps max
-5 V	6 Amps max
-12 V	0.8 Amps max

The maximum power is limited by the maximum current in the primary of the power inductor. This is also the only current limit for the ± 5 V supplies, as they have no secondary current limit. The ± 12 V supplies are current limited on the secondaries by the ± 12 V linear regulators and the secondary ± 14.5 pulse width modulator.

There is also circuitry to provide for operation from both 110 and 220 VAC supplies, over-voltage protection (crowbar) on the +5 V supply, and shutdown circuitry that forces a restart of the supply if it remains in current limit for more than a short period of time (≤ 200 ms).



WARNING. All primary voltages are referenced to a floating ground, not chassis ground. Potentials to chassis ground can be much higher and the possibility exists that you could electrocute yourself.

Option 1 Board

The SPG 422 Option 1 board contains four identical, separate dual-standard black generators. Each generator runs on a 27 MHz master clock, with PAL and NTSC frame resets to synchronize them and some microprocessor setup information to program them.

The four black generators are controlled by the microprocessor and the Controller PLD, which takes the video standard selection for each channel and selects and processes the appropriate frame reset pulse for each generator. The Controller PLD also generates the necessary microprocessor interface signals for each Encoder.

Option 2 Board

The Option 2 board produces the additional serial digital test signals that are available when Option 2 is installed in the SPG 422. The circuitry is identical to the Bars generation in the standard instrument.

The Test Signal Generator is a complete generator, requiring only a master clock, a synchronous frame reset, and some setup information from the microprocessor. On startup, the processor writes the signal configuration information to the generator and downloads the necessary audio and video test signals into RAM.

Detailed Circuit Descriptions

This section provides detailed circuit descriptions.

Logic Conventions

Signal names are all capital letters, for example, SIGNAL.

An active low signal (normally denoted by an overscore) is a signal name enclosed in parentheses, (SIGNAL).

The aside of a signal name is always in square brackets, for example, [SIGNAL].

The aside of an active-low signal is also the signal name in square brackets, for example, [(SIGNAL)].

Front Panel Board

The Front Panel board consists of LEDs and switches. The LEDs light on commands from the CPU, [L0-L17]. The switches provide control commands to the CPU that determine the state of the output signals.

Digital Board CPU <1>

The CPU consists of the microprocessor, U3, and its associated memory and buffers. U11 contains the serial bars data. U10 contains the audio data and CPU codes. U6 is the external data-bus buffer, while U7 and U8 are the external address buffers.

Digital Board CPU I/O <2>

The Ground-Closure Parallel Remote. This consists of a latch that samples the remote data and places it on the external data bus whenever it is polled by the microprocessor.

Front-Panel Switch Interface. The Front Panel Interface converts the X-Y data format of the front-panel switches into data for the external data bus to control the microprocessor. If the front panel is disabled, then the commands from the front panel are not processed.

Front-Panel LED Drivers. The microprocessor sends data over the external data bus, and U14, U15, and U16 convert the commands into driver signals for the front-panel LEDs, L[0..19].

Display Data Latch. The Display Data Latch consists of two parts. The first part gets data from the external data bus and converts it into an analog voltage, U22, that controls the contrast of the front-panel display. The second part controls the actual characters displayed on the screen, U17.

Serial Video Generation <3>

The Test Signal Generator is a complete generator, requiring only a master clock, (SCBCLK); a synchronous frame reset, (SCBFRP) or (SCBFRN); and some setup information from the microprocessor. On startup, the processor writes the signal configuration information to the generator and downloads the necessary audio and video test signals into RAM.

Horizontal, Vertical, and Field Counters and Decoding PLDs. U25 and U34 are the Horizontal, Vertical, and Field Counters and Decoding PLDs.

The clocks and reset drive the counter chain. The counter drive state machine selects the proper test signal RAM address at the correct time in the field.

Timing Reference Signal Generator. U36 is the Timing Reference Signal (TRS) Generator. It gets the appropriate TRS data addresses and loads them into the Serial Bars RAMs so that the data is multiplexed into the video signal.

Serial Bars RAM. U26 and U27 are the Serial Bars RAM. Each line of the video signal is stored in sample order, with each video line bottom-justified in memory on 1 kB boundaries. The required video signals are downloaded into the RAM at power-up and are not changed during operation unless the video standard is changed.

The Serial Bars RAMs output, SCBD[0..9], is the parallel video signal with the TRS data loaded.

Serial Coprocessors <4>

Audio Data RAM. The data in the Audio RAMs is the audio tone in a specific format for AES audio. This data is read out of the Audio RAMs at a particular point in the video data stream to be embedded. The audio data is placed into RAM by the microprocessor by using the address, EA[0..14], and data ED[0..7] buses and the various control signals.

Serial Digital Coprocessor and Serial Blanker Coprocessor. The parallel digital video data with TRS inserted, SCBD[0..9], enters U45. The audio data is then multiplexed into the data on the data stream from the Audio Data RAMs, U42

and U43. The video data with embedded audio exists from U45 on the SER DIG[0..9] bus and enters into U44 as the serial data test signal, SDT[0..9]. There the video stream splits in two. EDH data is embedded into one of the data streams, scrambled, and exits U44 as the serial digital test signal, SDT[0..9]. The other data stream is converted into a black signal, EDH data is embedded, scrambled, and exits U44 as the serial digital black signal, SDB[0..9].

The Coprocessors are programmed by the microprocessor from the data stored in U11 <1>. The audio data is a part of the data in EPROM, U10 <1>.

Serial Video Outputs <5>

The serial black, SDB[0..9], and serial bars, SDT[0..9], signals are serialized by U48 and U49, respectively. U47 and U46 are the Serial Output drivers for the signals.

13.5 MHz Genlock Control <6>

Genlock Type Selector 4:1 MUX. Controlled by signals from the CPU, U50 selects which type of genlock signal to expect. The selected signal is then converted to VCO_TUNE and used as the correction signal for the VCXO.

13.5 MHz VCXO. The heart of the VCXO is the Oven Oscillator Assembly. It takes the VCXO correction signal and a reference voltage to produce the 13.5 MHz instrument clock signal that is phase locked to the genlock input signal. The 13.5_OSC signal is this main reference clock signal. All other timing signals are derived from this signal.

Any errors with the oscillator are flagged with LEDs. DS4 will light if the VCO_TUNE signal is greater than its threshold level. This indicates that the oscillator is not in its acceptable level. DS1 will light if the oscillator is under temperature. The oscillator is not considered stable until this light goes out (after an approximate 20-minute warm-up time).

Direct Digital Synthesizer. The main purpose of the Direct Digital Synthesizer, U82, is to produce the F_{SC} clock for the Burst Lock circuit and the Edge Strobe for the Sync Lock circuit.

108 MHz Oscillator <7>

The purpose of the 108 MHz oscillator is to step up the 13.5 MHz instrument clock to produce the 27 MHz clock and the 108 MHz clock.

The 27 MHz clock is used by the Genlock Controller and DDS. The Fine Phase and SCH measurement circuits use the 108 MHz.

DS2 lights if the 108 MHz loop is unlocked.

Fine Phase Control Signals. U91 uses the change angle signals from the Genlock Controller to generate clocks that are slightly off phase from the main 27 MHz

clock. These signals are clocked by the 108 MHz clock through the D-Q flip-flops. F_PHASE signals then go to the Fine Phase circuits <8>.

DDS Clock Generator. The 27 and 108 MHz signals are combined in D-Q flip-flop U108A to produce the DDSCLK and 27CLK0 signals for the DSS 6.144 MHz circuit <9>.

108 MHz Oscillator. The 108 MHz oscillator uses the 13.5 MHz clock from U87 and multiplies the frequency by a factor of 8 to produce the 108 MHz clock. The 108 MHz signal is used to clock the Fine Phase Control and SCH Measurement circuits.

Fine Phase <8> The Fine Phase circuit consists of three identical circuits, therefore only the Genlock Fine Phase Adjustment circuitry is described.

F_PHASE0 and (F_PHASE0) come from the Fine Phase Control circuit <7> and generate clock signals that can be set to any phase with respect to the base 27 MHz clock signal. The resulting signal is used to drive the test signal and option 1 timing.

DDS 6.144 MHz <9> This circuit produces the timing signals for the serial audio generation on the Output board.

Output Board

Genlock Input <1> See Figure 3–2.

Genlock Selector 2:1 MUX. The Genlock input signals enter through the two rear-panel BNCs. The first relay, K1, either terminates the input side in 75 Ω or allows it to pass to the other input depending on the state of the REF DUAL signal from the Digital board. On instrument serial number B020518 and above, K1 is a latching relay that prevents a state change when power is lost. The REF1/2, also from the Digital board, then further selects which input until only one of the two inputs is available as the MUX_VIDEO signal.

Sync Stripper. The Sync Stripper, U10, takes the selected genlock input, MUX_VIDEO, and produces the REF_VIDEO, (COMPSYNC), and (HDRIVE) signals.

Chroma Filter. The Chroma filter has two purposes. First it strips the MUX_VIDEO signal of any chrominance information so that the Sync Stripper can use the luminance information to generate its reference signals. Second, it produces the REF_CHROMA signal which is the main genlock signal when the genlock is in the color lock mode.

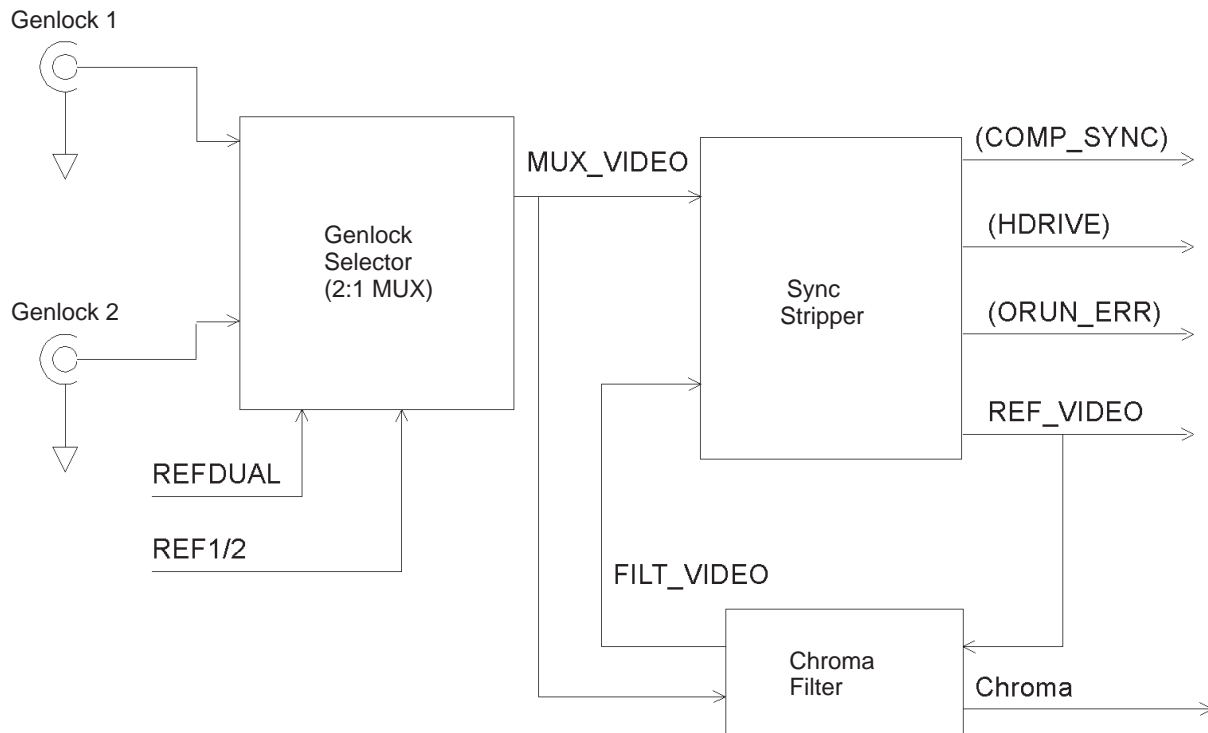

Figure 3-2: Block diagram of genlock Input <1>

Burst and Sync Locks <2> See Figure 3-3

Burst Lock The heart of the Color Lock circuit is U11. It takes the REF_CHROMA from the Chroma Filter and the COMP_SYNC signal from the Sync Stripper and converts them to signals for the rest of the instrument: BRST_COR, (BRST_LK), and H/2_ERR.

Sync Lock The Sync Lock circuit takes the REF_VIDEO signal from the Sync Stripper and the EDGEST signal from the Digital board and generates the SYNC_COR signal. The SYNC_COR signal is then sent to the Digital board.

Black Clock Buffer U1 (and U60 for board version -01 and up), the Black Clock Buffer, converts the four black ECL clock signals to TTL levels for use on the Output board.

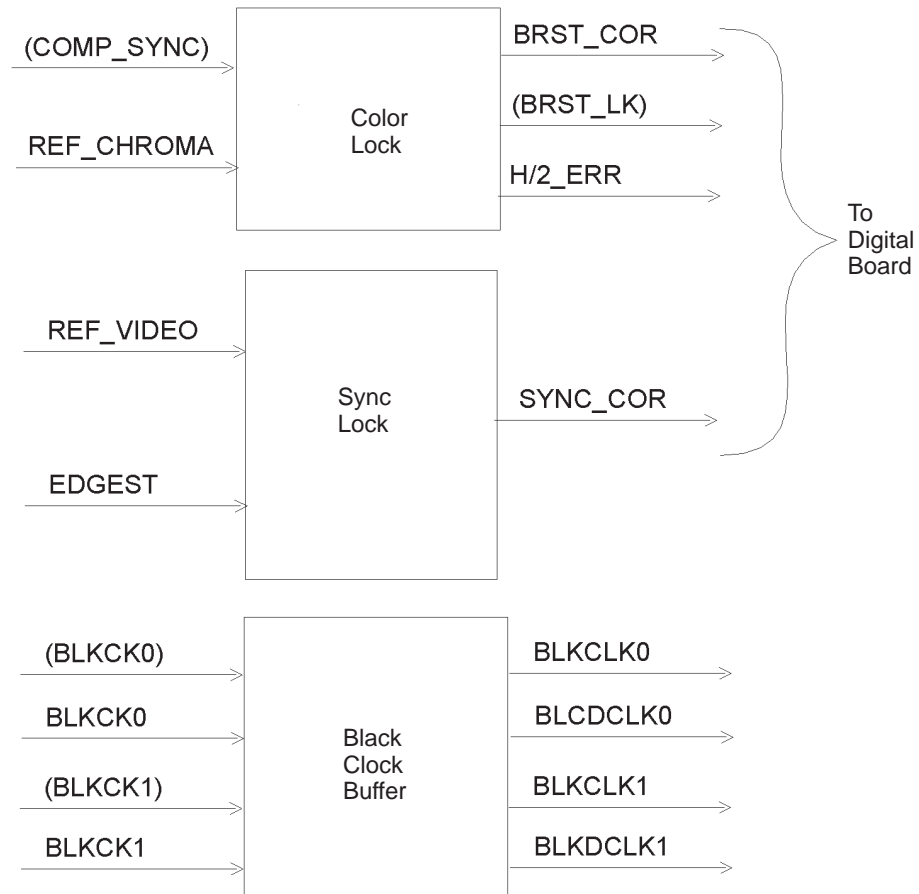

Figure 3-3: Block diagram of burst and sync locks <2>

Serial Audio Outputs <3>

Audio Generator. The Audio Generator consists of U24 (the controller PLD), U22 (Channel 1 and 2 RAM), and U23 (Channel 3 and 4 RAM).

The controller contains an address counter that free-runs on a clock locked to the serial test signal output clock, at the audio data output bit-rate (6.144 MHz). It continuously reads out the audio data. It also has another counter that can be single-stepped by the microprocessor for downloading audio data. The microprocessor gets audio frequency and amplitude and status bits from the user or the NVRAM, generates the audio data stream, inserts the CRC, and downloads it into RAM.

The controller has five primary functions.

1. Generate the RAM address needed by the microprocessor to write and read from the audio RAMs (U22 and U23).

2. Generate the RAM addresses needed to read data out of the RAMs in real time.
3. Generate the control signals to control the RAMs.
4. Buffer bi-directionally the data between the external microprocessor data bus and the RAM data buses.
5. Provide the user with the capability of offsetting the audio to the video timing.

The timing offset relates only to sample timing relative to video, not the timing offset of the audio blocks. The microprocessor loads the 8-bit audio timing offset into a register in the PLD.

Audio Parallel-to-Serial Converters. U18 and U19 take the audio data, in parallel form, and convert it into a serial data stream.

Audio Outputs. The Audio Output circuit takes the signals from the Parallel to Serial Converters and buffers, balances, and raises the amplitude to drive either the 100 Ω outputs or 75 Ω BNCs.

Black Burst Generator #1 <4> and Black Burst Generator #2 <5>

Black Burst Generator #1 and #2 are nearly identical, therefore only #1 is described.

The black burst generation circuit is a complete generator, requiring only a master clock [BLKCLK0], synchronous frame PAL and NTSC resets [(BLKFNP0) and (BLKFRN0)], and some setup information from the microprocessor [ED[0..7]].

The black burst generator incorporates as much of the circuitry as possible into a large programmable logic device, PLD. The large, random look-up tables are done in EPROM.

Black PLD (U31). The Black Burst Generator begins with a Frame Reset Generator that takes a PAL and an NTSC frame reset signal and selects between them, based on the signal standard chosen. This reset pulse is then delayed by an integer number of clock cycles specified by the microprocessor. This delayed reset pulse is used to synchronously reset the horizontal, vertical, and field counters. This programmable delay provides the instrument with a way to delay (or advance) the timing of the generator relative to the master timing source (the genlock). In the case of the two standard Black Burst Generators, the 27 MHz clock is also delayed in sub-nanosecond increments, under processor control, before it arrives at the generator. This allows fine control of output timing. (See Fine Phase <8> on the Digital board.)

The clock and reset drive the counter chain. The first counter in the chain is the horizontal counter. This 11-bit up-counter counts at 27 MHz and resets itself at the end of the video line. It is also reset by the frame reset input, either (BLKFRN0) or (BLKFRP0). The line length is specified by the video standard selected. On the last count of the line, the counter issues a horizontal carry pulse.

The horizontal segment decoder is implemented in a state machine. This state machine uses the outputs of the horizontal counter and some special timing control signals from the horizontal counter. The horizontal segment data is used to divide the horizontal line into a small number of unique regions. This allows the storage of the actual signal data to be dramatically compressed.

The second counter in the chain is the vertical counter. This is a 10-bit up-counter that runs at 27 MHz. However, it is only enabled to count once per video line by the horizontal carry pulse. It counts to the end of the frame in the selected video standard and then resets itself. (It is also reset by the frame reset input.) On the last count of the frame, the counter issues a vertical carry pulse.

The third counter in the chain is the frame counter. It is a 2-bit up-counter that runs at 27 MHz. However, it is only enabled to count once per video frame by the horizontal and vertical carry pulses. It counts to the end of the color frame in the selected video standard and then resets itself. (It is also reset by the frame reset input.)

Segment Decoder PROMs. The counters, the horizontal segment decoder, and the signal selection bits from the processor drive the segment decoder PROMs. There is one PROM for NTSC, U38, and two (to get the required output bus width) for PAL, U36 and U37. These PROMs decode the counter and decoder inputs into pointers to unique blocks of eight samples of black burst data.

Signal Segment Data PROMs. The signal segment data PROMs, U39 and U40 (which are time-multiplexed to double the speed), take the segment pointers from the decoder PROMs and output the 8-bit black burst data.

DAC and Output Filter. The DAC, U32, and output circuitry convert the digital representation of black burst to analog, reconstruct the signal, filter it, and buffer it to drive 75 Ω .

Power Supply

The switching power supply generates 5 V for TTL and ECL devices. A stable linear supply of 12 V is provided for powering the analog circuitry.

This type of power supply is called a current-mode-controlled, discontinuous, flyback, switching power supply. The current output is distributed between the four supplies as follows:

+ 12 V	0.8 Amps max
+5 V	7 Amps max
-5 V	6 Amps max
-12 V	0.8 Amps max

The maximum power is limited by the maximum current in the primary of T1. This is also the only current limit for the ± 5 V supplies, as they have no secondary current limit. The ± 12 V supplies are current limited on the secondaries by the ± 12 V linear regulators, U150 and U152, and the secondary ± 14.5 pulse width modulator, U200.

The power inductor, T1, is driven by switching the voltage to its primary winding on and off at a rate of approximately 60 kHz. T1 is not used as a transformer, but as an energy storage device; the energy is stored in the primary during the first half of the switching cycle, while voltage is being applied. On the second half of the switching cycle, voltage to the primary is switched off and the energy stored in T1 is transferred to the secondaries. Regulation is accomplished by feedback from the +5 V supply to the Pulse Width Modulator controlling voltage to the primary. This varies the length of time that voltage is applied to the primary, causing it to store either more or less energy.

There is also circuitry to provide for operation from both 110 and 220 VAC supplies, over voltage protection (crowbar) on the +5 V supply, and shutdown circuitry that forces a restart of the supply if it remains in current limit for more than a short period of time ≤ 200 ms).



WARNING. All primary voltages are referenced to a floating ground, not chassis ground. An isolation transformer or a differential amplifier is therefore required for troubleshooting the circuitry in the primary and the Pulse Width Modulator, and in the supporting circuits. Potentials to chassis ground can be much higher and the possibility exists that you could electrocute yourself.

Input, AC to DC Converter, and Voltage Doubler

This circuitry filters and rectifies the input AC voltage, charging capacitors C845 and C865 to approximately 320 VDC.

The line current passes through line filter LF950, fuse F940, and power switch S930, and is applied to rectifier CR820. At the input of CR820, P810 is used to

select between 110 V and 220 V operation. If J810 is placed on P820, for 220 V operation, CR820 works as a full-wave rectifier and C845 and C865 act in series, charging to the peak voltage (approximately 320 VDC) during the first part of each one-half cycle. They then maintain that voltage through the rest of the cycle, as the input voltage and current fall to zero.

If, on the other hand, P810 is placed on J810 (for 110 V operation), CR820, C845, and C865 act as a half-wave rectifier and voltage doubler. During the positive half-cycle of the AC input only one of the diodes within CR820 conducts, charging C865 to the peak positive voltage. A different diode within CR820 conducts during the negative half-cycle, and charges C845 to the negative peak. The total voltage across C845 and C865 is then approximately 320 VDC.

E920 and E820 limit voltage surges on the input that might pass the line filter, while R865 and R845 discharge C865 and C845 when the power is off. DS720 and associated parts form a relaxation oscillator, so DS720 blinks when the instrument is powered up. L700, C5, C6, and C700 form a filter to keep noise developed by the Power Supply from getting onto C865 and C845 and out the line cord.

Kick Starter, Housekeeping Supply

These circuits supply the power to start and maintain oscillation of the Pulse Width Modulator, so long as the input AC voltage is sufficient to maintain regulation. When the power supply is first turned on, C656 charges through R921. When the charge across C656 reaches approximately 16 V, U722 begins to switch Q638 on and off through the base drive circuitry (Q648, and associated circuits).

The power to maintain the +16 V charge on C656 is now provided by the housekeeping winding of T1, pins 5 and 6, through CR600. If there is insufficient power to maintain the charge on C656 for any reason, such as the removal of P660, then the charge on C656 is quickly depleted. U722 will turn off when the voltage on C656 drops to approximately 10 V. Then, C656 will slowly charge again through R921, and the kick start sequence will be repeated. P660 may be used as a troubleshooting jumper, to trigger and verify the kick start sequence before applying power to T1 through P500.

Power Inductor Operation

The heart of this power supply is T1, the multi-winding power inductor. The operation of T1 is as follows (see Figure 3–4). Inductor T1 is initially uncharged (has zero magnetic flux). Q638, acting as a switch, is turned on by the base drive from U722. This places the charge developed on C545 and C865 (approximately 320 V) across the primary winding. The polarity of this charge is such that the voltages induced in the secondaries all reverse bias their respective diodes (note the polarity dots). In this way, there is no current flowing in the secondaries while current is flowing in the primary.

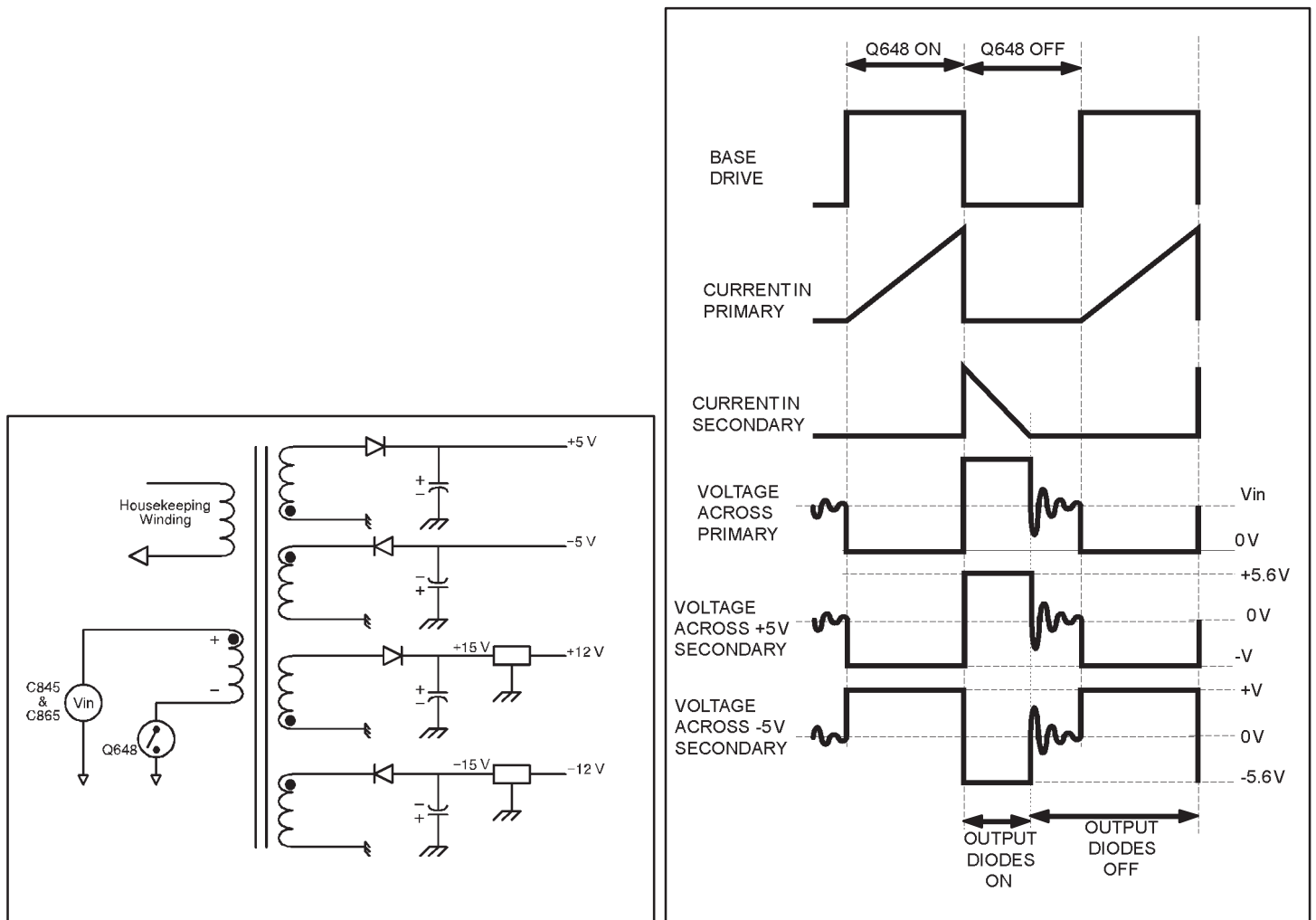

Figure 3-4: Power inductor circuit

The primary current builds as a linear ramp, storing the energy in T1 according to the relationship $E = \frac{1}{2} Li^2$, where L is the primary inductance and i is the current flowing through it.

The current path is broken when Q638 is switched off, so current stops flowing in the primary. The flyback action of T1 then causes the voltages in the secondaries to reverse polarities, and CR575 and CR320 to turn on.

The current in the secondaries linearly ramps down as the energy that was stored in T1 primary is delivered to the load, charging the output capacitors.

When all of the energy that was stored in T1 during the first half of this cycle is delivered to the load, the current in the secondaries is at zero, and the diodes turn off. There is no current flowing in either the primary or the secondaries until

Q638 is turned back on to start the next cycle. As there is not a continuous flow of energy in T1, this is called discontinuous flyback operation. At low line voltages or high loads all the power in inductor T1 may not be transferred to the load during the second half of the cycle, in which case the diodes will not be off when Q638 turns back on. In that case there will also be some energy still stored in T1 at the end of the cycle (at low line or high load).

Load regulation is provided by sensing the +5 V supply with a divider comprised by R314, R315, and R415, and using U410 to convert this to an error signal. This error signal is optically coupled through U520 back to the Pulse Width Modulator, U722. U722 uses the error signal to vary the width of the pulse that drives Q638.

When the +5 V goes too high, U722 narrows the pulse width. This reduces the amount of energy stored in T1, and therefore the amount transferred to the load, so the +5 V goes down. Contrariwise, when the +5 V is too low, the pulse width is increased, increasing the amount of energy stored in T1 and then transferred to the load, so the voltage goes up.

Pulse Width Modulator and Error Amplifier

See Figure 3–5.

The Pulse Width Modulator, U722, is a current-mode controller. It uses inputs from the primary circuit and from the +5 V output to vary the width of the pulse that controls Q638, as mentioned above. This regulates the secondary voltages throughout variations such as input voltage, output load, and temperature.

Current mode control works by allowing the current flowing in the primary to reach a peak level that is set by the output of the error amp (internal to U722), which is controlled by the +5 V output. The current in the primary winding is sensed by R630, and applied to U722-3 as a voltage. At the start of the cycle the oscillator sets the flip-flop within U722, which turns Q638 on. The primary current, and therefore the voltage to U722-3, ramps up until the I - SENSE level is sufficient to trip the comparator. This resets the flip-flop, ending the drive pulse to Q638, and the energy stored in the transformer is transferred to the secondaries.

Line regulation is accomplished automatically without voltage feedback. As the input voltage increases, the slope of the ramp increases, and the trip point is reached sooner. This results in a shorter pulse width. A decrease in line voltage causes a decrease in the slope of the ramp, and it takes longer to reach the trip point. The same peak current is reached in both cases, however, so the same amount of energy is transferred to the load. Line regulation, then, is achieved before variations in output voltage can occur.

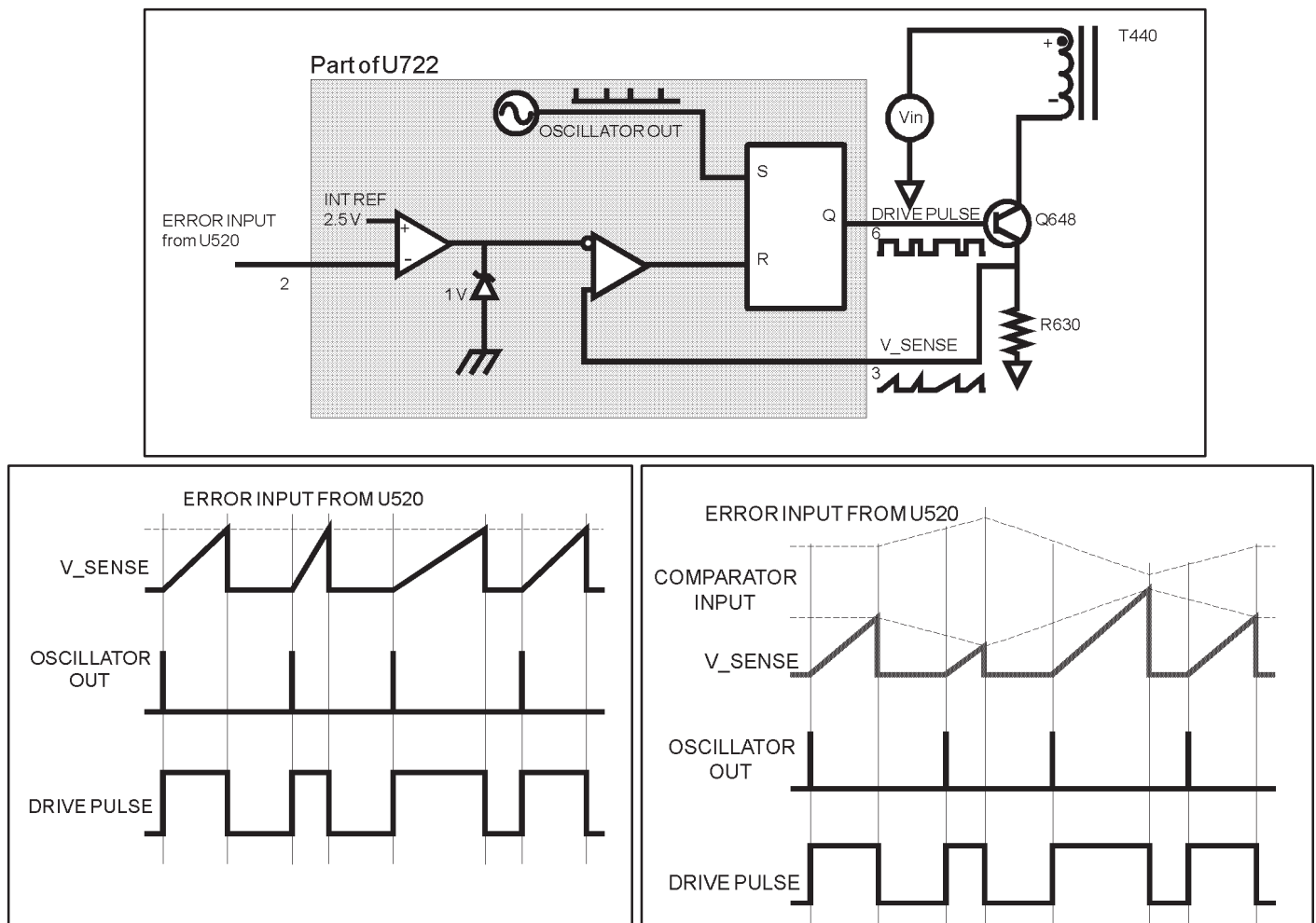

Figure 3-5: Pulse width modulator and error amplifier circuit

Load regulation is accomplished by sensing the output voltage of the +5 V supply and comparing it to a 2.5 V reference (internal to U410). U410 is a band-gap reference set to function as an error amp. Pin 3 of U410 is the error signal; this signal is coupled to U722 through opto-isolator U520. If the load increases, the signal at U722-2 drops in voltage. This causes U722 to increase the pulse width, and thus the current and power through T1.

On the other hand, if the load decreases, the +5 V increases momentarily. The output pulse width then decreases along with the current in T1, and less power is transferred to the secondaries. In this way, the +5 V is kept constant through changes in the load.

Current Limit Current limit is provided for the primary circuit by the internal circuitry of U722. If the ramp voltage at U722 ever reaches 1V, the output drive pulse ends. This shuts Q638 off, so no further voltage is supplied. Thus, the maximum primary current in T1 is limited to approximately 2.5 Amps, which corresponds to a maximum power level of approximately 140 Watts.

As the supply goes into current limit, U615A and Q717 come into play. U722-1 provides an indication of the peak current in T1. This voltage is fed to the inverting input of comparator U615A and compared to a fixed voltage set by divider R616, R615, and R510. R510 is an output power adjustment set so trip point will be approximately 115 Watts. If U722-1 goes high enough to trip U615A-1 low, then C717 will start to charge. If the current limit condition persists long enough for the charge on C717 to reach 700 or 800 mV, U615B trips and Q717 is turned on. This applies the reference voltage from U722-8 directly to U722-3, shutting down the supply and forcing a kick start. The supply will then cycle through kick start, current limit, and shutdown until the problem is corrected. Jumper P720 is included for troubleshooting; its removal will disable the current limit shutdown circuits.

Base Driver and Snubber Q638 is a high (1000V) blocking voltage power transistor. To prevent transistor failure and ensure proper operation, Q638-base must have a large forward current during the on-time and a reverse base-emitter current during turn-off. The pulse from U722-6 turns FET Q648 on and current flows through R746, CR649, and into the base of Q638. The current level is set by R746. Thus Q638 turns on and 320 volts appear across T1, pins 1 and 2. When the pulse from U722-6

ends, Q648 turns off and the collector current of Q638 flows out the base of Q638 through CR648, and quickly turns Q638 off. CR640 forms a Baker Clamp to keep Q638 out of hard saturation and a slow-turn-off. When Q638 is turned off, a voltage spike appears at its collector. A combination of reflected secondary voltages, input voltage, and transformer leakage inductance can combine to produce a spike of over a thousand volts. As this can exceed the voltage rating of Q638, a snubber circuit limits the spike to approximately twice the rectified line voltage. CR500, C500, and the winding on T1, pins 3 and 4, make up the snubber circuit.

Secondary Circuits The secondary circuits all work in the same manner. As mentioned earlier, during the first half of the cycle, CR575 and CR320 are reverse-biased, so there is no current flow.

On the second half of the cycle, when Q638 is shut off, the flyback action reverses the polarities of the secondaries, and the diodes are forward biased. This allows the energy stored within T1 to charge up the capacitors in the secondaries.

The +5 V and the -5 V supplies use LC filters from this point, to further smooth the voltage and eliminate most of the ripple.

Generating 12 Volts

The ± 12 V supplies are generated with a secondary PWM and regulator composed of U200, Q250, T2, and the associated circuits. This secondary PWM is free-running with respect to the primary PWM at a frequency of approximately 60 kHz. The frequency is set by R105 and C105. Q250 is controlled by U200 to switch +5 V and -5 V (10 Volts total) across T2 during the first half of the switching cycle. During the second half of the cycle, the voltage across T2 reverses and CR150 and CR160 turn on, causing a charge to build up on C150 and C152. The voltage on C150 is regulated by U200 to be approximately +14.5 V, and the voltage on C152 will follow at approximately -14.5 V. The 14.5 V is then filtered by L150 and L162, respectively, and applied to the three terminal linear regulators (U150 and U152) to derive the +12 V and -12 V outputs.

R260 senses the current in T2 and feeds it back as a voltage to U200-3. Q200 applies part of the ramp voltage on U200-4 through R125 to U200-3 for better noise immunity.

Q100 is in the voltage feedback path for the +14.5 volts and acts as a level shifter to get the voltage feedback signal to a level referenced at +2.5 V with respect to U200-5. U200-5 is at -5 V with respect to ground. P800 disables the operation of U200 and turns Q250 off. With U200 disabled, the ± 14.5 V outputs will go to ± 5 volts. Jumper P800 is provided for troubleshooting. Its removal will disable the ± 12 V PWM, which may be necessary for diagnosis or repair of the primary portion of the power supply.

Over Voltage Protection

Over voltage protection is provided on the +5 V output by a crowbar circuit composed of Q127, VR120, and R120. If the +5 V output exceeds approximately +5.5 V, VR120 will start to conduct. When VR120 is drawing enough current through R120 to raise SCR Q127 gate voltage above its cathode by approximately 0.7 V, Q127 will turn on. This shorts the +5 V output to ground, forcing the primary circuit into current limit.

Option 1 Board

The SPG 422 Option 1 board contains four separate dual-standard black generators. Each is a separate generator running on a 27 MHz master clock, with PAL and NTSC frame resets to synchronize them and some microprocessor setup information to program them.

Black burst generator <1>, <2>, <3>, and <4>

All black burst generators are identical. The following paragraphs describe black burst generator 3.

Controller PLD. The four black generators are controlled by the microprocessor and the Controller PLD, U2. The Controller PLD takes the video standard selection for each channel and selects and processes the appropriate frame reset

pulse for each generator. The Controller PLD also generates the necessary microprocessor interface signals for each of the Encoder ASICs (U4, U10, U22, and U16).

The standard selection for each channel is loaded into a flip-flop by writing the desired standard selection to the LSB of the 32nd register of the Encoder ASIC data space. This bit selects between the PAL and NTSC frame reset pulses. The Controller PLD then generates a positive output pulse that is one clock cycle wide.

The Encoder ASICs use a slightly different memory timing scheme than the microprocessor, so the Controller PLD generates the modified (READ), (WRITE), ALE, and (CS) pulses.

The Controller PLD also provides a read back register (mapped to register 32 of Black Generator 2). This register is written to and read from by the processor during RAM diagnostics to verify the external data bus connection to the Option 1 board.

Encoder ASIC, Segment Data PROM, and Line and Frame Data PROM. The black generators in the SPG 422 Option 1 store the black signals in component format and generate the composite data with the Encoder ASIC, U4.

Internal counters are reset by an external reset pulse that is derived from the PAL or NTSC frame reset (externally selected by the video standard selected). The reset pulse is 1 clock cycle wide at 27 MHz and will be latched into the counters synchronously by the 27 MHz clock. To accomplish coarse horizontal, vertical, and field timing offsets, the pulse is delayed by an integer number of clock cycles specified by the user.

The SPG 422 actually uses a pair of external memories to store the signals in run-length encoded form: the Segment Data PROM, U6, and the Line and Frame Data PROM, U5.

During the first part of a memory cycle, the H2 line is high. The vertical count, field count, and signal select lines address the frame memory and the line select data is read. When the H2 line goes low, the line select data passes through the multiplexer and is latched. (The two MSBs are also latched separately, forming the bank select address.) This line select data, along with the upper bits of the horizontal count, then addresses the line data memory, and the segment select data is read and latched, along with the line select MSBs. This segment select address, along with the Y/C line and the LSBs of the horizontal count, are latched by the system clock and address the segment data memory. This data is then latched into the Encoder ASIC.

The actual implementation uses a fast RAM to hold the segment data. At power on, the microprocessor reads the segment data (stored in an unused portion of the EPROM) using the ASIC and writes it back to the segment data RAM (using the Encoder ASIC).

The microprocessor interface to the Encoder ASIC is essentially done by a bank of 32 8-bit registers. The Encoder ASIC is mapped into the microprocessor memory space. Five bits of the external address bus, the external READ/(WRITE) line, and an address strobe (BLK2) are used to control the registers. The address strobe, which contains the basic timing information, is generated whenever the microprocessor accesses those memory locations. The strobe is used to generate the Encoder ASIC ALE and (CS) signals. The signals are also decoded and timed by the controller PLD to generate the READ and WRITE strobes.

Configuration data is written to several of the Encoder ASIC internal registers to specify the timing offset, standard, etc. The registers also serve as the porthole through which the segment memories are diagnosed and initialized. At power on, the configuration data is written to the registers and the segment data is read from the EPROM and written to the RAM. Subsequent changes to the signals are just made by changing the configuration data written to the registers.

DAC and Output Filter and Driver. Finally, the over sampled black signal data is fed to the output circuitry. The DAC and output section convert the digital representation of black burst to analog, reconstruct and filter the signal, and buffer it to drive 75 Ω .

Option 2 Board

The Option 2 board produces the additional serial digital test signals that are available when Option 2 is installed in the SPG 422. the circuitry is identical to the Bars generation in the standard instrument.

Serial Test Signal Generation <1>

The Test Signal Generator is a complete generator, requiring only a master clock, (STSGCLK); a synchronous frame reset, (STSS) or (STSR); and some setup information from the microprocessor. On startup, the processor writes the signal configuration information to the generator and downloads the necessary audio and video test signals into RAM.

Horizontal, Vertical, and Field Counters and Decoding PLDs. U9 and U10 are the Horizontal, Vertical, and Field Counters and Decoding PLDs.

The clock and reset drive the counter chain. The counter drives state machines that select the proper test signal RAM address at the correct time in the field.

Timing Reference Signal Generator. U12 is the Timing Reference Signal (TRS) Generator. It gets the appropriate TRS data addresses and loads them into the Serial Bars RAMs so that the data is multiplexed into the video signal.

Serial Test Signal RAM. U13 and U11 are the Serial Bars RAM. Each line of the video signal is stored in sample order, with each video line bottom-justified in memory on 1 kB boundaries. The required video signals are downloaded into the RAM at power on and are not changed during operation unless the video standard is changed.

The the Serial Bars RAMs output, STDD[0..9], is the parallel video signal with the TRS data loaded.

Serial Coprocessor and Outputs <2>

Audio Data RAM. The data in the Audio RAMs is the audio tone formatted in a specific format for AES audio. This data is read out of the Audio RAMs at a particular point in the video data stream to be embedded. The audio data is placed into RAM by the microprocessor through the address, EA[0..14], and data ED[0..7] buses and the various control signals.

Serial Digital Coprocessor. The parallel digital video data with TRS inserted, STSD[0..9], enters U21. The audio data is then multiplexed the data into the data stream from the Audio Data RAMs, U19 and U20. The video data with embedded audio has EDH data is embedded, is scrambled, and exits U21 as the serial digital test signal, SDT[0..9].

SDT[0..9] is serialized by U23 and is then amplified to drive the Serial Test Signal outputs by U22.

Performance Verification

The section consists of checklists and detailed procedures to use in verifying performance parameters and adjusting them to within tolerances.

The order of these procedures has been chosen to minimize changes in equipment setups. Performance parameters may be checked in any order. However, many adjustment setups are interactive. Take care when adjusting individual parameters to ensure that all others remain within specification.

Equipment Required

The following is a list of equipment required for the Performance Verification procedure and Adjustment procedure. While alternate equipment may be used for the Performance Verification, it is not recommended for the Adjustment Procedure. Use of inadequate equipment may result in faulty measurements or adjustments.

NOTE. *Using the equipment in the List of Required Equipment, you can obtain an accuracy ratio of 4:1 or better for warranted measurement specifications, with the following exceptions:*

Serial digital video (bar, black, and test signal) Amplitude is 1.8:1.

SCH phase is 1:1.

Genlock input return loss is 1.25:1.

Table 4-1: List of required equipment

Equipment	Description
Serial digital component waveform monitor	Must display the eye pattern of serial digital component signals. It must also be able to indicate the status of FF and AP CRCs and the presence of at least four channels of embedded audio. Example Tektronix WFM 601E
NTSC waveform monitor/vector-scope	Must be able to genlock to an external source. Equipped with an internal amplitude calibration signal (an internal VAC). Example: Tektronix 1780.
PAL waveform monitor/vector-scope	Must be able to genlock to an external source. Equipped with an internal amplitude calibration signal (an internal VAC). Example: Tektronix 1781.
Oscilloscope	500 MHz bandwidth. Example TDS 654C
75 Ω BNC cables	Example: Tektronix part number 012-0074-00.
75 Ω terminators	Example: Tektronix part number 011-0102-01.
Step attenuator	Must be able to attenuate a signal at least 6 dB and step in 0.5 dB steps. It must also have a 1 GHz bandwidth. Example: 847 Attenuator from KAY Elemetrics Corp.
NTSC/PAL generator	Must be able to turn on/off the burst, vary amplitude, and change its frequency. The SCH phase and the subcarrier frequency should also be variable. Example: Tektronix TG2000 with BG1, AGL1, AVG1 modules
Serial digital demultiplexer	Must be able to check for the presence of embedded audio and have a separate digital audio output. Example: Sony D1-AVD (BXPf-160C).
Digital audio tape recorder	Must be able to accept ASE/EBU digital audio signals and have an output for the VM700T option 40.
VM700T with options 1, 11, and 40 installed	Used to measure serial-audio signals.
Digital frequency counter/timer	Capable of measuring frequencies from 10 to 20 MHz, with accuracy within 100 Hz at 17 MHz. Example: Tegan DC5010 Universal Counter/Timer with WWV external reference
WWV clock reference signal	
75 Ω feed-through terminators (2)	Example: Tektronix part number 011-0103-02.
75/50 Ω adapter	Example: Tektronix AMT75 75/50 Ω Adapter (sets recommended Tektronix oscilloscope TDS 654C for correct vertical amplitude)
Sine wave generator	Capable of providing a 1 to 60 Hz sine wave with high output impedance compared to 75 Ω . Example: Tektronix AFG310 Arbitrary Function Generator

Table 4-1: List of required equipment (cont.)

Equipment	Description
White noise generator	Capable of inserting white noise on a composite video signal with a variable signal to noise ratio of 60 to 10 dB. Example: Noise/Com model no. NC 6107.
271x Spectrum Analyzer	Option 4 (tracking generator) installed
Return Loss Bridge, two 75 Ω precision cables, and two 75 Ω precision terminators	Tektronix part number 015-0149-00 includes all of the required parts.
DMM	Example: Tektronix TX1 True RMS Digital Multimeter
XLR to BNC Impedance Transformer	To 6 MHz. Example: Canare BCJ-XJ-TR 110 to 75 Ω .
Oscilloscope probe (2)	500 MHz., Tektronix part number P6139A

Calibration Data Report

The Calibration Data Report that follows can be used to document instrument performance. In addition, it can be used as a short form Performance Check for those familiar with the Performance Verification Procedure. Only steps that have numeric Performance Requirements are included in this report form. (Some steps have been omitted.)



Calibration Data Report

Instrument: SPG 422 Cal. Date: _____

Serial Number: _____

Certificate Number¹: _____ Technician: _____

Procedure: 071-0035- Revision Date: _____

Step	Operation	Minimum tolerance	Maximum tolerance	Incoming	Outgoing
Serial Digital Video (Bars)					
2	Amplitude	720 mV	800 mV		
3	Rise and Fall Times (20% to 80% amp.)	0.40 ns	1.50 ns		
4	Difference between Rise and Fall Times		0.50 ns		
5	Jitter (over a line)		0.25 ns		
Serial Digital Video (Black)					
2 ²	Amplitude	720 mV	800 mV		
3 ²	Rise and Fall Times (20% to 80% amp.)	0.40 ns	1.50 ns		
4 ²	Difference between Rise and Fall Times		0.50 ns		
5 ²	Jitter (over a line)		0.25 ns		
Serial Digital Video (Test Signal left) Option 2 only					
2 ³	Amplitude	720 mV	800 mV		
3 ³	Rise and Fall Times (20% to 80% amp.)	0.40 ns	1.50 ns		
4 ³	Difference between Rise and Fall Times		0.50 ns		
5 ³	Jitter (over a line)		0.25 ns		

¹ Certificate number is not provided, unless "Certificate of Traceability" is issued.

² The SPG 422 Serial Black output is substituted for the Serial Bars signal in these procedures.

³ The SPG 422 Serial Test Signal output (left) is substituted for the Serial Bars signal in these procedures.

Step	Operation	Minimum tolerance	Maximum tolerance	Incoming	Outgoing
Serial Digital Video (Test Signal right) Option 2 only					
2 ⁴	Amplitude	720 mV	800 mV		
3 ⁴	Rise and Fall Times (20% to 80% amp.)	0.40 ns	1.50 ns		
4 ⁴	Difference between Rise and Fall Times		0.50 ns		
5 ⁴	Jitter (over a line)		0.25 ns		
Serial Digital Audio					
10	Amplitude	900 mV	1100 mV		
11	Rise and Fall Times (10% to 90% amp.)	30 ns	44 ns		
12	Jitter (over a line)		20 ns		
Analog Black Burst (NTSC) Black 1					
13	Blanking Level	-100 mV	+100 mV		
14	Sync Amplitude	-38 IRE	-42 IRE		
15	Burst Amplitude	-38 IRE _{p-p}	-42 IRE _{p-p}		
16	SC/H Phase Accuracy	-5°	+5°		
Analog Black Burst (NTSC) Black 2					
13	Blanking Level	-100 mV	+100 mV		
14	Sync Amplitude	-38 IRE	-42 IRE		
15	Burst Amplitude	-38 IRE _{p-p}	-42 IRE _{p-p}		
16	SC/H Phase Accuracy	-5°	+5°		
Analog Black Burst (NTSC) Black 3 -- Option 1 Only					
13 ⁵	Blanking Level	-100 mV	+100 mV		
14 ⁵	Sync Amplitude	-38 IRE	-42 IRE		
15 ⁵	Burst Amplitude	-38 IRE _{p-p}	-42 IRE _{p-p}		
16 ⁵	SC/H Phase Accuracy	-5°	+5°		
Analog Black Burst (NTSC) Black 4 -- Option 1 Only					
13 ⁶	Blanking Level	-100 mV	+100 mV		
14 ⁶	Sync Amplitude	-38 IRE	-42 IRE		
15 ⁶	Burst Amplitude	-38 IRE _{p-p}	-42 IRE _{p-p}		
16 ⁶	SC/H Phase Accuracy	-5°	+5°		

⁴ The SPG 422 Serial Test Signal output (right) is substituted for the Serial Bars signal in these procedures.

⁵ Option 1 only. Substitute Black 3 for Black 1 in the procedures.

⁶ Option 1 only. Substitute Black 4 for Black 2 in the procedures.

Step	Operation	Minimum tolerance	Maximum tolerance	Incoming	Outgoing
Analog Black Burst (NTSC) Black 5 -- Option 1 Only					
13 ⁷	Blanking Level	-100 mV	+100 mV		
14 ⁷	Sync Amplitude	-38 IRE	-42 IRE		
15 ⁷	Burst Amplitude	-38 IRE _{p-p}	-42 IRE _{p-p}		
16 ⁷	SC/H Phase Accuracy	-5°	+5°		
Analog Black Burst (NTSC) Black 6 -- Option 1 Only					
13 ⁸	Blanking Level	-100 mV	+100 mV		
14 ⁸	Sync Amplitude	-38 IRE	-42 IRE		
15 ⁸	Burst Amplitude	-38 IRE _{p-p}	-42 IRE _{p-p}		
16 ⁸	SC/H Phase Accuracy	-5°	+5°		
Analog Black Burst (PAL) Black 1					
20	Blanking Level	-100 mV	+100 mV		
21	Sync Amplitude	-285 mV	-315 mV		
22	Burst Amplitude	286 mV _{p-p}	315 mV _{p-p}		
23	SC/H Phase Accuracy	-5°	+5°		
Analog Black Burst (PAL) Black 2					
20	Blanking Level	-100 mV	+100 mV		
21	Sync Amplitude	-285 mV	-315 mV		
22	Burst Amplitude	286 mV _{p-p}	315 mV _{p-p}		
23	SC/H Phase Accuracy	-5°	+5°		
Analog Black Burst (PAL) Black 3					
20 ⁹	Blanking Level	-100 mV	+100 mV		
21 ⁹	Sync Amplitude	-285 mV	-315 mV		
22 ⁹	Burst Amplitude	286 mV _{p-p}	315 mV _{p-p}		
23 ⁹	SC/H Phase Accuracy	-5°	+5°		
Analog Black Burst (PAL) Black 4					
20 ¹⁰	Blanking Level	-100 mV	+100 mV		
21 ¹⁰	Sync Amplitude	-285 mV	-315 mV		
22 ¹⁰	Burst Amplitude	286 mV _{p-p}	315 mV _{p-p}		
23 ¹⁰	SC/H Phase Accuracy	-5°	+5°		

⁷ Option 1 only. Substitute Black 5 to the 1780 CH B2 and include it in the procedures.

⁸ Option 1 only. Connect Black 6 to the 1780 CH B3 and include it in the procedures.

⁹ Option 1 only. Substitute Black 3 for Black 1 in the procedures.

¹⁰ Option 1 only. Substitute Black 4 for Black 2 in the procedures.

Step	Operation	Minimum tolerance	Maximum tolerance	Incoming	Outgoing
Analog Black Burst (PAL) Black 5					
20 ¹¹	Blanking Level	-100 mV	+100 mV		
21 ¹¹	Sync Amplitude	-285 mV	-315 mV		
22 ¹¹	Burst Amplitude	286 mV _{p-p}	315 mV _{p-p}		
23 ¹¹	SC/H Phase Accuracy	-5°	+5°		
Analog Black Burst (PAL) Black 6					
20 ¹²	Blanking Level	-100 mV	+100 mV		
21 ¹²	Sync Amplitude	-285 mV	-315 mV		
22 ¹²	Burst Amplitude	286 mV _{p-p}	315 mV _{p-p}		
23 ¹²	SC/H Phase Accuracy	-5°	+5°		
Genlock Functions					
27	Internal Reference Free-Run Frequency	13.499987 MHz	13.500013 MHz		
28	Burst Lock Jitter (SNR >50 dB)		≤0.5°		
29	Pull-in Range	Subcarrier frequency -20 Hz	Subcarrier frequency +20 Hz		
30	Sync Lock Jitter (SNR >50 dB)		≤0.6 nsec (0.75° at 3.58 MHz, 1° at 4.43 MHz.)		
31	Sync Lock Timing Change with Input Sync Amplitude (Over sync amplitude range of nominal value +3 to -3 dB.)		≤2 nsec		
32	Input SC/H Phase Range for Correct Color Framing	-45°	+45°		
33	Burst Lock Phase Change with Input Signal APL (Over input signal APL range of 10% to 90%.)		≤1°		
34	Burst Lock Phase Change with Input Burst Amplitude		≤1°		
35	Burst Lock Phase Change with Input Burst Amplitude (60 Hz hum < 1 V _{p-p} .)		≤1°		
36	Isolation between two 75 Ω terminating inputs		≥60 dB (0 - 5 MHz)		

¹¹ Option 1 only. Connect Black 5 to the 1780 CH B2 and include it in the procedures.

¹² Option 1 only. Connect Black 6 to the 1780 CH B3 and include it in the procedures.

Step	Operation	Minimum tolerance	Maximum tolerance	Incoming	Outgoing
	Return Loss				
38	Genlock Input Return Loss		≥ 40 dB (0 – 5 MHz)		
39	Black 1 Return Loss		≤ 30 dB (0 to 5 MHz)		
39	Black 2 Return Loss		≤ 30 dB (0 to 5 MHz)		

Performance Verification Procedure

Serial Digital — Serial Bars Output

1. Check the EDH

- a. Connect the equipment as shown in Figure 4–1.

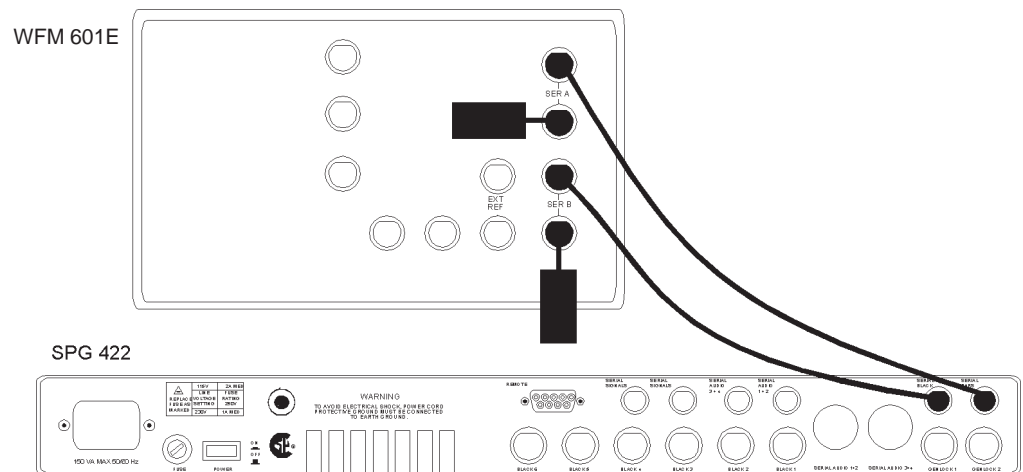

Figure 4–1: Setup to check serial digital video signals

- b. Set the SPG 422 to output any Bars signal with the EDH enabled. (Enable EDH from the Utilities menu.)
 - c. Display CH A on the WFM 601E.
 - d. Press the WFM 601E EDH DET button to bring up the basic status screen.
 - e. Check that the Full Field (FF) and Active Picture (AP) CRC are valid.
 - f. Disable the SPG 422 EDH.
 - g. Check that the Full Field (FF) and Active Picture (AP) CRC are missing.
 - h. Re-enable the SPG 422 EDH.
- #### 2. Amplitude (800 mV \pm 10%)
- a. Connect the equipment as shown in Figure 4–1.
 - b. Set the WFM 601E to display CH A eye pattern.
 - c. Use the WFM 601E voltage cursors to measure the amplitude of the eye pattern. The 5x vertical magnification can be used to aid in accuracy.

- d. Check that the amplitude is 800 mV \pm 80 mV (each major horizontal division of the graticule is 100 mV).

3. Rise and Fall Times (between 0.40 ns and 1.50 ns)

- a. Connect the equipment shown in Figure 4–1.
- b. Set the WFM 601E to display CH A eye pattern.
- c. Use the WFM 601E variable gain control to make the eye pattern amplitude exactly 10 major divisions (1 V).
- d. Place the bottom of the eye pattern on the –0.3 graticule and the top on the 0.7 graticule.
- e. Activate the timing cursors and align the first cursor with the position where the rising edge of the eye pattern intersects the –0.1 graticule (20% point). Align the second cursor with the intersection of the rising edge of the eye pattern and the 0.5 graticule.
- f. Read the Δt from the waveform monitor.
- g. Convert the value from the waveform monitor to the actual rise time using the table below.

Measured Rise Time (ns)	Actual Rise Time (ns)
0.640	0.400
0.710	0.500
0.780	0.600
0.860	0.700
0.900	0.750
0.940	0.800
1.000	0.900
1.100	1.000
1.200	1.100
1.300	1.200
1.400	1.300
1.500	1.400
1.600	1.500

- h. Check that the actual rise time is between 0.400 and 1.500 ns.

- i. Align the first cursor with the position where the falling edge of the eye pattern intersects the 0.5 graticule. Align the second cursor with the intersection of the falling edge of the eye pattern and the -0.1 graticule.
 - j. Read the Δt from the waveform monitor.
 - k. Convert the value from the waveform monitor to the actual rise time using the table.
 - l. Check that the actual fall time is between 0.400 and 1.500 ns.
- 4. Difference between Rise and Fall Times (≤ 0.50 ns)**
- a. Subtract the actual rise time from the actual fall time found in the previous procedure.
 - b. Check that the absolute value is ≤ 0.50 ns.
- 5. Jitter (≤ 0.25 ns)**
- a. Connect the equipment as shown in Figure 4-1.
 - b. Display CH A using the WFM 601E eye pattern display.
 - c. Use the WFM 601E OVERLAY display mode (found in the EYE PATTERN CONFIGure menu).
 - d. Set the WFM 601E to use the 10 Hz jitter filter.
 - e. Set the WFM 601E to x5 vertical gain.
 - f. Use the timing cursors to measure the width of the eye crossings (see Figure 4-2).

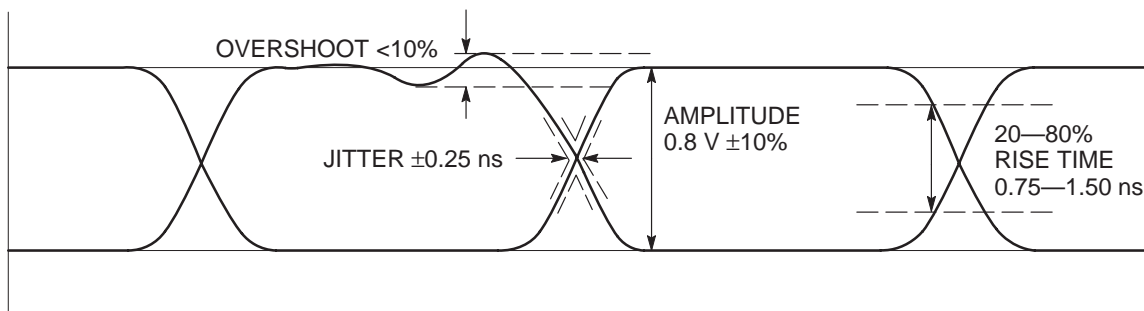

Figure 4-2: Various parts of the serial data stream

- g. **CHECK**— that the Δt of the timing cursors is ≤ 0.25 ns.

6. Check for Presence of Embedded Audio

- a. Connect the equipment as shown in Figure 4–1.
- b. Set the SPG 422 to output any Bars signal with embedded audio enabled. (Enable embedded audio from the Serial Audio menu.)
- c. Press the EDH DET button on the WFM 601E to bring up the basic status screen.
- d. Check that AUDIO 1 2 3 4 is displayed in the upper right hand corner of the display. (Even if all of the audio channels are set to silence, the WFM 601E will recognize the presence of the embedded audio channels.)

7. Embedded Audio Four Channels

- a. Connect the equipment as shown in Figure 4–3.

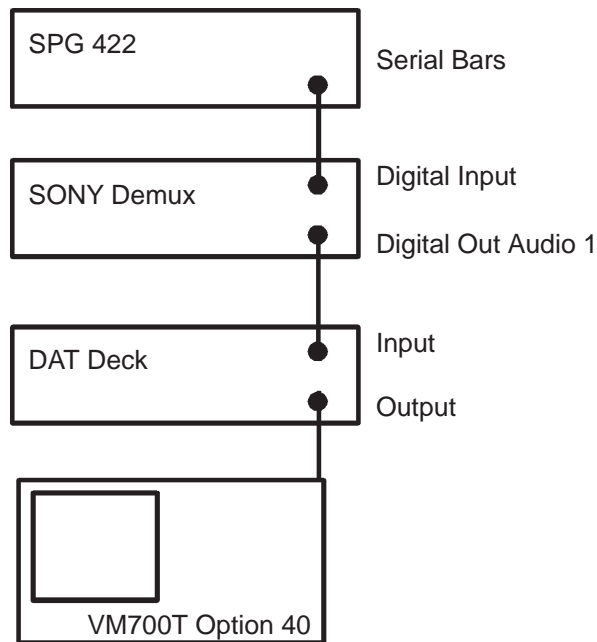

Figure 4-3: Setup required to check for an embedded audio signal

- b. Set all of the SPG 422 audio channels to transmit a 1 kHz audio tone embedded in the serial digital video signal.
- c. Check that the WFM 601E indicates the presence of embedded audio.
- d. Ensure that DIGITAL AUDIO is selected on the Digital Audio Tape (DAT) Recorder.

- e. Check that the LEDs on the DEMUX board light as given in the following list:

PLL Unlock	OFF (not red)
Video Exist	green
Audio Exist (A1 – A4)	all green
Audio Error (A1 – A4)	all off (not red)

- f. Select REC on the DAT. Ensure that the DAT is in PAUSE and the “INPUT” Digital LED is solid red.
- g. Check for a 1 kHz audio tone, using the VM700T.
- h. Set the SPG 422 to transmit 800 Hz on all four channels.
- i. Check that the tone changes to 800 Hz and that the LEDs remain in the correct state.
- j. Set the SPG 422 to transmit silence on channel 1; leave the other channels at 800 Hz.
- k. Check that the AUDIO EXIT LED A1 turns off, while the other three remain on.
- l. Set the SPG 422 to transmit silence on channels 1 and 2. Keep 800 Hz on the other channels.
- m. Check that the AUDIO EXIT LEDs A1 and A2 are off and the other two remain on.
- n. Set the SPG 422 to transmit silence on all channels except 4. Keep 800 Hz on channel 4.
- o. Check that the AUDIO EXIT LEDs A1, A2, and A3 are off and A4 is on.
- p. Set the SPG 422 to transmit silence on all channels.
- q. Check that none of the AUDIO EXIST LEDs light.
- r. Set the SPG 422 to output 1 kHz on all channels.
- s. Check that all of the AUDIO EXIST LEDs light again.

Serial Digital — Serial Black Output

To verify the performance of the Serial Black output, repeat procedures 1, 2, 3, 4, 5, 6, and 7, except replace the Serial Bars output (CH A on the WFM 601E) with the Serial Black output (CH B on the WFM 601E).

Serial Digital — Serial Test Signals Output (Option 2 only)

To verify the performance of the Serial Black output, repeat procedures 1, 2, 3, 4, and 5, except replace the Serial Bars output with the Serial Test Signal output. Repeat these procedures twice, once for each of the two Test Signal outputs (left and right).

Serial Audio

8. Check the Accuracy of the Serial Signals

- a. Connect the equipment as shown in Figure 4-4.

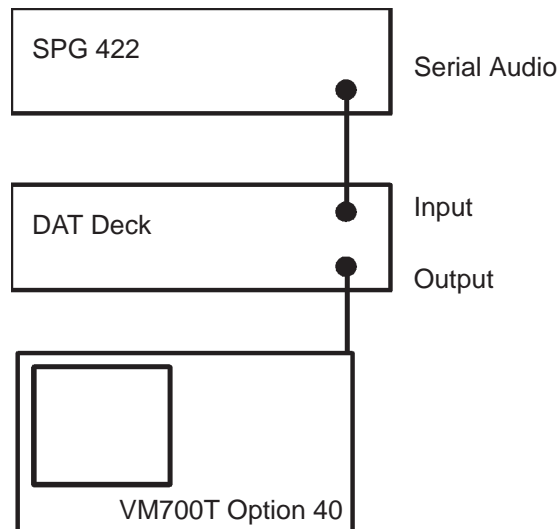

Figure 4-4: Setup to check accuracy of serial audio signals

- b. Set the SPG 422 to output an 800 Hz, -20 dBFS on all four channels.
- c. Turn on the VM700T.
- d. Set the DAT (Digital Audio Tape recorder) to Record and Pause.
- e. Display the audio signal on the VM700T.
- f. Check that frequency is 800 Hz and that the levels for both channels is approximately 2.7 dBu (within 0.1 dBu).
- g. Set the SPG 422 to output 1000 Hz on all channels.
- h. Check that frequency is 1000 Hz and that the levels for both channels is approximately 2.7 dBu (within 0.1 dBu).
- i. Move the cable to SPG 422 audio channels 3+4.
- j. Check that frequency is 1000 Hz and that the levels for both channels is approximately 2.7 dBu (within 0.1 dBu).

- k. Set the SPG 422 to output 800 Hz on all channels.
- l. Check that frequency is 800 Hz and that the levels for both channels is approximately 2.7 dBu (within 0.1 dBu).
- m. Move the cable to SPG 422 BNC audio channels 1+2 using the XLR to BNC adapter.
- n. Check that frequency is 800 Hz and that the levels for both channels is approximately 2.7 dBu (within 0.1 dBu).
- o. Set the SPG 422 to output 1000 Hz on all channels.
- p. Check that frequency is 1000 Hz and that the levels for both channels is approximately 2.7 dBu (within 0.1 dBu).
- q. Move the cable to SPG 422 BNC audio channels 3+4.
- r. Check that frequency is 1000 Hz and that the levels for both channels is approximately 2.7 dBu (within 0.1 dBu).
- s. Set the SPG 422 to output 800 Hz on all channels.
- t. Check that frequency is 800 Hz and that the levels for both channels is approximately 2.7 dBu (within 0.1 dBu).

9. Preparation to use the oscilloscope

- a. Connect the equipment as shown in Figure 4–5.

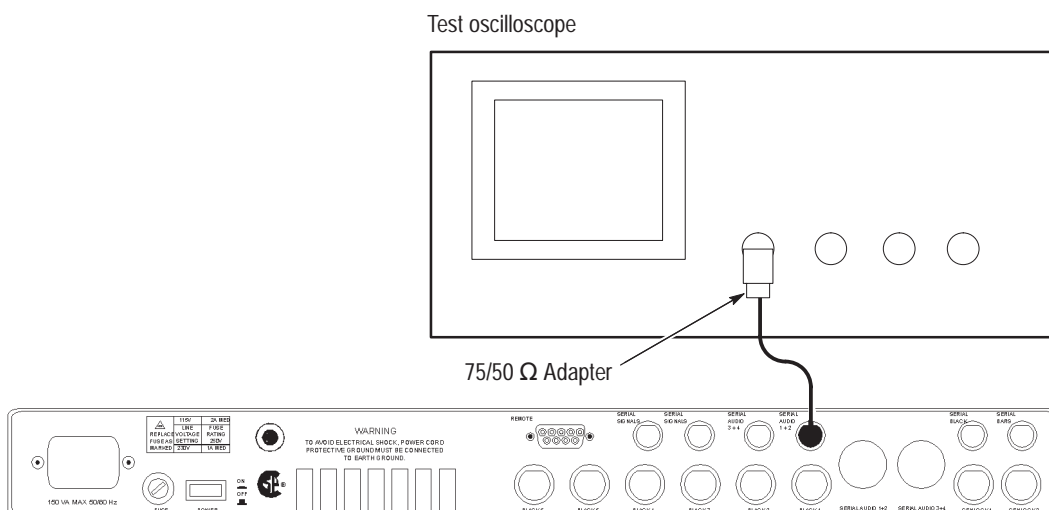

Figure 4–5: Setup to check serial audio signal

- b. Configure the Oscilloscope as follows:

Acquisition	Continuous
Display	Variable Persistent
Vertical	200 mV
Vertical Offset	0 V
Horizontal	1 ns
Horiz Pos	-4 ns
Impedance	50 Ohms
Coupling	DC
BW Limit	Full

Trigger

Trigger	Main
Source	CH1
Level	0 V
Time Holdoff	510 ns
Mode	Auto
Coupling	DC
Slope	+

Measurement

- Rise (S) 10% to 90%
- Fall (S) 10% to 90%
- Amplitude (S)
- Overshoot (S)
- Undershoot (S)
- MID (DC LEVEL)

**10. Serial Audio Amplitude
1 V ±10% into 75 Ω**

- a. Connect the equipment as shown in Figure 4-5. If you use a different 50/75 adapter and TDS oscilloscope from the ones specified in the Equipment List, you must multiply the signal amplitude by 2.23. The specified adapter automatically configures most TDS Oscilloscopes to compensate for the loss through the adapter.
- b. Press the AUTOSET button on the oscilloscope to give a starting point for triggering and adjusting the signal.
- c. Set the display type to variable persistence. This setting should result in the outline of the eye pattern displayed on the screen. The eye pattern should be similar to Figure 4-2.

- d. Check using the oscilloscope cursors (horizontal bars) that the signal amplitude is between 900 and 1100 mV_{p-p}.

11. Rise and Fall Times

30 to 44 ns (10% to 90% amplitude)

- a. Connect the equipment as shown in Figure 6-5.
- b. Set the display type to NORMAL.
- c. From the oscilloscope Measurements menu, select RISE and FALL.
- d. From the oscilloscope Trigger menu, set the slope to +.
- e. Check that the rise time is between 30 and 44 ns.
- f. Change the slope to –, from the Trigger menu.
- g. Check that the fall time is between 30 and 44 ns.

12. Jitter

≤20 ns over the period of a line

- a. Use the horizontal magnification to display the eye pattern crossing.
- b. Use the timing cursors to mark the edges of the eye pattern crossing.
- c. Check that the jitter is less than 20 ns.

Analog Black Burst (NTSC)

13. Blanking Level

0 V ±100 mV

- a. Connect the equipment as shown in Figure 4–6.
- b. Set the TG 2000 BG1 to output NTSC Black Burst signal on the Black 1 and Black 2 outputs.
- c. Display CH A on the waveform monitor.

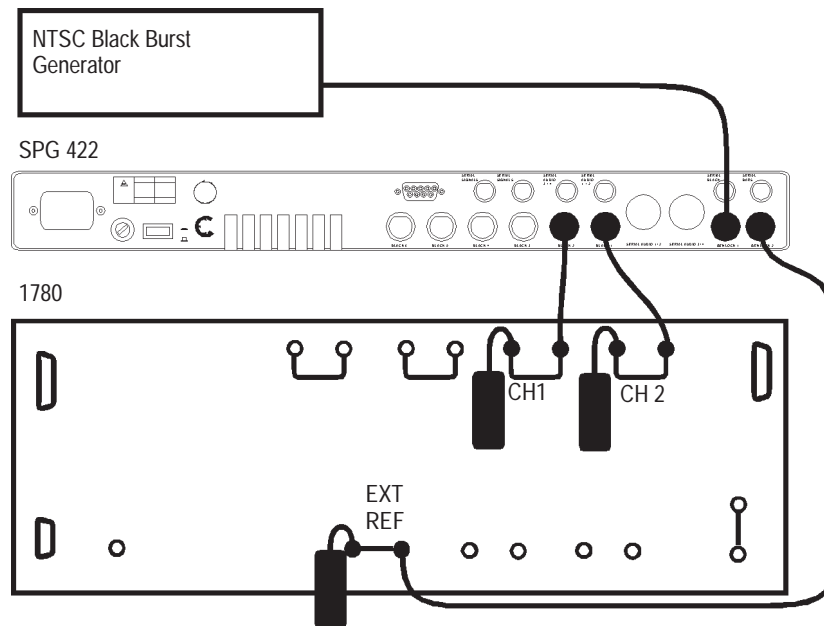

Figure 4-6: Setup to check NTSC analog black outputs

- d. Confirm that any DC restorer feature of the waveform monitor is off.
- e. Toggle the waveform monitor display between DC coupled and ground reference.
- f. Check that the DC level is $0 \text{ mV} \pm 100 \text{ mV}$.
- g. Display CH B1 on the waveform monitor.
- h. Confirm that any DC restorer feature of the waveform monitor is off.
- i. Toggle the waveform monitor display between DC coupled and ground reference.
- j. Check that the DC level is $0 \text{ mV} \pm 100 \text{ mV}$.

14. Sync Amplitude

NTSC: $-40 \text{ IRE} \pm 2 \text{ IRE}$

- a. Connect the equipment as shown in Figure 4-6.
- b. Set the SPG 422 to output NTSC black burst on both Black 1 and Black 2.
- c. Display CH A on the waveform monitor.
- d. Check using the WFM+CAL on the waveform monitor, that the sync amplitude is $-40 \text{ IRE} \pm 2 \text{ IRE}$.

- e. Display CH B1 on the waveform monitor.
- f. Check using the WFM+CAL on the waveform monitor, that the sync amplitude is $-40 \text{ IRE} \pm 2 \text{ IRE}$.

15. Burst Amplitude

NTSC: $40 \text{ IRE}_{p-p} \pm 2 \text{ IRE}$

- a. Connect the equipment as shown in Figure 4–6.
- b. Set the SPG 422 to output NTSC black burst on both Black 1 and Black 2.
- c. Display CH A on the waveform monitor.
- d. Check using the WFM+CAL on the waveform monitor, that the burst amplitude is $-40 \text{ IRE}_{p-p} \pm 2 \text{ IRE}$.
- e. Display CH B1 on the waveform monitor.
- f. Check using the WFM+CAL on the waveform monitor, that the burst amplitude is $-40 \text{ IRE}_{p-p} \pm 2 \text{ IRE}$.

16. SC/H Phase Accuracy ($0^\circ \pm 5^\circ$)

- a. Connect the equipment as shown in Figure 4–6.
- b. Set the SPG 422 to output NTSC black burst on both Black 1 and Black 2.
- c. Display CH A on the waveform monitor.
- d. Put the vectorscope in SCH mode.
- e. Measure the SCH of the black burst using the 1780 special SCH mode.
- f. Check that the SCH is $0^\circ \pm 5^\circ$.
- g. Display CH B1 on the waveform monitor.
- h. Put the vectorscope in SCH mode.
- i. Measure the SCH of the black burst using the 1780 special SCH mode.
- j. Check that the SCH is $0^\circ \pm 5^\circ$.

17. Field Timing Offset Range

± 2 Fields Relative to Genlock

- a. Set up the equipment as shown in Figure 4–6.
- b. Set the SPG 422 to output NTSC black burst with no field timing offset on both Black 1 and Black 2.

- c.** Display CH A (Black 1) on the waveform monitor using three field horizontal timing display and external reference. Note the position of one of the fields. This is the reference field.
- d.** Set the SPG 422 Black 1 field offset to 1 field advance.
- e.** Check that the reference field advances one field from its reference position.
- f.** Set the SPG 422 Black 1 field offset to 2 fields advance.
- g.** Check that the reference field advances two fields from the reference position.
- h.** Set the SPG 422 Black 1 field offset to 1 field delay.
- i.** Check that the reference field delays one field from its reference position.
- j.** Set the SPG 422 Black 1 field offset to 2 fields delay.
- k.** Check that the reference field delays two fields from its reference position.
- l.** Return the SPG 422 Black 1 field delay to 0 fields advance.
- m.** Display CH B1 (Black 2) on the waveform monitor using three field horizontal timing display and external reference. Note the position of one of the fields. This is the reference field.
- n.** Set the SPG 422 Black 2 field offset to 1 field advance.
- o.** Check that the reference field advances one field from its reference position.
- p.** Set the SPG 422 Black 2 field offset to 2 fields advance.
- q.** Check that the reference field advances two fields from the reference position.
- r.** Set the SPG 422 Black 2 field offset to 1 field delay.
- s.** Check that the reference field delays one field from its reference position.
- t.** Set the SPG 422 Black 2 field offset to 2 fields delay.
- u.** Check that the reference field delays two fields from its reference position.
- v.** Return the SPG 422 Black 2 field delay to 0 fields advance.

18. Vertical Timing Offset Range ± 8 lines

NOTE. You may want to shorten this procedure to only include the 8-line advance and delay but the full procedure is more thorough.

- a. Set up the equipment as shown in Figure 6-6.
- b. Set the SPG 422 to output NTSC black burst with no vertical timing offset on both Black 1 and Black 2.
- c. Display CH A on the waveform monitor using one field horizontal display, external reference, and enough horizontal magnification to show eight to ten lines of video.
- d. Use the timing cursor to mark any line. This is the reference line. Note its horizontal position.
- e. Set the SPG 422 Black 1 to one line advance.
- f. Check that the reference line advances one line from its original position.
- g. Set the SPG 422 Black 1 to two lines advance.
- h. Check that the reference line advances two lines from its original position.
- i. Set the SPG 422 Black 1 to three line advance.
- j. Check that the reference line advances three lines from its original position.
- k. Set the SPG 422 Black 1 to four lines advance.
- l. Check that the reference line advances four lines from its original position.
- m. Set the SPG 422 Black 1 to five lines advance.
- n. Check that the reference line advances five lines from its original position.
- o. Set the SPG 422 Black 1 to six lines advance.
- p. Check that the reference line advances six lines from its original position.
- q. Set the SPG 422 Black 1 to 7 lines advance.
- r. Check that the reference line advances seven lines from its original position.

- s. Set the SPG 422 Black 1 to 8 lines advance.
- t. Check that the reference line advances eight lines from its original position.
- u. Set the SPG 422 Black 1 to 1 line delay.
- v. Check that the reference line delays one line from its original position.
- w. Set the SPG 422 Black 1 to 2 lines delay.
- x. Check that the reference line delays two lines from its original position.
- y. Set the SPG 422 Black 1 to 3 line delay.
- z. Check that the reference line delays three lines from its original position.
- aa. Set the SPG 422 Black 1 to 4 lines delay.
- ab. Check that the reference line delays four lines from its original position.
- ac. Set the SPG 422 Black 1 to 5 lines delay.
- ad. Check that the reference line delays five lines from its original position.
- ae. Set the SPG 422 Black 1 to 6 lines delay.
- af. Check that the reference line delays six lines from its original position.
- ag. Set the SPG 422 Black 1 to 7 lines delay.
- ah. Check that the reference line delays seven lines from its original position.
- ai. Set the SPG 422 Black 1 to 8 lines delay.
- aj. Check that the reference line delays eight lines from its original position.
- ak. Return the SPG 422 Black 1 to 0 lines advance.
- al. Display CH B1 (Black 2) using the same waveform monitor setup.
- am. Use the waveform monitor line select to mark a reference line.
- an. Repeat the above procedures for the Black 2 output.

19. Horizontal Timing Offset Range

± 1/2 video line

- a. Set up the equipment as shown in Figure 4–6.
- b. Set the SPG 422 to output NTSC black burst with no horizontal offset on both Black 1 and Black 2.

- c. Display CH A (Black 1) and CH B1 (Black 2) on the waveform monitor in 1-line overlay mode using external reference.
- d. Set the SPG 422 Black 1 to its maximum horizontal advance.
- e. Check that the signal on CH A advances at least $\frac{1}{2}$ line relative to CH B1. (It may be necessary to use the fine horizontal timing control to get the full $\frac{1}{2}$ line advance.)
- f. Set the SPG 422 Black 1 to its maximum horizontal delay.
- g. Check that the signal on CH A delays by at least $\frac{1}{2}$ line relative to CH B1. (It may be necessary to use the fine horizontal control to get the full $\frac{1}{2}$ line delay.)
- h. Return SPG 422 Black 1 to 0 horizontal advance.
- i. Set the SPG 422 Black 2 to its maximum horizontal advance.
- j. Repeat the above procedure for Black 2 (CH B1).
- k. Return SPG 422 Black 2 to 0 horizontal advance.

Analog Black Burst (NTSC Option 1)

- l. Repeat the procedures 12, 14, 15, 16, 17, 18 and 19, except with the following signal changes:

Replace Black 1 and 2 with Black 3 and 4.
Connect Black 5 to CH B2.
Connect Black 6 to CH B3.
Extend all procedures to include Black 5 (CH B2)
and Black 6 (CH B3).

Analog Black Burst (PAL) 20. Blanking Level
0 V ± 100 mV

- a. Connect the equipment as shown in Figure 4–7.

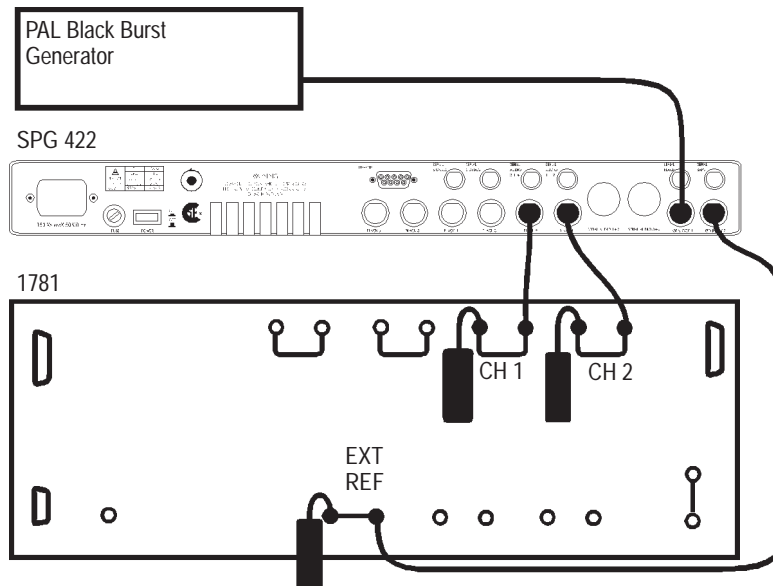

Figure 4–7: Setup to check PAL analog black outputs

- b. Set the TG 2000 BG1 to output a PAL Black signal on the Black 1 and Black 2 outputs.
- c. Display CH A on the 1781 waveform monitor.
- d. Confirm that any DC restorer feature of the waveform monitor is off.
- e. Toggle the display between DC coupled and ground reference.
- f. Check that the DC level is 0 mV ± 100 mV.
- g. Display CH B1 on the waveform monitor.
- h. Confirm that any DC restorer feature of the monitor is off.
- i. Toggle the waveform monitor display between DC coupled and ground reference.
- j. Check that the DC level is 0 mV ± 100 mV.

21. Sync Amplitude**PAL: $-300\text{ mV} \pm 15\text{ mV}$**

- a. Connect the equipment as shown in Figure 4–7.
- b. Set the SPG 422 to output PAL Black Burst on Black 1 and Black 2.
- c. Display CH A on the waveform monitor.
- d. Check using the waveform monitor WFM+CAL, that the sync amplitude is $-300\text{ mV} \pm 15\text{ mV}$.
- e. Display CH B1 on the waveform monitor.
- f. Check using the waveform monitor WFM+CAL that the sync amplitude is $-300\text{ mV} \pm 15\text{ mV}$.

22. Burst Amplitude**PAL: $300\text{ mV}_{\text{p-p}} \pm 15\text{ mV}$**

- a. Connect the equipment as shown in Figure 4–7.
- b. Set the SPG 422 to output PAL Black Burst on Black 1 and Black 2.
- c. Display CH A on the waveform monitor.
- d. Check using the waveform monitor WFM+CAL that the burst amplitude is $300\text{ mV}_{\text{p-p}} \pm 15\text{ mV}$.
- e. Display CH B1 on the waveform monitor.
- f. Check using the waveform monitor WFM+CAL that the burst amplitude is $300\text{ mV}_{\text{p-p}} \pm 15\text{ mV}$.

23. SC/H Phase Accuracy **$0^\circ \pm 5^\circ$**

- a. Connect the equipment as shown in Figure 4–7.
- b. Display CH A on the waveform monitor.
- c. Put the vectorscope in SCH mode.
- d. Measure the SCH of the black burst using the 1781 special SCH mode.
- e. Check that the SCH is $0^\circ \pm 5^\circ$.
- f. Display CH B1 on the waveform monitor.
- g. Put the vectorscope in SCH mode.
- h. Measure the SCH of the black burst using the 1781 special SCH mode.
- i. Check that the SCH is $0^\circ \pm 5^\circ$.

24. Field Timing Offset Range

± 2 Fields Relative to the Genlock Input

- a.** Connect the equipment as shown in Figure 4–7.
- b.** Set the SPG 422 to output PAL black burst with F1L7 and 0 fields advance on both Black 1 and Black 2.
- c.** Display CH A on the waveform monitor using external reference. Use three fields for the horizontal display.
- d.** Note which field contains the F1L7 pulse. This is the reference position.
- e.** Set the SPG 422 Black 1 to 1 field advance.
- f.** Check that the field containing the F1L7 pulse advances one field from the reference position.
- g.** Set the SPG 422 Black 1 to 2 fields advance.
- h.** Check that the field containing the F1L7 pulse advances two fields from the reference position.
- i.** Return the SPG 422 Black 1 to 0 fields advance and take note of the reference position.
- j.** Set the SPG 422 Black 1 to 1 field delay.
- k.** Check that the field containing the F1L7 pulse delays one field from the reference position.
- l.** Set the SPG 422 Black 1 to 2 fields delay.
- m.** Check that the field containing the F1L7 pulse delays two fields from the reference position.
- n.** Return the SPG 422 Black 1 to 0 fields advance.
- o.** Display CH B1 (Black 2) on the waveform monitor using the same waveform monitor setup.
- p.** Repeat the above procedures for the SPG 422 Black 2 output.

25. Vertical Timing Offset Range ± 8 lines

NOTE. You may want to shorten this procedure to only include the 8-line advance and delay but the full procedure is more thorough.

- a. Connect the equipment as shown in Figure 4–7.
- b. Set the SPG 422 to output a PAL black burst with F1L7 pulse and no vertical offset on both Black 1 and Black 2.
- c. Display CH A on the waveform monitor using external reference.
- d. Set the waveform monitor to display a field, then use the horizontal magnifier to display eight to ten lines.
- e. Use the waveform monitor horizontal position control to place the F1L7 pulse on the display.
- f. Use the SPG 422 vertical offset for Black 1 to change the offset to 1 line advance.
- g. Check that the F1L7 advances one line.
- h. Use the SPG 422 vertical offset for Black 1 to change the offset to 2 lines advance.
- i. Check that the F1L7 advances two lines from the original starting point.
- j. Use the SPG 422 vertical offset for Black 1 to change the offset to 3 lines advance.
- k. Check that the F1L7 advances three lines from the original starting point.
- l. Use the SPG 422 vertical offset for Black 1 to change the offset to 4 lines advance.
- m. Check that the F1L7 advances four lines from the original starting point.
- n. Use the SPG 422 vertical offset for Black 1 to change the offset to 5 lines advance.
- o. Check that the F1L7 advances five lines from the original starting point.
- p. Use the SPG 422 vertical offset for Black 1 to change the offset to 6 line advance.
- q. Check that the F1L7 advances six lines from the original starting point.

- r.** Use the SPG 422 vertical offset for Black 1 to change the offset to 7 line advance.
- s.** Check that the FIL7 advances seven lines from the original starting point.
- t.** Use the SPG 422 vertical offset for Black 1 to change the offset to 8 line advance.
- u.** Check that the FIL7 advances eight lines from the original starting point.
- v.** Use the SPG 422 vertical offset for Black 1 to change the offset to 0 line advance. (Back to the original starting point.)
- w.** Use the SPG 422 vertical offset for Black 1 to change the offset to 1 line delay.
- x.** Check that the FIL7 delays one line.
- y.** Use the SPG 422 vertical offset for Black 1 to change the offset to 2 lines delay.
- z.** Check that the FIL7 delays two lines from the original starting point.
- aa.** Use the SPG 422 vertical offset for Black 1 to change the offset to 3 lines delay.
- ab.** Check that the FIL7 delays three lines from the original starting point.
- ac.** Use the SPG 422 vertical offset for Black 1 to change the offset to 4 lines delay.
- ad.** Check that the FIL7 delays four lines from the original starting point.
- ae.** Use the SPG 422 vertical offset for Black 1 to change the offset to 5 lines delay.
- af.** Check that the FIL7 delays five lines from the original starting point.
- ag.** Use the SPG 422 vertical offset for Black 1 to change the offset to 6 lines delay.
- ah.** Check that the FIL7 delays six lines from the original starting point.
- ai.** Use the SPG 422 vertical offset for Black 1 to change the offset to 7 lines delay.
- aj.** Check that the FIL7 delays seven lines from the original starting point.
- ak.** Use the SPG 422 vertical offset for Black 1 to change the offset to 8 line delay.

- al.** Check that the FIL7 delays eight lines from the original starting point.
- am.** Return the delay on Black 1 to 0 lines.
- an.** Display CH B1 on the waveform monitor using the same settings as CH A.
- ao.** Repeat the above procedures for Black 2 (CH B1).

26. Horizontal Timing Offset Range
± 1/2 video line

- a.** Set up the equipment as shown in Figure 4–7.
- b.** Set the SPG 422 to output PAL black burst with no horizontal offset on both Black 1 and Black 2.
- c.** Display CH A and CH B1 on the waveform monitor in 1 line overlay mode using external reference.
- d.** Set the SPG 422 Black 1 to its maximum horizontal advance.
- e.** Check that the CH A signal advances at least ½ line relative to the CH B1 signal. (You may need to use the fine horizontal timing to get to the full ½ line offset.)
- f.** Set the SPG 422 Black 1 to its maximum horizontal delay.
- g.** Check that the CH A signal delays at least ½ line relative to the CH B1 signal. (You may need to use the fine horizontal timing to get to the full ½ line offset.)
- h.** Return the SPG 422 Black 1 horizontal offset to 0.
- i.** Repeat the above procedure for Black 2 (CH B1).

**Analog Black Burst (PAL
Option 1)**

- j.** Repeat the procedures 20, 21, 22, 23, 24, 25, and 26, except with the following signal changes:
 - Replace Black 1 and 2 with Black 3 and 4.
 - Connect Black 5 to CH B2.
 - Connect Black 6 to CH B3.
 - Extend all procedures to include Black 5 (CH B2) and Black 6 (CH B3).

Genlock Functions 27. Internal Reference Free-Run Frequency
13.5 MHz ± 13 Hz

- a. Set up the equipment as shown in Figure 4–8.

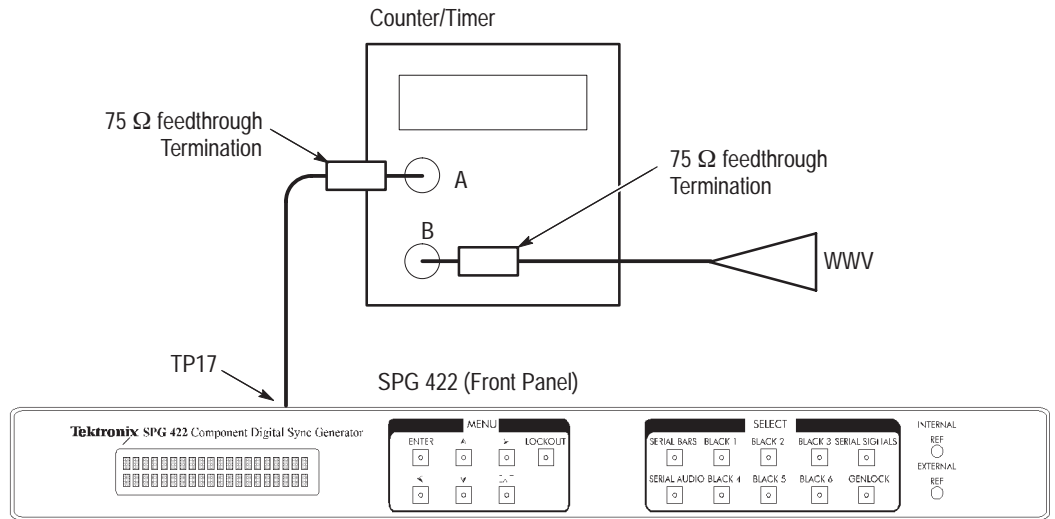

Figure 4–8: Setup to check the oscillator frequency

- b. Connect the probe to TP17.
- c. Check that the counter/timer reads 13.500000 MHz ± 13 Hz.

28. Burst Lock Jitter $\leq 0.5^\circ$ (SNR > 50 dB)

- a. Connect the equipment as shown in Figure 4–9.
- b. Set the SPG 422 to burst lock, genlock loopthrough but do not terminate the Genlock.
- c. Set the step attenuator to 6 dB (0 dB).
- d. Set the TG 2000 BG1 and AVG1 modules to NTSC. You must set each generator.
- e. Set the TG 2000 AVG1 module to output a 0% flat field.
- f. Display CH A on the waveform monitor.

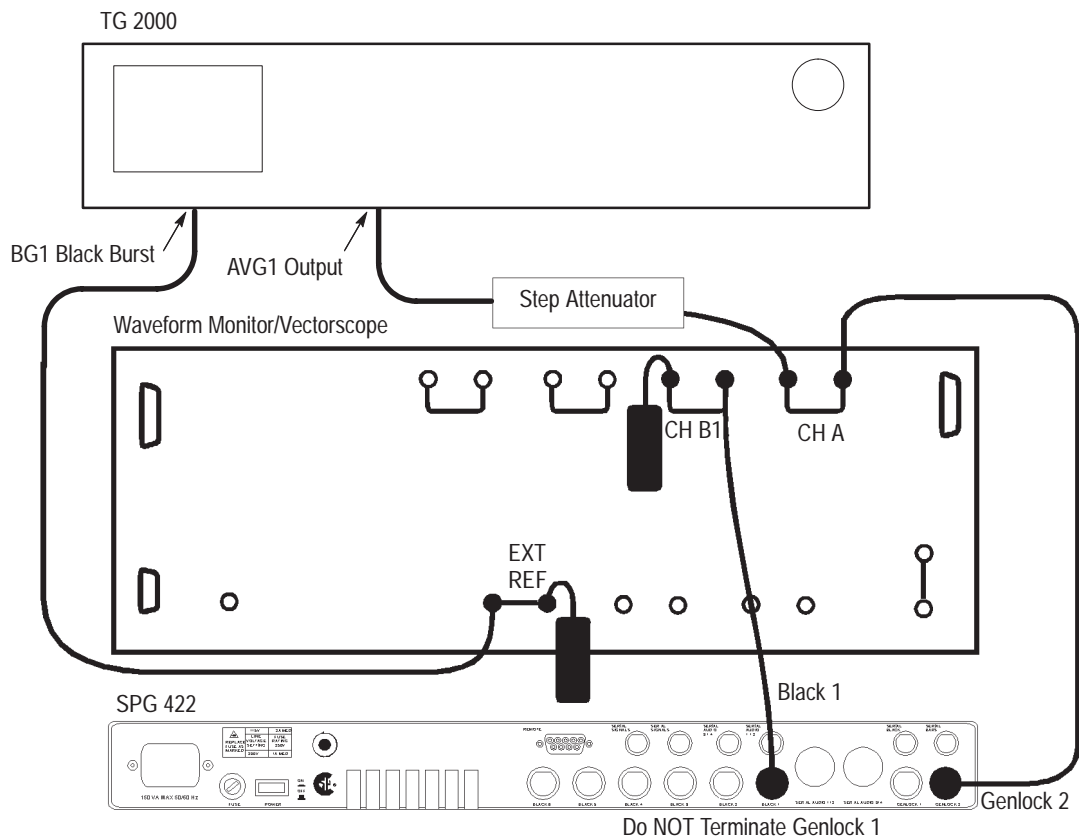

Figure 4–9: Setup to check some genlock functions

- g. Check, using the 1780 waveform monitor, that the genlock input signal has a signal to noise ratio better than 50 dB. (If this signal is not good enough, you will need to find another signal source.)
- h. Display CH B1 on the 1780 vectorscope.
- i. Check for less than 0.5° of jitter.

29. Pull-in Range

Subcarrier Frequency ± 20 Hz

- a. Connect the equipment as shown in Figure 4–9.
- b. Set the SPG 422 to burst lock, genlock loopthrough but do not terminate the loopthrough.
- c. Set the Step Attenuator to 6 dB (actually 0 dB of attenuation).
- d. Set the TG 2000 BG1 and AVG1 modules to NTSC. You must set each generator.
- e. Set the TG 2000 AVG1 module to output a 0% flat field.
- f. Set the TG 2000 AVG1 to provide 20 Hz of subcarrier variation. Select the Active Signal Parameters and select the Subcarrier to adjust it. See the TG 2000/AVG1 manual for detailed instructions to make these settings.
- g. Set the 1780 to display CH A and CH B1 in parade format using external reference.
- h. Set the SPG 422 Genlock to loopthrough.
- i. Set the SPG 422 Black 1 to output a NTSC black burst signal with no delay.
- j. Check that the SPG 422 is genlocked (front-panel External Ref LED is lit).
- k. Set the TG 2000 AVG1 to output the 0% flat field signal with -20 Hz subcarrier variation.
- l. Check that the SPG 422 remains genlocked.
- m. Set the TG 2000 AVG1 to output the 0% flat field signal with $+20$ Hz subcarrier variation.
- n. Check that the SPG 422 remains genlocked.
- o. Return the TG 2000 AVG1 to a normal subcarrier signal.

30. Sync Lock Jitter

≤ 0.6 nsec (0.75° at 3.58 MHz, 1° at 4.43 MHz, SNR >50 dB)

- a. Connect the equipment as shown in Figure 4–9.
- b. Set the SPG 422 to burst lock, genlock loopthrough but do not terminate the loopthrough.
- c. Set the step attenuator to read 6 (0 dB).
- d. Set the TG 2000 AVG1 burst amplitude for the 0% flat field signal to a minimum. Select Signal Parameters for the AVG1 to set the Burst amplitude.
- e. Set the 1780 for External Reference.
- f. Set the SPG 422 for NTSC sync lock, genlock loopthrough.
- g. Display CH B1 on the waveform monitor.
- h. Check using the waveform monitor, that the genlock input signal has a signal to noise (SNR) of better than 50 dB. (If this signal is not good enough, you will need to find another signal source.)
- i. Display CH A on the vectorscope.
- j. Check for less than 2.5° of jitter.

31. Sync Lock Timing Change with Input Sync Amplitude ≤ 2 nsec (Over sync amplitude range of nominal value +3 to –3 dB)

- a. Connect the equipment as shown in Figure 4–9.
- b. Set the SPG 422 for loopthrough, NTSC, sync-lock operation.

NOTE. In order for the step attenuator to provide the range needed for the following test, remove the termination from the waveform monitor input, causing the signal to be increased by 6 dB above nominal levels. Setting the step attenuator to 6, therefore, results in a normal signal level. To attenuate the signal 6 dB, set the step attenuator to read 12. To increase the signal level by 6 dB, set the step attenuator to 0.

- c. Set the step attenuator to read 6 (0 dB).
- d. Check the front-panel menu to see that the SPG 422 sync locks.
- e. Look at the CH B1 vectorscope display to determine the reference phase.
- f. Set the step attenuator to read 3 (+3 dB).
- g. Check the front panel menu to see that the SPG 422 remains sync locked.
- h. the vectorscope for a $< 2^\circ$ color shift on CH B1.

- i. Set the step attenuator to read 9 (–3 dB).
- j. Check the SPG 422 front panel menu to see that the instrument remains sync locked.
- k. Check the vectorscope for a $< 2^\circ$ color shift.
- l. Set the step attenuator to read 6 (0 dB).

**32. Input SC/H Phase Range for Correct Color Framing $0^\circ \pm 45^\circ$
(Will maintain initial color framing until the SC/H error exceeds 120°)**

- a. Connect the equipment as shown in Figure 4–9.
- b. Set the step attenuator to read 6 (0 dB).
- c. Set the TG 2000 AVG1 subcarrier phase to 0° . Select Signal Parameters to adjust the subcarrier phase.
- d. Set the 1780 to display CH A and CH B1 on the vectorscope in overlay mode using external reference.
- e. Rotate the vectorscope display so that CH B1 (the SPG 422 genlock input) is on the 0 line.
- f. Use the SPG 422 Black 1 signal delay to place the CH A vector on the 0 line.
- g. Use the TG 2000 AVG1 subcarrier phase control to vary the phase until the CH A vector jumps color frame. Note the position of the CH B1 vector.
- h. Check that the CH B1 vector changes more than 120 before the genlock changes color frame.
- i. Return the TG 2000 AVG1 subcarrier phase to 0° .

33. Burst Lock Phase Change with Input Signal APL $\leq 1^\circ$ (Over input signal APL range of 10% to 90%)

- a. Connect the equipment as shown in Figure 4–9.
- b. Set the step attenuator to 0 dB.
- c. Set the SPG 422 to terminate Genlock 2.
- d. Set the TG 2000 AVG1 to output a field square wave.
- e. Display CH A on the vectorscope using external reference.
- f. Set the vector on the 0 graticule.
- g. Check that the vector jitter is not more than 1° .

34. Burst Lock Phase Change with Input Burst Amplitude $\leq 1^\circ$ (Will remain locked with SNR > 30 dB)

- a. Connect the equipment as shown in Figure 4–10.
- b. Set the TG 2000 AVG1 to output a 0% flat field.
- c. Set the white noise generator to a minimum amount of inserted noise.
- d. Display CH B1 on the waveform monitor.
- e. Use the waveform monitor to measure the signal to noise ratio of the CH B1 (SPG 422 genlock input) signal.
- f. Set the waveform monitor noise cursor to 30 dB.
- g. Add noise to the signal using the white noise generator until the waveform monitor displays 30 dB of noise. Note the amount of inserted noise from the noise generator. This value will be used later.

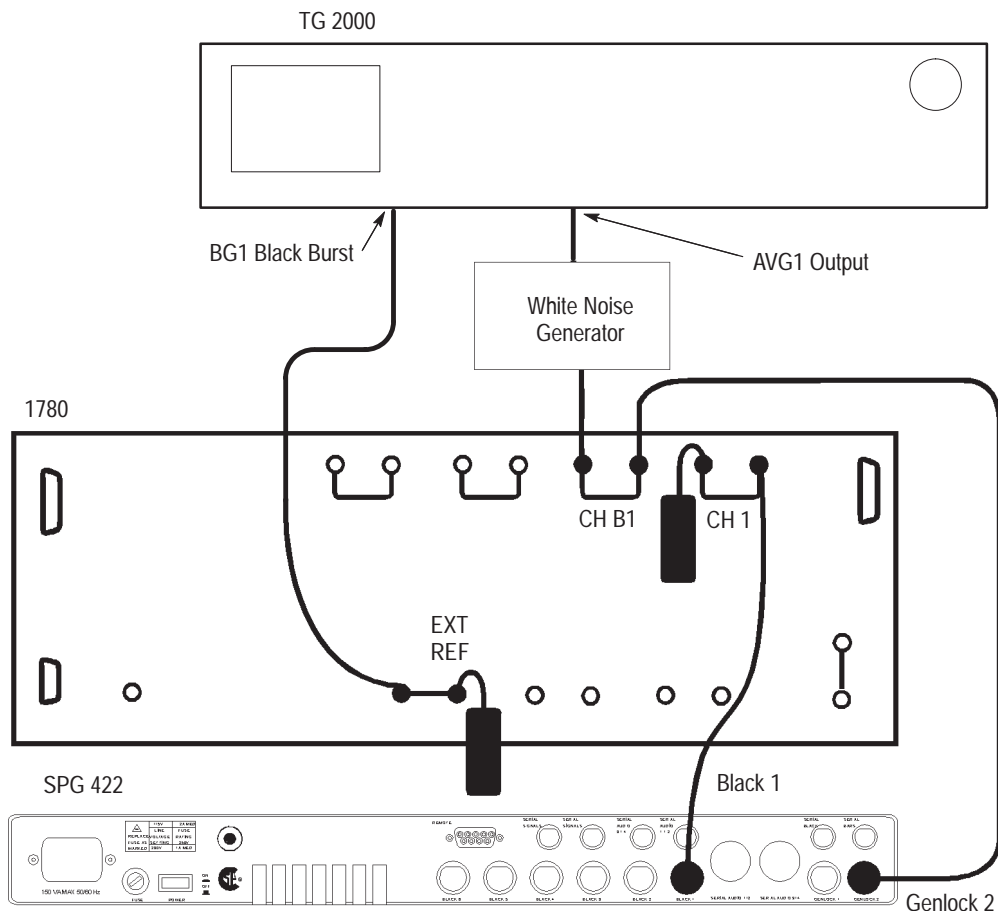

Figure 4–10: Setup to check burst lock phase change

- h.** Return the white noise generator to the minimum amount of noise.
- i.** Set the SPG 422 to burst lock on Genlock 2.
- j.** Check that the SPG 422 is burst locked.
- k.** Display CH A using external reference on the vectorscope. Rotate the subcarrier vector so that it is on the 0° graticule.
- l.** Slowly add noise until 30 dB of noise has been added to the signal.
- m.** Check that the SPG 422 is still burst locked.
- n.** Check that the CH A vector display has not moved more than 1°.

35. Burst Lock Phase Change with Input Burst Amplitude $\leq 1^\circ$ (Will remain locked with 60 Hz hum $< 1 V_{p-p}$)

- a. Connect the equipment as shown in Figure 4–11.

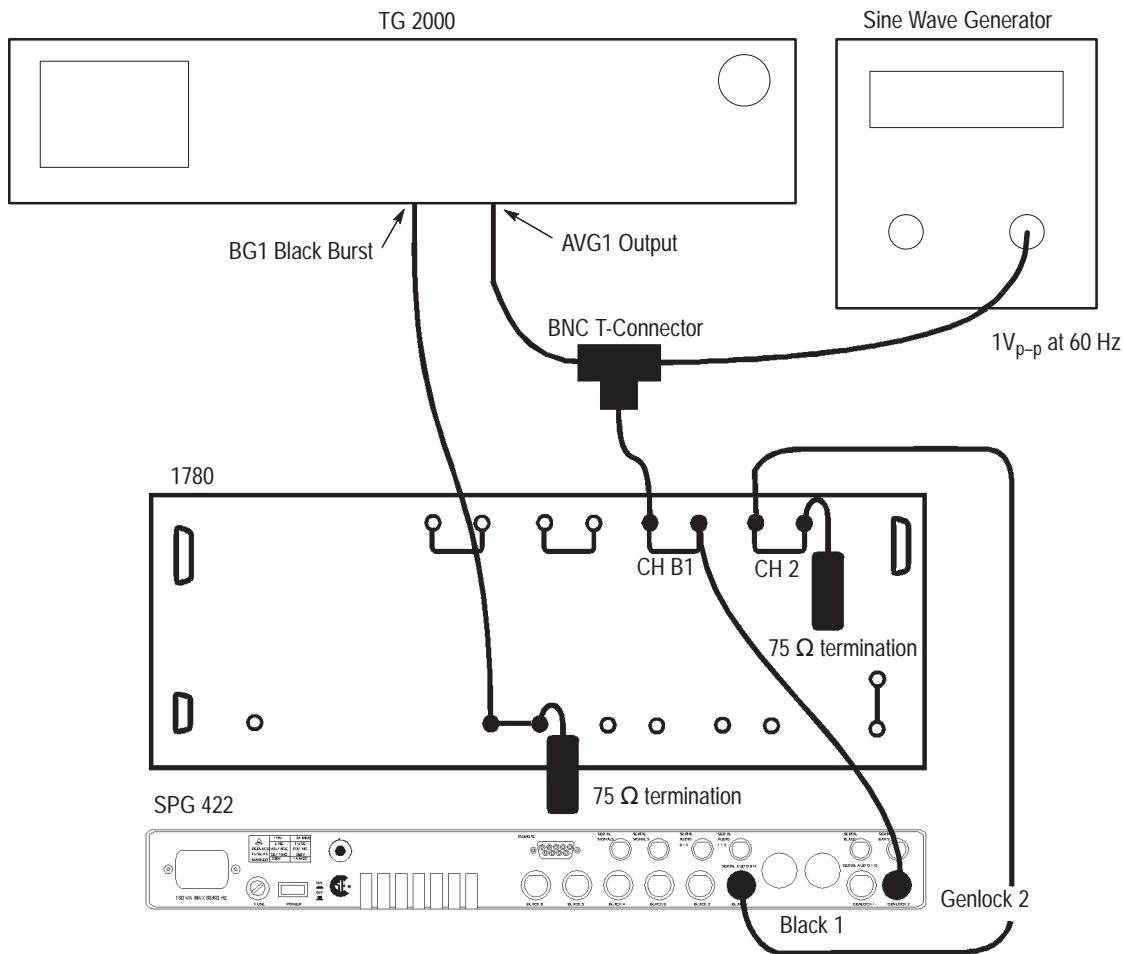

Figure 4–11: Setup to check genlock with hum

- b. Set the TG 2000 AVG1 to output 0% field signal.
- c. Set the sine wave generator to output a $1 V_{p-p}$ 60 Hz signal as shown on CH B1 on the waveform monitor.
- d. Set the SPG 422 to burst lock to genlock input 1.
- e. Check that the SPG 422 is burst locked.
- f. Display CH A on the vectorscope using external reference.

- g. Vary the display to place the vector on the 0° graticule.
- h. Check that the CH A display does not move more than 1° from the 0° reference graticule.

**36. Isolation Between Two 75 Ω Terminating Inputs
≥60 dB (0 – 5 MHz)**

- a. Connect the equipment as shown in Figure 4–12.

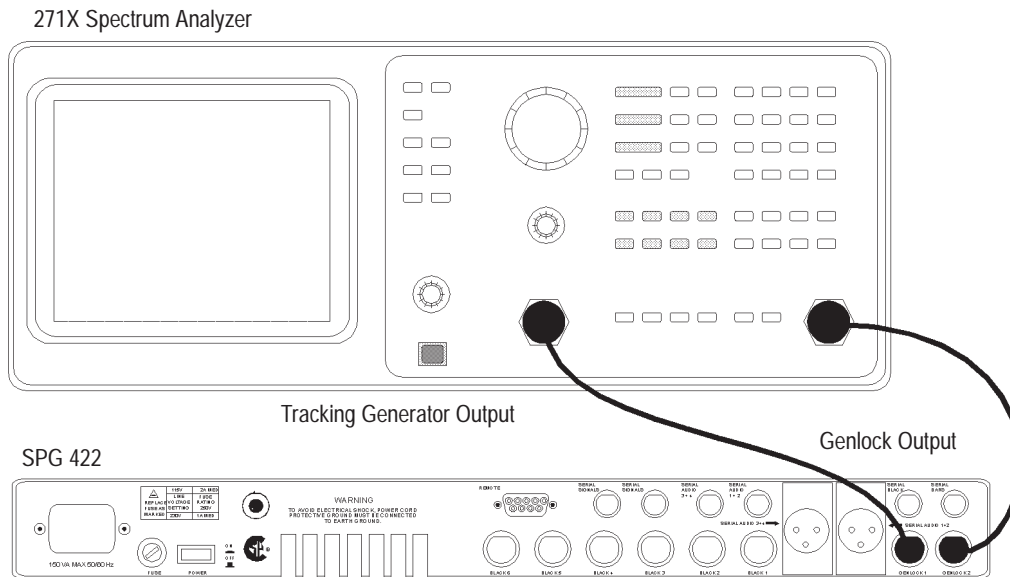

Figure 4–12: Setup to check isolation

- b. Set the SPG 422 for loopthrough genlock.
- c. Set the spectrum analyzer tracking generator to output a 40 dBm (≈ 1 V into 75 Ohms) 5 MHz signal.
- d. Adjust the reference level until the tracking generator signal level is near the top of the spectrum analyzer graticule line.
- e. Set the spectrum analyzer as follows:

Center frequency	5 MHz
Frequency Span/DIV	1 MHz
Resolution BW	AUTO
Trigger	FREE RUN
Display Mode	PEAK
- f. Save the results in the spectrum analyzer register A.

- g. Without altering any spectrum analyzer controls, set the SPG 422 to terminate the Genlock 1 input.
- h. View the spectrum analyzer B register.
- i. Activate the B, C MINUS A feature.
- j. Turn off the A register, and turn on the marker. The B register now contains the difference in dB between the two genlock inputs, and the marker is reading that difference.
- k. Check that the difference is greater than 60 dB from 0 to 5 MHz.
- l. Swap the two genlock input cables.
- m. Without altering any spectrum analyzer controls, set the SPG 422 to terminate the Genlock 2 input.
- n. View the spectrum analyzer B register.
- o. Activate the B, C MINUS A feature.
- p. Turn off the A register, and turn on the marker. The B register now contains the difference in dB between the two genlock inputs, and the marker is reading that difference.
- q. Check that the difference is greater than 60 dB from 0 to 5 MHz.

Return Loss 37. Return Loss Basic Setup

- a. Set the spectrum analyzer as follows:

Center Freq.	5 MHz
Freq Span/DIV	1 MHz
Resolution BW	AUTO
Trigger	FREE RUN
Display Mode	PEAK
- b. Set up the equipment as shown in Figure 4–13.
- c. With the UNKNOWN arm of the return loss bridge open, set the tracking generator output amplitude to $1 V_{p-p}$ (≈ 40 dBm) and the frequency to 5 MHz.
- d. You should see a relatively flat trace.
- e. Adjust the reference signal level until the tracking generator signal level is near the top graticule line. This line represents the return loss reference for the measurement system, including any non-flatness due to the bridge, spectrum analyzer, or tracking generator.

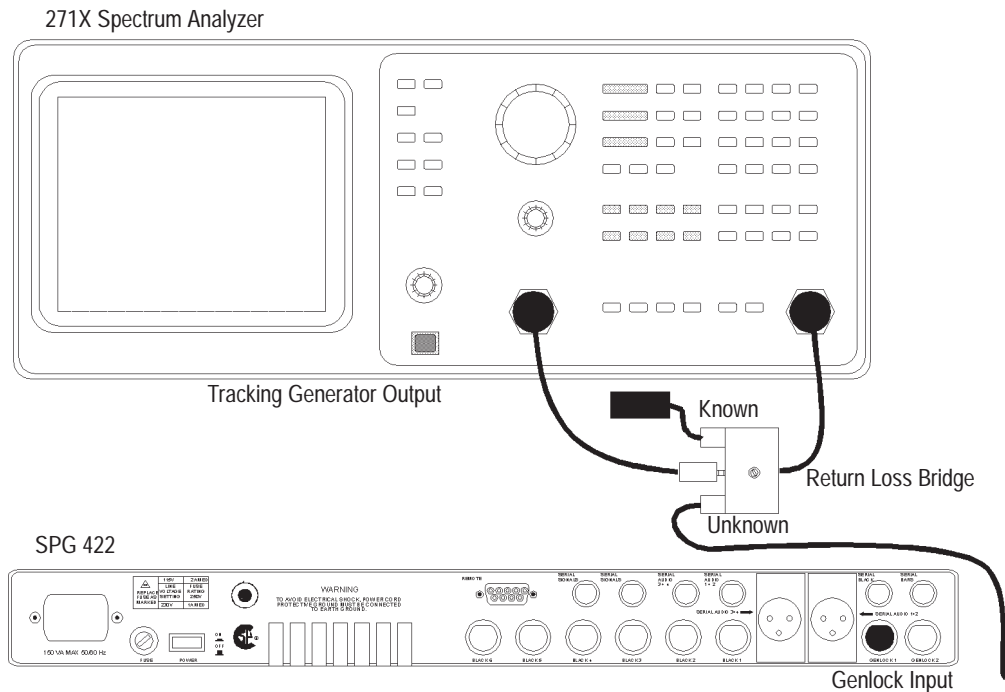

Figure 4-13: Basic setup for return loss checks

- f. Save the results in register A of the spectrum analyzer.

NOTE. All return-loss measurements will be measured in dB from this reference level.

- g. View the B register and connect a precision 75 Ohm termination to the UNKNOWN arm of the return loss bridge. An approximately flat sweep should appear more than 60 dB below the previous trace. This line is the bridge output when it is balanced, and should approach the system noise level. If the difference is not at least 60 dB, troubleshoot your setup.

38. Genlock Input Return Loss
≥40 dB (0 to 5 MHz)

- a. Set the SPG 422 to terminate Genlock 1.
- b. Without altering any controls, remove the resistive load, and connect the SPG 422 Genlock 1 to the UNKNOWN arm of the return loss bridge.
- c. The difference between the A and B traces is the return loss.
- d. Check that the return loss for Genlock 1 is greater than 40 dB.
- e. Set the SPG 422 to terminate Genlock 2.

- f. Without altering any controls, connect the SPG 422 Genlock 2 to the UNKNOWN arm of the return loss bridge.
- g. The difference between the A and B traces is the return loss.
- h. Check that the return loss for Genlock 2 is greater than 40 dB.
- i. Connect the precision terminator to the SPG 422 Genlock 1 input and set the SPG 422 to genlock loopthrough.
- j. The difference between the A and B traces is the return loss.
- k. Check that the return loss for genlock in loopthrough mode is greater than 40 dB.

**39. Black 1 and 2 Return Loss
≤ 30 dB (0 to 5 MHz)**

- a. Connect the UNKNOWN cable to the Black 1 output.
- b. The difference between the A and B traces is the return loss.
- c. Check that the return loss is greater than 30 dB.
- d. Repeat for Black 2 and Black 3 through Black 6 if option 1 is installed.

Adjustment Procedure

The following section provides the user with the procedures required to bring an SPG 422 back into specification.

Summary Adjustment

+5 V Power Supply Adjustment – R415

Fine Phase Filter Adjustment

Signal	Test Point	Null Capacitor	Centering Capacitor
Black 1	TP10	C229	C230
Black 2	TP11	C236	C237
System Black	TP9	C243	C244

Fine Phase Filter Check

Sync Tip Adjustment

Signal	Adjustment	Comments
Black 1	R143	
Black 2	R161	CH B1 on the 1780/1781
Black 3	R14	Option 1 only (connect to CH A)
Black 4	R28	Option 1 only (connect to CH B1)
Black 5	R56	Option 1 only (connect to CH B2)
Black 6	R42	Option 1 only (connect to CH B3)

Black Burst Sync Adjustment

Signal	Adjustment
Black 1	C143
Black 2	C136

Subcarrier and SCH Phase Adjustment for Option 1

Channel	Subcarrier Level	SCH Phase
Black 3	C25	L2
Black 4	C44	L8
Black 5	C82	L20
Black 6	C63	L14

Adjustment Procedure

1. +5 V Power Supply Adjustment (R415)

- a. Connect the line voltage to the SPG 422.
- b. Turn the instrument on.
- c. Connect a probe at TP140 and using a DMM check for +5 V \pm 100 mV.
- d. If the +5 V is out of specification, adjust R415 until it is within specification.

2. Fine Phase Filter Adjustment

- a. Set the Diagnostic Switches (S1) to 31 hex (001100001 closed = 1).
- b. Connect a spectrum analyzer to TP10 (Black 1 on the Digital board) using a 500 Ohm probe.
- c. Center the spectrum analyzer display around the 27 MHz carrier and set the display for 10 dB/division. The carrier should have sidebands spaced at 105 kHz intervals.
- d. Adjust C229 to null the 105 kHz sidebands.
- e. Change the display to 2 dB/division.
- f. Adjust the reference level of the spectrum analyzer to view the carrier.
- g. Adjust C230 for maximum carrier amplitude. (Center the LC resonator around 27 MHz clock.)
- h. Repeat for Black 2 and System Black (Genlock) using the table below as a reference.

Signal	Test Point	Null Capacitor	Centering Capacitor
Black 1	TP10	C229	C230
Black 2	TP11	C236	C237
System Black	TP9	C243	C244

3. Fine Phase Filter Check

- a. Keep the Diagnostic switch (S1) in 31 hex.
- b. Connect TP19 (27 MHz) to channel 1 of the oscilloscope and channel 2 to TP10 (Black 1) using 500 Ω scope probes.
- c. Invert channel 2.
- d. Trigger on the signal from TP19 (channel 1).
- e. Check that the signal from TP10 lags that of TP19 by a nominal 2.2 ns.
- f. If the value of the delay is less than 3 ns or more than 10 ns, repeat the Fine Phase Filter Adjustment (above).
- g. Adjust the centering capacitor for a nominal 6.5 ns delay.
- h. Check Black 2 (TP11) and System Black (TP9) for the same timing.
- i. Return the Diagnostic switches to their default position.

4. Sync Tip Adjustment

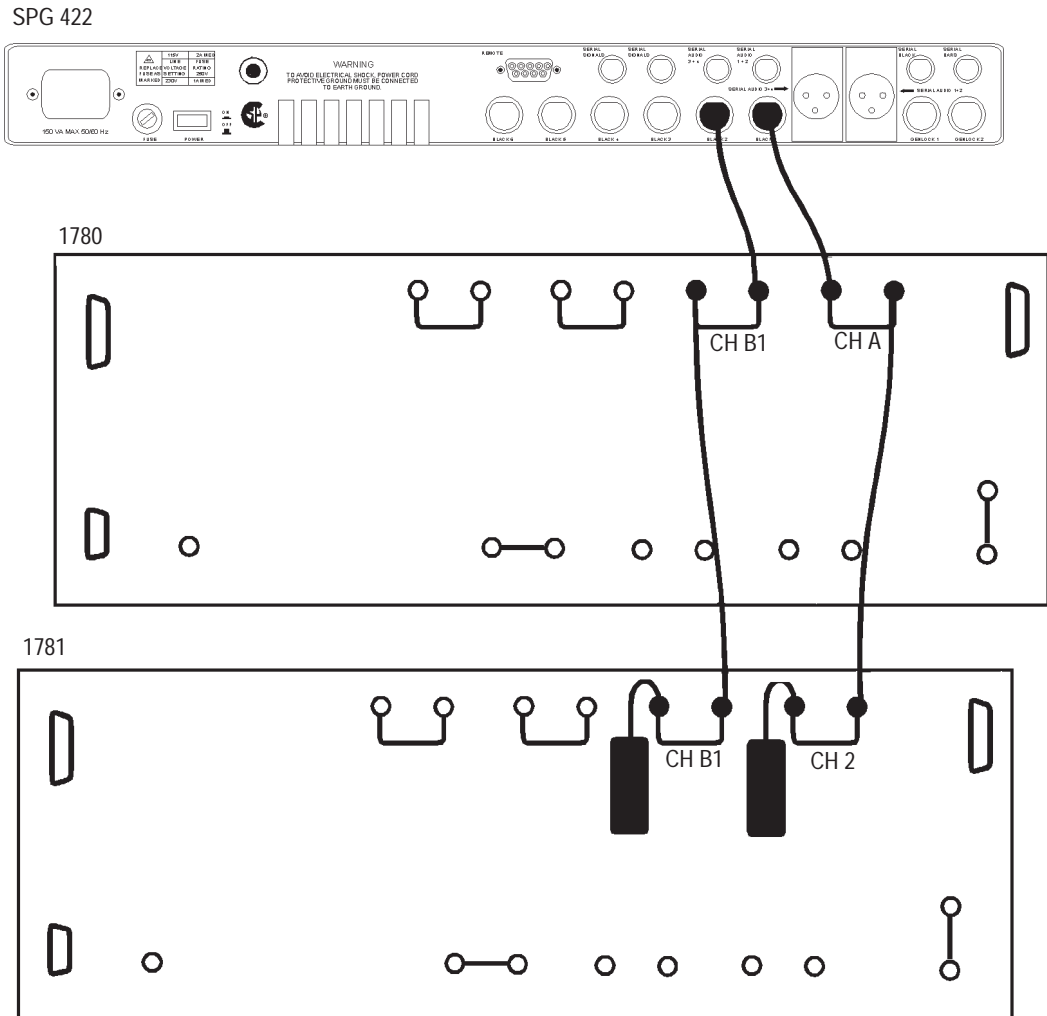

Figure 5-1: Setup for sync tip adjustment

- a. Connect the equipment as shown in Figure 5-1 above.
- b. View Black 1 (CH 1) on the 1781 PAL vectorscope/waveform monitor.
- c. Use the SPG 422 front-panel menu to change the Black 1 output to PAL.
- d. Adjust R143 (gain on the Output board) for proper sync amplitude.
- e. View Black 1 (CH1) on the 1780 NTSC vectorscope/waveform monitor.
- f. Use the SPG 422 front-panel menu to change Black 1 to NTSC.

- g. Check the sync amplitude and readjust R143 as necessary. If R130 requires readjusting, check the PAL version to be sure that it remains within specifications.
- h. Repeat this procedure with the other Black outputs, using the list below to select which potentiometer to adjust and channel to view.

Black 1	R143	
Black 2	R161	CH B1 on the 1780/1781
Black 3	R14	Option 1 only (connect to CH A)
Black 4	R28	Option 1 only (connect to CH B1)
Black 5	R56	Option 1 only (connect to CH B2)
Black 6	R42	Option 1 only (connect to CH B3)

5. Black Burst (Sinx)/x Adjustment

- a. Connect the equipment as shown in Figure 5–1.
- b. Use the SPG 422 front panel to output a PAL signal for Black 1.
- c. View the Black 1 output (CH A) on the 1781 PAL vectorscope/waveform monitor.
- d. Adjust C130 (Sinx)/x on the Output board for proper subcarrier amplitude ($300 \text{ mV}_{\text{p-p}} \pm 15 \text{ mV}$).
- e. Check for proper SCH phase ($0^\circ \pm 5^\circ$), and adjust C130 if necessary.
- f. View the Black 1 output (CH A) on the 1780 NTSC vectorscope/waveform monitor.
- g. Change the Black 1 to output an NTSC signal, using the SPG 422 front panel.
- h. Check that the subcarrier is at its proper level ($40 \text{ IRE}_{\text{p-p}} \pm 2 \text{ IRE}$) and adjust as necessary.
- i. Check that the SCH phase is within specification ($0^\circ \pm 5^\circ$), and adjust if necessary.
- j. Repeat swapping from NTSC to PAL until both subcarrier levels and SCH phases are within specification.
- k. Repeat procedure with the Black 2 output CH B1), adjusting C136.

6. Subcarrier and SCH Phase Adjustment (Option 1 only)

- a. Set up the equipment as shown in Figure 5–1, except connect Black 3 to CH A, Black 4 to CH B1, Black 5 to CH B2, and Black 6 to CH B3.
- b. Use the SPG 422 front-panel menu change the Black 3 output to PAL.
- c. View the Black 3 signal CH A on the 1781 PAL vectorscope/waveform monitor.
- d. Adjust C25 for proper subcarrier amplitude ($300 \text{ mV}_{\text{p-p}} \pm 15 \text{ mV}$) and L2 for zero SCH Phase ($0^\circ \pm 5^\circ$). (Repeat as necessary, because these adjustments interact.)
- e. View the Black 3 signal on the 1780 NTSC vectorscope/waveform monitor.
- f. Use the SPG 422 front-panel menu to change Black 3 to output an NTSC signal.
- g. Check that the subcarrier level is $40 \text{ IRE}_{\text{p-p}} \pm 2 \text{ IRE}$ and the SCH Phase is $0^\circ \pm 5^\circ$.
- h. Adjust C25 and L2 until both NTSC and PAL subcarrier specifications are met.

NOTE. C25 has a gain effect on both NTSC and PAL subcarrier levels, while L2 can be used to trade off gain between NTSC and PAL for their SCH performance.

- i. Repeat procedure with Black 4 through Black 6 output, using the list below:

Channel	Subcarrier Level	SCH Phase
Black 3	C25	L2
Black 4	C44	L8
Black 5	C82	L20
Black 6	C63	L14

Maintenance

This section discusses the options available for servicing the Tektronix SPG 422. It also contains instructions for preventive maintenance, general troubleshooting, and corrective maintenance. If the instrument does not function properly, troubleshooting and corrective measures should be taken immediately to circumvent additional problems.

Service Options

Servicing options include returning the instrument to Tektronix for repair and/or recalibration or major assembly exchange by the customer. Each of these options should be investigated as to which will be the most time efficient and cost effective.

Tektronix maintains service centers around the world to provide quick turn-around repair and recalibration services. When this service is used, even during the warranty period, the instrument should be tagged and repackaged according to the instructions at the end of this section.

Preparation

- Qualified Service Personnel Only
- Read the Safety Summary and the Service Strategy
- Read Operating Basics
- Follow Static Guidelines

Preventive Maintenance

Preventive maintenance consists of cleaning, visual inspection, performance checking, and, if needed, readjustment. The preventive maintenance schedule established for the instrument should be based on the environment in which it is operated and the amount of use. Under average conditions, scheduled preventive maintenance should be performed every 2000 hours of operation.

Service Setups

There is one setup procedure that should only be performed by qualified service personnel, because it requires removal of the instrument top cover. This sets the operation of the rear-panel Remote connector.

Configuring the Remote

RS-232 Operation The instrument is factory-set for RS-232 operation. The remote cable should be connected to J6, labeled RS-232, on the Digital board. See the Reference section of this manual for the RS-232 commands.

Ground-Closure Operation To set the SPG 422 Remote for ground-closure operation, place the remote cable on J9, labeled Parallel on the Digital board. See the Reference section of this manual for how to use the ground-closure commands.

Inspection and Cleaning

Preventive Maintenance consists of cleaning, lubricating, visual inspection, checking performance, and readjusting the SPG 422 on a regular schedule. The inspection and cleaning schedule should be established based on the amount of use and the surrounding environment of the SPG 422. Under average conditions, a preventive maintenance check should be performed at least once a year (severe environment conditions such as high heat, high humidity, or dust may dictate a shorter time interval).

Cleaning The instrument should be cleaned often enough to prevent dust or dirt from accumulating. Dust accumulating in the instrument acts as an insulating blanket, preventing proper cooling, and possibly causing overheating and component breakdown. Under high humidity conditions, accumulated dust can also provide an electrical conduction path.



CAUTION. Avoid the use of chemical cleaning agents that might damage the plastics used in the instrument. Avoid using organic cleaning solutions such as benzene, toluene, xylene, acetone, Freon, or other halogenated hydrocarbon solvents. Use a non-residue type of cleaner, preferably isopropyl alcohol.

Exterior. Remove accumulated dust with a soft cloth or small paint brush. The brush is particularly useful around the connectors and front-panel buttons. Remove hardened dirt with a soft cloth, dampened in a mild detergent and water solution. Do not use abrasive cleaners.

Interior. The best way to remove accumulated dust inside the instrument is to blow it off with dry, low-velocity air. Remove remaining dust with a small paint brush, followed by a soft cloth dampened in a mild detergent and water solution.



CAUTION. Do not allow water to get inside any enclosed assembly or component.

Visual Inspection

Visually inspect the instrument during the preventive maintenance routine for signs of damage, scorched components, and loose or disconnected pin connectors. If you discover heat damaged parts, try to determine the cause of the overheating; otherwise, the damage may repeat.

Periodic checks of the transistors and integrated circuits are not recommended. The best measure of performance is the actual operation of the component in the circuit.

Static-Sensitive Components

This instrument contains electrical components that are susceptible to damage or degradation from static discharge. See Table 6–1 for relative susceptibility of various classes of semiconductors. Higher static discharge voltages than the levels listed in Table 6–1 can degrade the performance and reliability of the semiconductor components. Static voltages of 1 kV to 30 kV are common in unprotected environments.



CAUTION. Static discharge can damage or degrade many semiconductor components.

Table 6–1: Relative susceptibility levels

Semiconductor classes	Relative susceptibility levels
MOS or CMOS microcircuits or discrete or linear microcircuits with MOS inputs (most sensitive)	100 to 500 V
EL, 74F, 74ALS, and 155- P/N parts	200 to 500 V
Schottky signal diodes	250 V
Schottky TTL	500 V
High-frequency bipolar transistors & ICs	400 to 600 V
JFETs	600 to 800 V
Low-frequency linear microcircuits	400 to 1000 V
Low-power Schottky TTL	900 V
TTL (least sensitive)	1200 V

NOTE. *Static discharges of less than 2 kV are seldom felt.*

Observe the following precautions to avoid damage:

1. Minimize handling of static-sensitive components.
2. Transport and store static-sensitive components or assemblies in their original containers or on non-conductive surfaces.
3. Discharge the static voltage from your body by wearing a grounded wrist strap while handling these components. Service static-sensitive components or assemblies only at a static-free workstation by qualified personnel. If soldering is involved, use a soldering iron connected to earth ground and special anti-static desoldering tools.
4. Avoid handling components in areas that have a floor or work surface covering capable of generating a static charge. Carpeted floors should be sprayed to reduce static problems. Also nothing capable of generating or holding a static charge should be allowed on the work-station surface.
5. Keep the component leads shorted together whenever possible.
6. Pick up the components by the body, never by the leads.
7. Do not slide the components over any surface.
8. Use a soldering iron that is connected to earth ground.
9. Use only special anti-static, suction, or wick-type desoldering tools.

Performance Verification and Readjustments

Instrument performance should be checked after each 2000 hours of operation, or every 12 months. This will help to ensure maximum performance and assist in locating defects that may not be apparent during regular operation. The Performance Verification and Adjustment Procedures are included in this manual.

Corrective Maintenance

The following procedure is designed to assist in isolating problems, which in turn expedites repairs and minimizes down time. There are no specific troubleshooting procedures for this instrument because it is a very simple instrument.

General Troubleshooting Procedures

Ensure that the malfunction exists in the instrument. This is done by making sure that the instrument is operating as intended by Tektronix (see Operating Instructions), and by checking that a malfunction has not occurred before the signal entered the SPG 422.

Determine and evaluate all trouble symptoms. This is accomplished by isolating the problem to a general area, such as an assembly. The block diagram and the Theory of Operation are valuable aids in signal tracing.



CAUTION. Use extreme care when probing with meter leads or probes. The components are very dense and there is only limited access within the instrument. The inadvertent movement of leads or a probe could cause a short circuit or transient voltages capable of destroying components.

Determine the nature of the problem. Attempt to make the determination of whether the instrument is out of calibration or if there has been a component failure. Once the type of failure has been determined, proceed on to identify the functional area most likely at fault.

Visually inspect the suspect assembly for obvious defects. Most commonly these will be broken or loose components, improperly seated components, overheated or burned components, chafed insulation, etc. Repair or replace all obvious defects. In the case of overheated components, determine the cause of overheating and correct the cause before re-applying power.

Use successive electrical checks to locate the source of the problem. The primary tool for the problem isolation is the oscilloscope. Use the Performance Verification procedure to determine if a circuit is operating within specifications. At times, it may be necessary to change a calibration adjustment to determine if a circuit is operational, but since this can destroy instrument calibration, care should be exercised. Before changing an adjustment, note its position so that it can be returned to its original setting.

Determine the extent of the repair. If the necessary repair is complex, it may be advisable to contact your local Tektronix field office or representative before continuing. Removal and replacement procedures for the assemblies can be found in this section.

Tektronix Service Offerings

Tektronix maintains a service organization that can provide a number of services to assist in maintaining instrument operation at its specified levels. They range from complete repair and adjustment, at a convenient location, to supplying replacement parts. In addition, there are training programs that are available for service technicians.

NOTE. *When considering which service offerings best suit the current need, remember that Tektronix provides a limited parts and service warranty for all its products. No customer repairs should be attempted during the instrument warranty period.*

Service Training

Tektronix provides service training in a number of programs. In addition to classes held at our Beaverton campus, special classes at convenient locations can be arranged. To find out more about service training programs, contact your local Tektronix field office or representative. US customers can call our service organization directly using 1-800-TEK-WIDE (835-9433) and ask for "Service Training". The 800 number is a 24-hour service, but service training specialists are only available between 8 am and 4 pm pacific coast time.

Field Service Centers

Tektronix maintains service centers worldwide. These centers provide repair and calibration services for Tektronix instruments. They can be contacted through your Tektronix field office or representative. In addition, US and Canadian customers can call 1-800-TEK-WIDE (835-9433) for assistance in contacting their nearest service center. Not all service centers are equipped to repair or calibrate all instruments; be ready to give the operator the instrument type and operating options when calling for assistance.

Module Exchange

The module exchange program provides an easily accessible means of returning an instrument to operational status. The defective module is exchanged for a calibrated module at a cost less than the new module price. The process begins by contacting one of the module exchange centers. They can be contacted through your Tektronix field office or representative. In addition, US customers can call 1-800-TEK-WIDE (835-9433) for assistance in contacting the Television Board Exchange Center. The center will provide information on the cost of the module and returning the failed module.

NOTE. *Circuit boards that are damaged due to mishandling or containing modifications not originated by Tektronix are not acceptable for the exchange program.*

When calling to arrange for a circuit board exchange it is essential that you have some information ready to relay to our technician. The instrument type and serial number, along with installed options are absolutely essential. In addition, the Assembly number (A??) and the 9-digit circuit board part number (67?-????-??) will help ensure that you are getting a direct replacement. Finally, if you know or are able to provide the software version number it will further ensure that the circuit board you receive will return instrument performance to what it was before the failure occurred.

The following paragraphs are intended to assist in ordering the exact circuit board replacement. Note that this information is important whether you are ordering a circuit board from the Module Exchange Center or as a new replacement part from Tektronix.

Circuit board assembly number	Assembly name
Front Panel	A1
Digital	A2
Output	A3
EMI Filter	A7
Option 1	A5
Option 2	A6
Power	A4

Circuit Board Assembly Number. This is the number used in the Replaceable Electric Parts List, Circuit Board Illustrations, and on the schematic diagrams to identify the assembly.

Assembly Name. The actual name applied to the circuit board. It will usually be related to the function of the assembly. Use this number to look up the Tektronix part number.

First Seven Digits of the Part Number. These digits make up the general part number. They are often the same for several members of the same instrument family. Always look up this number in the part list. Be sure that it is for the serial number of your instrument. See the Replaceable Electrical Parts list Serial Number/Assembly Effective/Discontinued column for the range in which your instrument serial number falls.

Part Number Suffix. This portion of the part number often varies between members of the same family to denote various types or because the circuit board contains factory-modified circuitry. Always look up this number in the parts list. Be sure that it is for your instrument serial number. See the Replaceable Electrical Parts list Serial Number/Assembly Effective/Discontinued column for the range in which your instrument serial number falls.

Having the pieces of information from the Replaceable Parts List, plus the instrument type, serial number, and software version number (if applicable) ensures that you will receive the module required to return the instrument to complete operation.

Factory Replacement Parts

Replacement parts are available through the local Tektronix field office or representative. However, many common electric parts are available through local sources. Using a local source, where possible, will eliminate shipping delays.

Changes to Tektronix instruments are sometimes made to accommodate improved components, as they become available, and to improve circuit performance. Therefore, it is important to include the following information when ordering parts:

1. Part Number
2. Instrument Type or Number
3. Serial Number
4. Modification or Option Number (if applicable)

Etched Circuit Boards

The instrument consists of etched circuit boards. All of the circuit boards are designed as assemblies. Each assembly has an alphanumeric designation. These assemblies are listed at the beginning of the Replaceable Electrical Parts list of this manual.

Troubleshooting Aids

There are several troubleshooting aids that the SPG 422 provides. These include: Diagnostic LEDs, the diagnostics from the front panel, and the S1 diagnostic switch on the Digital board.

Diagnostic LEDs There are several Diagnostic LEDs on the circuit boards that only light in the event of a problem within a given circuit. See Table 6–2 below for the LEDs and what problems they indicate.

Table 6–2: Diagnostic LEDs

Board	LED	Indication	Solution
Digital	DS1	Oven Under Temperature	Wait at least twenty minutes after power-on to assure that the crystal is warm and stable. This LED could be on by itself or all of the other LEDs could also be on.
Digital	DS4	13.5 Loop Unlocked	If on in conjunction with DS1, Oven Under Temperature LED, just wait until the crystal warms up then both LEDs should turn off. Otherwise, the crystal could be out of the range of the 13.5 PLL. If you are using internal genlock, this LED should never be on.
Digital	DS2	108 Loop Unlocked	The 108 PLL is outside of its 50 kHz pull-in range. If DS1 and DS4 are also on, wait for the crystal to warm up before continuing troubleshooting. Otherwise, there is a problem in the 108 MHz oscillator circuit.
Digital	DS3	6.144 Loop Unlocked	The 6.144 MHz audio clock is unlocked. There is a problem in the 6.144 MHz oscillator circuit or data is not properly loaded in the Ado Altera part.

Front-Panel Diagnostics These are explained completely in the user manual. Please see the discussion of the front-panel diagnostics in that manual.

S1 Diagnostic Switch These diagnostics are in addition to the front-panel diagnostics and can help narrow down a problem.

There are three types of diagnostics, including:

- C. Diagnostic runs continuously until switch is moved to new position
- U. User feedback only (using LEDs, LCD display, scope display, etc.)
- P. Processor feedback (using LCD display or RS-232)

Table 6–3: Diagnostic switch

Code (S1) 12345678	Diagnostic name	Function	Type
00000000		Default position, no diagnostics	
X0000000	EPROM diagnostic	<p>Calculate and check EPROM checksums</p> <p>This diagnostic tests the state of U10 and U11 by performing a checksum. Since the complement of the checksum is stored at the end of each device, the overall checksum for each device should be 0.</p> <p>The Checksum calculation for U10 is in the range 0xC0000–0xFDFFF. This excludes 8K bytes at the upper part of U10 for two reasons. The first is that 0xFFFF00–0xFFFFF is reserved for internal CPU registers, and second that the TdRem (Turbo Debugger Remote) requires address space 0xFFE00–0xFFFFF. The complement of the checksum value is calculated and stored at location 0xFDFFF.</p> <p>The Checksum calculation for U11 is in the range 0x00000–0x3FFFF. The complement of the checksum is stored at 0x3FFFF.</p>	C,U,P
X000000X	RAM diagnostic	<p>Read/write test of all RAMs</p> <p>This routine tests:</p> <ol style="list-style-type: none"> 1) Serial Color Bar RAM (U26, U27) 2) Serial Color Bar Coprocessor RAM (U42, U43) 3) Read back registers on the Option 1 board 4) Option 1 Black Signal video RAM (U6, U12, U18, U24) 5) Option 2 Serial Test Signal video RAM (U13, U11) 6) Serial Test Signal Coprocessor RAM (U19, U20) 	C,U,P
X00000X0	NVRAM diagnostic and initialize	<p>Test and initialize NVRAM</p> <p>This routine tests reading and writing of the NVRAM. It then uses the return code to notify the user of the test results. If the tests are successful, the NVRAM is then initialized to factory defaults.</p> <p>If this routine is called from the front-panel diagnostics menu or by the diagnostic switches, the user must press the front-panel ENTER key to execute the NVRAM test and initialization to prevent accidental destruction of the stored settings.</p>	C,U,P
X00000XX	Port diagnostic	This routine walks through the decoded addresses to allow the user to troubleshoot address decoder problems. This routine confuses the processor system, so it reboots when exiting the routine.	C,U

Table 6–3: Diagnostic switch (cont.)

Code (S1) 12345678	Diagnostic name	Function	Type
X0000X00	RS–232 loopback	<p>Loopback Test — Sends, receives, and verifies characters using the RS-232 port.</p> <p>The Loopback Test writes a test string to the RS-232 transmitter and expects to receive the same string back in the receiver within approximately one second. If the string is not received or if it is not correct, an error is reported.</p>	C,U,P
X0000X0X	Switch/LED test	<p>Reads switches and lights their LEDs</p> <p>This routine allows the user to test front-panel LEDs and switches by manually pressing the switches and verifying that the corresponding LED comes on.</p>	C,U
X0000XX0	LCD test	<p>LCD and LCD memory test</p> <p>This routine writes data patterns to the LCD display and its memories and then verifies each result. If a readback compare is in error the routine prematurely returns with an error number. At the end of the routine the backlight blinks indicating that all tests have passed.</p> <p>The error number is NOT programmed to display anything at this time. However if no errors have occurred, then the routine will not have quit early and the Backlight will blink.</p>	C,U
X0000XXX	DAC ramp diagnostic	<p>Outputs ramp from LCD contrast DAC</p> <p>This diagnostic allows the user to test the DAC by verifying that the DAC is generating a ramp. This can be used to verify that the oscillator test voltage TEST_COR varies between 3.24 V and 7.4 V. Test_Cor is routed through an active switch to the Oscillator oven as the Tune voltage. See the VCO diagnostic for oscillator adjustment.</p> <p>The ramp to the contrast control is too fast to notice any contrast changes on the display. The front-panel contrast control adjustment should be used to check contrast.</p>	C,U
X000X000	Parallel remote diagnostic	<p>Reads from the parallel remote and writes to the display</p> <p>This routine allows the user to test the parallel ground-closure remote by verifying that the binary contents of the parallel remote switches are written to the display.</p>	C,U,P

Table 6–3: Diagnostic switch (cont.)

Code (S1) 12345678	Diagnostic name	Function	Type
XoooXooX	Serial output clock	Serial output clock diagnostics This diagnostic forces the GVG serializer CLK/(VID) lines high to make them output a 270 MHz clock instead of serial digital video. This is to help in troubleshooting the instrument only. The problem is that if there is a problem and the output goes away, it could be that the serializer is not working or it could be that its data inputs have stopped. Either way, there is no serializer output to examine. It should also be easier to measure the jitter on the clock output.	C,U
XoooXoXo	VCO diagnostic	Sends test voltage to VCO This diagnostic uses the LCD contrast DAC to drive the VCO correction voltage to allow the user to test the oscillator pull range from the front panel. This is to verify specifications and help troubleshooting the instrument only. Wait for a button to be pressed. If LEFT_BUTTON or RIGHT_BUTTON is selected to update "value" and write the test value to the contrast DAC.	C,U
XoooXoXX	Genlock FPGA diagnostics	This routine downloads a new configuration file to the genlock controller PLD(U82) and then test the reading/writing of the internal registers.	C,P
XoooXXoo	Genlock calibration diagnostics	This diagnostic downloads a set of values to the FPGA (U82) for calibration. The Genlock IC (U82) contains 16 addresses beginning at "GNLK_ADDR" address. The values downloaded are: Reg: 0 1 2 3 8 9 Value (hex) : 80 3F 3F 0 3F 0	C, U, P
oXooooo	Lockout	Enables (Open) / Disables (Closed) Lockout Timing Lockout timing disables the keyboard after 5 minutes, when enabled by setting segment 2 open. This prevents inadvertent keyboard selections from being made. Lockout timing is disabled (infinite delay) when segment 2 is closed. The Lockout button may still be used to disable the keyboard, and power-up will initially enable the lockout.	

Repackaging Instructions

Repackage the instrument according to these instructions.

Identification Tag

If the instrument is to be shipped to Tektronix Service Center for service or repair, attach a tag to the instrument showing:

1. Owner (with complete address) and the name of the person at your firm that can be contacted.
2. Instrument serial number and a description of the service required.

Repackaging for Shipment

Repackage the instrument in the original manner to provide adequate protection. If the original packaging is not available or is unfit for use, repackage the instrument as follows:

1. Obtain a corrugated cardboard carton whose inside dimensions are at least six inches greater than the dimensions of the instrument to allow room for cushioning. The shipping carton should have a test strength of at least 275 pounds.
2. Surround the instrument with polyethylene sheeting to protect the finish.
3. Cushion the instrument on all sides by tightly packing dunnage or urethane between the carton and the instrument. Allow three inches on all sides for cushioning.
4. Seal the carton with shipping tape or an industrial stapler.

Options

The A Options accommodate the various national electrical power connections. A number of other options are also available. Option 1 adds four more analog black outputs and option 2 adds two additional test signal outputs.

Power Cord Options

Any of the following power cord options can be ordered for the SPG 422. If no power cord option is ordered, instruments are shipped with a North American 125 V power cord.

Option A1. Universal Europe, 220V/16A Power Plug (power cord and one replacement fuse)

Option A2. United Kingdom, 240V/15A Power Plug (power cord and one replacement fuse)

Option A3. Australian, 240V/10A Power Plug (power cord and one replacement fuse)

Option A4 North American, 250V/10A Power Plug (power cord and one replacement fuse)

Unless otherwise specified, power cords for use in North America are UL listed and CSA certified. Cords for use in areas other than North America are approved by at least one test house acceptable in the country to which the product is shipped. Power cord part numbers are shown on the “Accessories” pull-out.

Option 1 — Additional Black Outputs

Option 1 adds four additional analog black outputs to the two outputs that are standard on the SPG 422. This is accomplished by adding a board to the SPG 422 and can be done at the factory or as a field upgrade. Any additional information required to operate the SPG 422 with option 1 installed is already incorporated into the documentation and is given wherever applicable throughout this manual.

Option 2 — Adding Serial Test Signals

Option 2 adds serial test signals and two additional outputs to the SPG 422. This allows the SPG 422 more flexibility to test a serial digital system and still act as a master sync generator. This option adds a board to the instrument. Any additional information required to operate the SPG 422 with the option 2 is included where applicable throughout this manual.

Ordering

Any of these options can be ordered with the SPG 422. In addition, these items are available from your nearest Tektronix field office or distributor. Be sure to include both the name and number of any Field Upgrades Kits ordered.

Replaceable Electrical Parts

This section contains a list of the electrical components for the SPG 422. Use this list to identify and order replacement parts.

Parts Ordering Information

Replacement parts are available through your local Tektronix field office or representative.

Changes to Tektronix products are sometimes made to accommodate improved components as they become available and to give you the benefit of the latest improvements. Therefore, when ordering parts, it is important to include the following information in your order:

- Part number
- Instrument type or model number
- Instrument serial number
- Instrument modification number, if applicable

If you order a part that has been replaced with a different or improved part, your local Tektronix field office or representative will contact you concerning any change in part number.

Change information, if any, is located at the rear of this manual.

Using the Replaceable Electrical Parts List

The tabular information in the Replaceable Electrical Parts List is arranged for quick retrieval. Understanding the structure and features of the list will help you find all of the information you need for ordering replacement parts. The following table describes each column of the electrical parts list.

Parts list column descriptions

Column	Column name	Description
1	Component number	The component number appears on diagrams and circuit board illustrations, located in the diagrams section. Assembly numbers are clearly marked on each diagram and circuit board illustration in the <i>Diagrams</i> section, and on the mechanical exploded views in the <i>Replaceable Mechanical Parts</i> list section. The component number is obtained by adding the assembly number prefix to the circuit number (see Component Number illustration following this table). The electrical parts list is arranged by assemblies in numerical sequence (A1, with its subassemblies and parts, precedes A2, with its subassemblies and parts). Chassis-mounted parts have no assembly number prefix, and they are located at the end of the electrical parts list.
2	Tektronix part number	Use this part number when ordering replacement parts from Tektronix.
3 and 4	Serial number	Column three indicates the serial number at which the part was first effective. Column four indicates the serial number at which the part was discontinued. No entry indicates the part is good for all serial numbers.
5	Name & description	An item name is separated from the description by a colon (:). Because of space limitations, an item name may sometimes appear as incomplete. Use the U.S. Federal Catalog handbook H6-1 for further item name identification.
6	Mfr. code	This indicates the code number of the actual manufacturer of the part.
7	Mfr. part number	This indicates the actual manufacturer's or vendor's part number.

Abbreviations

Abbreviations conform to American National Standard ANSI Y1.1–1972.

Component Number

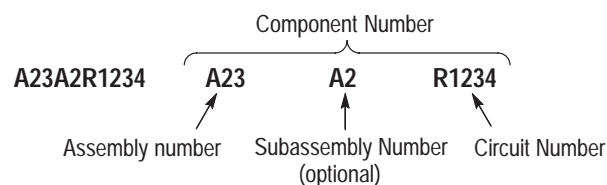

Read: Resistor 1234 (of Subassembly 2) of Assembly 23

List of Assemblies

A list of assemblies is located at the beginning of the electrical parts list. The assemblies are listed in numerical order. When a part's complete component number is known, this list will identify the assembly in which the part is located.

Chassis Parts

Chassis-mounted parts and cable assemblies are located at the end of the Replaceable Electrical Parts List.

Mfr. Code to Manufacturer Cross Index

The table titled Manufacturers Cross Index shows codes, names, and addresses of manufacturers or vendors of components listed in the parts list.

Manufacturers cross index

Mfr. code	Manufacturer	Address	City, state, zip code
D5243	ROEDERSTEIN ERNST GMBH	LUDMILLASTRASSE 23	8300 LANDSHUT GERMANY
TK0IU	OPTREX CORPORATION	3-14-9 YUSHIMA, BUNKYO-KU	TOKYO 113 JAPAN
TK0198	AVNET INC	AVNET ELECTRONICS MKTG, AMERICA 15580 SW JAY STREET	BEAVERTON, OR 97006
TK0435	LEWIS SCREW CO	4300 S RACINE AVE	CHICAGO IL 60609-3320
TK0515	EVOX-RIFA INC	100 TRI-STATE INTERNATIONAL, SUITE 290	LINCOLNSHIRE IL 60015
TK0891	MICONICS	1 FAIRCHILD AVE	PLAINVIEW NY 11803
TK1386	PYRAMID ELECTRONICS SUPPLY INC	9757 JUANITA DRIVE NE	KIRKLAND WA 98034
TK1442	TAIYO-YUDEN (USA) INC	ARLINGTON CENTER, 714 W ALGONQUIN RD	ARLINGTON HEIGHTS IL 60005
TK1547	MOORE ELECTRONICS INC (DIST)	19500 SW 90TH COURT PO BOX 1030	TUALATIN OR 97062
TK1727	PHILIPS NEDERLAND BV AFD ELONCO	POSTBUS 90050	5600 PB EINDHOVEN THE NETHERLANDS
TK1743	UNITRODE (UK) LTD	6 CRESSWELL PARK BLACKHEATH	LONDON SE 3 9RD ENGLAND
TK1857	HIROSE ELECTRIC USA INC	2688 WESTHILLS COURT	SIMI VALLEY, CA 93065-6235
TK1913	WIMATHE INTER-TECHNICAL GROUP IND	2269 SAW MILL RIVER ROAD, PO BOX 127	ELMSFORD NY 10523
TK2058	TDK CORPORATION OF AMERICA	1600 FEEHANVILLE DRIVE	MOUNT PROSPECT, IL 60056
TK2073	TOKYO AMERICA INC	565 W GULF ROAD	ARLINGTON HEIGHTS IL 60005
TK2319	COLLMER	14368 PROTON RD	DALLAS TX 75244
TK2469	UNITREK CORPORATION	3000 LEWIS & CLARK WAY, SUITE #2	VANCOUVER WA 98601
TK2519	ALLIANCE SEMICONDUCTOR	3099 N FIRST ST.	SAN JOSE, CA 95134-2006
TK2598	MAXIM - ASIC	14150 SW KARL BRAUN DRIVE	BEAVERTON, OR 97077
TK2635	DAITRON INC	27520A SW 95TH AVE, PO BOX 3500	WILSONVILLE, OR 97070
0B0A9	DALLAS SEMICONDUCTOR CORP	4350 BELTWOOD PKWY SOUTH	DALLAS TX 75244
0C8T6	CITEL AMERICA INC	1111 PARK CENTRE BLVD, SUITE 474	MIAMI, FL 33169
0GV52	SCHAFFNER EMC INC	9-B FADEM ROAD	SPRINGFIELD, NJ 07081
0H1N5	TOSHIBA MARCON ELECTRONICS AMERICA CORPORATION	998 FIRST EDGE DRIVE	VERNON HILLS IL 60061
0JR03	ZMAN MAGNETICS INC	7633 S 180th	KENT WA 98032
0JR04	TOSHIBA AMERICA INC ELECTRONICS COMPONENTS DIV	9775 TOLEDO WAY	IRVINE CA 92718
0J9R2	HARISON ELECTRIC CO LTD	ASAHIMACHI 5-CHOME IMABARI	EHIME JAPAN
0LUA3	PHILIPS COMPONENTS	100 PROVIDENCE PIKE	SLATERSVILLE, RI 02876
00779	AMP INC	2800 FULLING MILL PO BOX 3608	HARRISBURG PA 17105
01295	TEXAS INSTRUMENTS INC SEMICONDUCTOR GROUP	13500 N CENTRAL EXPY PO BOX 655303	DALLAS TX 75262-5303
01KV9	MERIX CORP	1521 POPLAR LANE PO BOX 3000	FOREST GROVE, OR 97116
02113	COILCRAFT INC	1102 SILVER LAKE RD	CARY IL 60013-1658

Manufacturers cross index (Cont.)

Mfr. code	Manufacturer	Address	City, state, zip code
04222	AVX/KYOCERA DIV OF AVX CORP	19TH AVE SOUTH P O BOX 867	MYRTLE BEACH SC 29577
04713	MOTOROLA INC SEMICONDUCTOR PRODUCTS SECTOR	5005 E MCDOWELL RD	PHOENIX AZ 85008-4229
05347	ULTRONIX INC	461 N 22ND, P O BOX 1090	GRAND JUNCTION, CO 81502
060D9	UNITREK CORPORATION	3000 COLUMBIA HOUSE BLVD, SUITE 120	VANCOUVER, WA 98661
07263	FAIRCHILD SEMICONDUCTOR CORPORATION	333 WESTERN AVE S.	SOUTH PORTLAND, ME 04106-1705
07933	RAYTHEON CO SEMICONDUCTOR DIV HQ	350 ELLIS ST	MOUNTAIN VIEW CA 94042
09969	DALE ELECTRONICS INC	EAST HIGHWAY 50, P O BOX 180	YANKTON SD 57078
1CH66	PHILIPS SEMICONDUCTORS	811 E ARQUES AVENUE, PO BOX 3409	SUNNYVALE CA 94088-3409
1ES66	MAXIM INTEGRATED PRODUCTS INC	120 SAN GABRIEL DRIVE	SUNNYVALE CA 94086
13103	THERMALLOY INC	2021 W. VALLEY VIEW LN, PO BOX 810839	DALLAS, TX 75381-5381
13919	BURR-BROWN RESEARCH CORP	6730 S TUCSON BLVD, P O BOX 11400	TUCSON AZ 85734
15454	KETEMA RODAN DIVISION	2900 BLUE STAR STREET	ANAHEIM CA 92806-2591
15542	MINI-CIRCUITS LABORATORY	2625 E 14TH ST	BROOKLYN NY 11235-3915
17856	SILICONIX INC	2201 LAURELWOOD RD	SANTA CLARA CA 95054-1516
19615	ALLEN AVIONICS INC	255 EAST 2ND ST P O BOX 350	MINEOLA NY 11501-3503
18565	CHOMERICS INC	77 DRAGON COURT	WOBURN, MA 01880
2W944	PAPST MECHATRONIC CORP	AQUIDNECK INDUSTRIAL PK	NEWPORT RI 02840
22526	BERG ELECTRONICS INC (DUPONT)	857 OLD TRAIL RD	ETTERS PA 17319
24165	SPRAGUE ELECTRIC CO	267 LOWELL ROAD	HUDSON, NH 03051
24355	ANALOG DEVICES INC	1 TECHNOLOGY DRIVE	NORWOOD MA 02062
24546	DALE ELECTRONICS INC	550 HIGH ST	BRADFORD, PA 16701
24931	SPECIALTY CONNECTOR CO INC	2100 EARLYWOOD DR, PO BOX 547	FRANKLIN IN 46131
26364	COMPONENTS CORP	6 KINSEY PLACE	DENVILLE NJ 07834-2611
27014	NATIONAL SEMICONDUCTOR CORP	2900 SEMICONDUCTOR DR	SANTA CLARA CA 95051-0606
31918	ITT SCHADOW INC	8081 WALLACE RD	EDEN PRAIRIE MN 55344-2224
33062	FERRONICS INC	45 O'CONNOR ROAD	FAIRPORT, NY 14450
33096	COLORADO CRYSTAL CORP	2303 W 8TH ST	LOVELAND CO 80537-5268
34335	ADVANCED MICRO DEVICES	901 THOMPSON PL, PO BOX 3453	SUNNYVALE CA 94086-3413
34371	HARRIS CORP HARRIS SEMICONDUCTOR PRODUCTS GROUP	200 PALM BAY BLVD PO BOX 883	MELBOURNE FL 32919
37964	GENNUM CORPORATION	970 FRASER DRIVE, PO BOX 489, STA A	BURLINGTON, ONTARIO, CANADA L7R 3Y3
4T165	NEC ELECTRONICS USA INC ELECTRON DIV	475 ELLIS ST PO BOX 7241	MOUNTAIN VIEW CA 94039
50139	ALLEN-BRADLEY CO ELECTRONIC COMPONENTS	1414 ALLEN BRADLEY DR	EL PASO TX 79936

Manufacturers cross index (Cont.)

Mfr. code	Manufacturer	Address	City, state, zip code
50434	HEWLETT-PACKARD CO OPTOELECTRONICS DIV	370 W TRIMBLE RD	SAN JOSE CA 95131-1008
53387	3M COMPANY ELECTRONIC PRODUCTS DIV	3M AUSTIN CENTER	AUSTIN TX 78769-2963
55322	SAMTEC INC	810 PROGRESS BLVD, PO BOX 1147	NEW ALBANY IN 47150-2257
55680	NICHICON /AMERICA/ CORP	927 E STATE PKY	SCHAUMBURG IL 60195-4526
56845	DALE ELECTRONICS INC	2300 RIVERSIDE BLVD, PO BOX 74	NORFOLK NE 68701-2242
57668	ROHM CORPORATION	15375 BARRANCA PARKWAY, SUITE B207	IRVINE CA 92718
59124	KOA SPEER ELECTRONICS INC	BOLIVAR DRIVE, PO BOX 547	BRADFORD PA 16701
61058	MATSUSHITA ELECTRIC CORP OF AMERICA	PANASONIC INDUSTRIAL CO DIV TWO PANASONIC WAY	SECAUCUS, NJ 07094
61271	FUJITSU MICROELECTRONICS INC ELECTRONICS COMPONENTS DIVISION	3545 NORTH FIRST	SAN JOSE, CA 95134-1804
61429	FOX ELECTRONICS DIV OF FOX ELECTRONICS INC	5842 CORPORATION CIRCLE	FOR MEYERS FL 33905
61529	AROMAT CORP	629 CENTRAL AVE	NEW PROVIDENCE NJ 07974
61772	INTEGRATED DEVICE TECHNOLOGY	3236 SCOTT BLVD	SANTA CLARA CA 95051
61935	SCHURTER INC	1016 CLEGG COURT	PETALUMA CA 94952-1152
62104	CALIFORNIA EASTERN LABORATORIES INC	4590 PATRICK HENRY DR	SANTA CLARA CA 95054-3309
62643	UNITED CHEMICON INC	9801 W HIGGINS ST, SUITE 430	ROSEMONT, IL 60018-4771
65786	CYPRESS SEMICONDUCTOR CORP	3901 N FIRST ST	SAN JOSE, CA 95134-1506
66958	SGS THOMSON MICROELECTRONICS	1000 E BELL RD	PHOENIX AZ 85022-2649
67183	ALTERA CORP	3525 MONROE ST	SANTA CLARA CA 95051
68994	XILINX INC	2100 LOGIC DRIVE	SAN JOSE CA 95124
71400	BUSSMANN DIV OF COOPER INDUSTRIES INC	114 OLD STATE RD PO BOX 14460	ST LOUIS MO 63178
75042	IRC ELECTRONIC COMPONENTS PHILADELPHIA DIV TRW FIXED RESISTORS	401 N BROAD ST	PHILADELPHIA PA 19108-1001
75498	MULTICOMP INC	3005 SW 154TH TERRACE #3	BEAVERTON OR 97006
80009	TEKTRONIX INC	14150 SW KARL BRAUN DR, PO BOX 500	BEAVERTON OR 97077-0001
81073	GRAYHILL INC	561 HILLGROVE AVE, PO BOX 10373	LA GRANGE IL 60525-5914
82389	SWITCHCRAFT INC SUB OF RAYTHEON CO	5555 N ELSTRON AVE	CHICAGO IL 60630-1314
90484	SURPRENANT WIRE AND CABLE DIV OF FL INDUSTRIES INC	172 STERLING ST	CLINTON MA 01510
91293	JOHANSON MFG CO	400 ROCKWAY VALLEY RD	BOONTON NJ 07005
91637	DALE ELECTRONICS INC	2064 12TH AVE, PO BOX 609	COLUMBUS NE 68601-3632
93907	CAMCAR DIV OF TEXTRON INC	ATTN: ALICIA SANFORD, 516 18TH AVE	ROCKFORD, IL 611045181

Replaceable Electrical Parts

Replaceable electrical parts list

Component number	Tektronix part number	Serial no. effective	Serial no. discontin'd	Name & description	Mfr. code	Mfr. part number
A1	671-3127-00	B010100	B021448	CKT BD ASSY:FRONT PANEL BOARD	80009	671312700
A1	671-3127-01	B021449		CKT BD ASSY:FRONT PANEL BOARD	80009	671312701
A2	671-3124-02	B020000	B020423	CKT BD ASSY:DIGITAL BOARD	80009	671312402
A2	671-3124-03	B020424	B020533	CKT BD ASSY:DIGITAL BOARD	80009	671312403
A2	671-3124-04	B020534	B021113	CKT BD ASSY:DIGITAL BOARD	80009	671312404
A2	671-3124-05	B021114	B021339	CKT BD ASSY:DIGITAL BOARD	80009	671312405
A2	671-3124-06	B021340	B022224	CKT BD ASSY:DIGITAL BOARD	80009	671312406
A2	671-3124-08	B022225	B033999	CKT BD ASSY:DIGITAL BOARD	80009	671312407
A2A1	119-4699-00			OVEN ASSEMBLY:TG2000	80009	119469900
A3	671-3123-01		B020517	CKT BD ASSY:OUTPUT BOARD	80009	671312301
A3	671-3123-02	B020518		CKT BD ASSY:OUTPUT BOARD	80009	671312302
A4	671-3242-00		B020515	CKT BD ASSY:POWER SUPPLY BOARD	80009	671324200
A4	671-3242-01	B020516	B020829	CKT BD ASSY:POWER SUPPLY BOARD	80009	671324201
A4	671-3242-03	B020830	B021139	CKT BD ASSY:POWER SUPPLY BOARD	80009	671324203
A4	671-3242-04	B021140	B021954	CKT BD ASSY:POWER SUPPLY BOARD	80009	671324204
A4	671-3242-05	B021955		CKT BD ASSY:POWER SUPPLY BOARD	80009	671324204
A5	671-3125-00			CKT BD ASSY:BLACK GENERATOR (OPTION 01 ONLY)	80009	671312500
A6	671-3126-01		B020533	CKT BD ASSY:TEST SIGNALBOARD (OPTION 02 ONLY)	80009	671312601
A6	671-3126-02	B020534	B021339	CKT BD ASSY:TEST SIGNALBOARD (OPTION 02 ONLY)	80009	671312602
A6	671-3126-03	B021340		CKT BD ASSY:TEST SIGNALBOARD (OPTION 02 ONLY)	80009	671312602
A7	671-2059-00			CIRCUIT BD ASSY:SERIAL FILTER	80009	671205900
A8	119-4809-00			DISPLAY MOD:LCD:320 X 240,DOT MATRIX NTNG AREA	TK0IU	DMC20261ANY-LY-
A1	671-3127-00		B021448	CKT BD ASSY:FRONT PANEL BOARD	80009	671312700
A1	671-3127-01	B021449		CKT BD ASSY:FRONT PANEL BOARD	80009	671312701
A1DS1	150-1223-00			DIODE,OPTO:LED;GRN,565NM,1.6MCD AT 10MA	50434	HLMP-3502
A1DS2	150-1223-00			DIODE,OPTO:LED;GRN,565NM,1.6MCD AT 10MA	50434	HLMP-3502
A1J1	174-2744-00			CA ASSY,SP,ELEC:34,28 AWG, 3.25 L,RIBBON	53387	174-2744-00
A1S1	260-2442-00		671-3127-00	SWITCH,PUSH:SPST;MOM,NO,100 GRM FRC,COND RUBBER CONTACTS,GRN LED,W/KEYCAP	TK1857	HL20-LSG

Replaceable electrical parts list (Cont.)

Component number	Tektronix part number	Serial no. effective	Serial no. discont'd	Name & description	Mfr. code	Mfr. part number
A1S1	260-2671-00	671-3127-01		SWITCH,PUSH:SPST;MOM,NO,100 GRM FRC,COND RUBBER CONTACTS,GRN LED,W/KEYCAP	TK2635	SKECFL
				ATTACHED PARTS		
	366-0671-00		671-3127-00	PUSH BUTTON:W/LENS,HL20-1101	TK1857	HL20-1101
	366-0779-00	671-3127-01		PUSH BUTTON:PUSH BUTTON,KEYTOP W/LENS,VM700A	TK2635	SCGRY1
				END ATTACHED PARTS		
A1S2	260-2442-00		671-3127-00	SWITCH,PUSH:SPST;MOM,NO,100 GRM FRC,COND RUBBER CONTACTS,GRN LED,W/KEYCAP	TK1857	HL20-LSG
A1S2	260-2671-00	671-3127-01		SWITCH,PUSH:SPST;MOM,NO,100 GRM FRC,COND RUBBER CONTACTS,GRN LED,W/KEYCAP	TK2635	SKECFL
				ATTACHED PARTS		
	366-0671-00		671-3127-00	PUSH BUTTON:W/LENS,HL20-1101	TK1857	HL20-1101
	366-0779-00	671-3127-01		PUSH BUTTON:PUSH BUTTON,KEYTOP W/LENS,VM700A	TK2635	SCGRY1
				END ATTACHED PARTS		
A1S3	260-2442-00		671-3127-00	SWITCH,PUSH:SPST;MOM,NO,100 GRM FRC,COND RUBBER CONTACTS,GRN LED,W/KEYCAP	TK1857	HL20-LSG
A1S3	260-2671-00	671-3127-01		SWITCH,PUSH:SPST;MOM,NO,100 GRM FRC,COND RUBBER CONTACTS,GRN LED,W/KEYCAP	TK2635	SKECFL
				ATTACHED PARTS		
	366-0671-00		671-3127-00	PUSH BUTTON:W/LENS,HL20-1101	TK1857	HL20-1101
	366-0779-00	671-3127-01		PUSH BUTTON:PUSH BUTTON,KEYTOP W/LENS,VM700A	TK2635	SCGRY1
				END ATTACHED PARTS		
A1S4	260-2442-00		671-3127-00	SWITCH,PUSH:SPST;MOM,NO,100 GRM FRC,COND RUBBER CONTACTS,GRN LED,W/KEYCAP	TK1857	HL20-LSG
A1S4	260-2671-00	671-3127-01		SWITCH,PUSH:SPST;MOM,NO,100 GRM FRC,COND RUBBER CONTACTS,GRN LED,W/KEYCAP	TK2635	SKECFL
				ATTACHED PARTS		
	366-0671-00		671-3127-00	PUSH BUTTON:W/LENS,HL20-1101	TK1857	HL20-1101
	366-0779-00	671-3127-01		PUSH BUTTON:PUSH BUTTON,KEYTOP W/LENS,VM700A	TK2635	SCGRY1
				END ATTACHED PARTS		
A1S5	260-2442-00		671-3127-00	SWITCH,PUSH:SPST;MOM,NO,100 GRM FRC,COND RUBBER CONTACTS,GRN LED,W/KEYCAP	TK1857	HL20-LSG
A1S5	260-2671-00	671-3127-01		SWITCH,PUSH:SPST;MOM,NO,100 GRM FRC,COND RUBBER CONTACTS,GRN LED,W/KEYCAP	TK2635	SKECFL
				ATTACHED PARTS		
	366-0671-00		671-3127-00	PUSH BUTTON:W/LENS,HL20-1101	TK1857	HL20-1101
	366-0779-00	671-3127-01		PUSH BUTTON:PUSH BUTTON,KEYTOP W/LENS,VM700A	TK2635	SCGRY1
				END ATTACHED PARTS		
A1S6	260-2442-00		671-3127-00	SWITCH,PUSH:SPST;MOM,NO,100 GRM FRC,COND RUBBER CONTACTS,GRN LED,W/KEYCAP	TK1857	HL20-LSG
A1S6	260-2671-00	671-3127-01		SWITCH,PUSH:SPST;MOM,NO,100 GRM FRC,COND RUBBER CONTACTS,GRN LED,W/KEYCAP	TK2635	SKECFL

Replaceable Electrical Parts

Replaceable electrical parts list (Cont.)

Component number	Tektronix part number	Serial no. effective	Serial no. discontin'd	Name & description	Mfr. code	Mfr. part number
				ATTACHED PARTS		
	366-0671-00		671-3127-00	PUSH BUTTON:W/LENS,HL20-1101	TK1857	HL20-1101
	366-0779-00	671-3127-01		PUSH BUTTON:PUSH BUTTON,KEYTOP W/LENS,VM700A	TK2635	SCGRY1
				END ATTACHED PARTS		
A1S7	260-2442-00		671-3127-00	SWITCH,PUSH:SPST;MOM,NO,100 GRM FRC,COND RUBBER CONTACTS,GRN LED,W/KEYCAP	TK1857	HL20-LSG
A1S7	260-2671-00	671-3127-01		SWITCH,PUSH:SPST;MOM,NO,100 GRM FRC,COND RUBBER CONTACTS,GRN LED,W/KEYCAP	TK2635	SKECFL
				ATTACHED PARTS		
	366-0671-00		671-3127-00	PUSH BUTTON:W/LENS,HL20-1101	TK1857	HL20-1101
	366-0779-00	671-3127-01		PUSH BUTTON:PUSH BUTTON,KEYTOP W/LENS,VM700A	TK2635	SCGRY1
				END ATTACHED PARTS		
A1S8	260-2442-00		671-3127-00	SWITCH,PUSH:SPST;MOM,NO,100 GRM FRC,COND RUBBER CONTACTS,GRN LED,W/KEYCAP	TK1857	HL20-LSG
A1S8	260-2671-00	671-3127-01		SWITCH,PUSH:SPST;MOM,NO,100 GRM FRC,COND RUBBER CONTACTS,GRN LED,W/KEYCAP	TK2635	SKECFL
				ATTACHED PARTS		
	366-0671-00		671-3127-00	PUSH BUTTON:W/LENS,HL20-1101	TK1857	HL20-1101
	366-0779-00	671-3127-01		PUSH BUTTON:PUSH BUTTON,KEYTOP W/LENS,VM700A	TK2635	SCGRY1
				END ATTACHED PARTS		
A1S9	260-2442-00		671-3127-00	SWITCH,PUSH:SPST;MOM,NO,100 GRM FRC,COND RUBBER CONTACTS,GRN LED,W/KEYCAP	TK1857	HL20-LSG
A1S9	260-2671-00	671-3127-01		SWITCH,PUSH:SPST;MOM,NO,100 GRM FRC,COND RUBBER CONTACTS,GRN LED,W/KEYCAP	TK2635	SKECFL
				ATTACHED PARTS		
	366-0671-00		671-3127-00	PUSH BUTTON:W/LENS,HL20-1101	TK1857	HL20-1101
	366-0779-00	671-3127-01		PUSH BUTTON:PUSH BUTTON,KEYTOP W/LENS,VM700A	TK2635	SCGRY1
				END ATTACHED PARTS		
A1S10	260-2442-00		671-3127-00	SWITCH,PUSH:SPST;MOM,NO,100 GRM FRC,COND RUBBER CONTACTS,GRN LED,W/KEYCAP	TK1857	HL20-LSG
A1S10	260-2671-00	671-3127-01		SWITCH,PUSH:SPST;MOM,NO,100 GRM FRC,COND RUBBER CONTACTS,GRN LED,W/KEYCAP	TK2635	SKECFL
				ATTACHED PARTS		
	366-0671-00		671-3127-00	PUSH BUTTON:W/LENS,HL20-1101	TK1857	HL20-1101
	366-0779-00	671-3127-01		PUSH BUTTON:PUSH BUTTON,KEYTOP W/LENS,VM700A	TK2635	SCGRY1
				END ATTACHED PARTS		
A1S11	260-2442-00		671-3127-00	SWITCH,PUSH:SPST;MOM,NO,100 GRM FRC,COND RUBBER CONTACTS,GRN LED,W/KEYCAP	TK1857	HL20-LSG
A1S11	260-2671-00	671-3127-01		SWITCH,PUSH:SPST;MOM,NO,100 GRM FRC,COND RUBBER CONTACTS,GRN LED,W/KEYCAP	TK2635	SKECFL
				ATTACHED PARTS		
	366-0671-00		671-3127-00	PUSH BUTTON:W/LENS,HL20-1101	TK1857	HL20-1101

Replaceable electrical parts list (Cont.)

Component number	Tektronix part number	Serial no. effective	Serial no. discount'd	Name & description	Mfr. code	Mfr. part number
	366-0779-00	671-3127-01		PUSH BUTTON:PUSH BUTTON,KEYTOP W/LENS,VM700A	TK2635	SCGRY1
				END ATTACHED PARTS		
A1S12	260-2442-00		671-3127-00	SWITCH,PUSH:SPST;MOM,NO,100 GRM FRC,COND RUBBER CONTACTS,GRN LED,W/KEYCAP	TK1857	HL20-LSG
A1S12	260-2671-00	671-3127-01		SWITCH,PUSH:SPST;MOM,NO,100 GRM FRC,COND RUBBER CONTACTS,GRN LED,W/KEYCAP	TK2635	SKECFL
	366-0671-00		671-3127-00	PUSH BUTTON:W/LENS,HL20-1101	TK1857	HL20-1101
	366-0779-00	671-3127-01		PUSH BUTTON:PUSH BUTTON,KEYTOP W/LENS,VM700A	TK2635	SCGRY1
A1S14	260-2442-00		671-3127-00	SWITCH,PUSH:SPST;MOM,NO,100 GRM FRC,COND RUBBER CONTACTS,GRN LED,W/KEYCAP	TK1857	HL20-LSG
A1S14	260-2671-00	671-3127-01		SWITCH,PUSH:SPST;MOM,NO,100 GRM FRC,COND RUBBER CONTACTS,GRN LED,W/KEYCAP	TK2635	SKECFL
	366-0671-00		671-3127-00	PUSH BUTTON:W/LENS,HL20-1101	TK1857	HL20-1101
	366-0779-00	671-3127-01		PUSH BUTTON:PUSH BUTTON,KEYTOP W/LENS,VM700A	TK2635	SCGRY1
A1S15	260-2442-00		671-3127-00	SWITCH,PUSH:SPST;MOM,NO,100 GRM FRC,COND RUBBER CONTACTS,GRN LED,W/KEYCAP	TK1857	HL20-LSG
A1S15	260-2671-00	671-3127-01		SWITCH,PUSH:SPST;MOM,NO,100 GRM FRC,COND RUBBER CONTACTS,GRN LED,W/KEYCAP	TK2635	SKECFL
	366-0671-00		671-3127-00	PUSH BUTTON:W/LENS,HL20-1101	TK1857	HL20-1101
	366-0779-00	671-3127-01		PUSH BUTTON:PUSH BUTTON,KEYTOP W/LENS,VM700A	TK2635	SCGRY1
A1S16	260-2442-00		671-3127-00	SWITCH,PUSH:SPST;MOM,NO,100 GRM FRC,COND RUBBER CONTACTS,GRN LED,W/KEYCAP	TK1857	HL20-LSG
A1S16	260-2671-00	671-3127-01		SWITCH,PUSH:SPST;MOM,NO,100 GRM FRC,COND RUBBER CONTACTS,GRN LED,W/KEYCAP	TK2635	SKECFL
	366-0671-00		671-3127-00	PUSH BUTTON:W/LENS,HL20-1101	TK1857	HL20-1101
	366-0779-00	671-3127-01		PUSH BUTTON:PUSH BUTTON,KEYTOP W/LENS,VM700A	TK2635	SCGRY1
A1S17	260-2442-00		671-3127-00	SWITCH,PUSH:SPST;MOM,NO,100 GRM FRC,COND RUBBER CONTACTS,GRN LED,W/KEYCAP	TK1857	HL20-LSG
A1S17	260-2671-00	671-3127-01		SWITCH,PUSH:SPST;MOM,NO,100 GRM FRC,COND RUBBER CONTACTS,GRN LED,W/KEYCAP	TK2635	SKECFL
				ATTACHED PARTS		
	366-0779-00	671-3127-01		PUSH BUTTON:PUSH BUTTON,KEYTOP W/LENS,VM700A	TK2635	SCGRY1
A1S18	260-2442-00		671-3127-00	SWITCH,PUSH:SPST;MOM,NO,100 GRM FRC,COND RUBBER CONTACTS,GRN LED,W/KEYCAP	TK1857	HL20-LSG
A1S18	260-2671-00	671-3127-01		SWITCH,PUSH:SPST;MOM,NO,100 GRM FRC,COND RUBBER CONTACTS,GRN LED,W/KEYCAP	TK2635	SKECFL
	366-0671-00		671-3127-00	PUSH BUTTON:W/LENS,HL20-1101	TK1857	HL20-1101
	366-0779-00	671-3127-01		PUSH BUTTON:PUSH BUTTON,KEYTOP W/LENS,VM700A	TK2635	SCGRY1

Replaceable electrical parts list

Component number	Tektronix part number	Serial no. effective	Serial no. discont'd	Name & description	Mfr. code	Mfr. part number
A2	671-3124-02		B020423	CKT BD ASSY:DIGITAL BOARD	80009	671312402
A2	671-3124-03	B020424	B020533	CKT BD ASSY:DIGITAL BOARD	80009	671312403
A2	671-3124-04	B020534	B021113	CKT BD ASSY:DIGITAL BOARD	80009	671312404
A2	671-3124-05	B021114	B021330	CKT BD ASSY:DIGITAL BOARD	80009	671312405
A2	671-3124-06	B021340	B022224	CKT BD ASSY:DIGITAL BOARD	80009	671312406
A2	671-3124-08	B022225	B033999	CKT BD ASSY:DIGITAL BOARD	80009	671312407
A2A1	119-4699-00			OVEN ASSEMBLY:TG2000	80009	119469900
A2C1	283-5098-00			CAP,FXD,CER:MLC;0.1UF,+80%-20%,50V,Z5U,1206	04222	12065E104ZAT3A
A2C2	290-0963-00			CAP,FXD,ALUM:220UF,+50-20%,25WVDC,10 X12MM	55680	UVX1V221MPA
A2C4	283-5098-00			CAP,FXD,CER:MLC;0.1UF,+80%-20%,50V,Z5U,1206	04222	12065E104ZAT3A
A2C5	283-5098-00			CAP,FXD,CER:MLC;0.1UF,+80%-20%,50V,Z5U,1206	04222	12065E104ZAT3A
A2C6	283-5098-00			CAP,FXD,CER:MLC;0.1UF,+80%-20%,50V,Z5U,1206	04222	12065E104ZAT3A
A2C7	283-5098-00			CAP,FXD,CER:MLC;0.1UF,+80%-20%,50V,Z5U,1206	04222	12065E104ZAT3A
A2C8	283-5098-00			CAP,FXD,CER:MLC;0.1UF,+80%-20%,50V,Z5U,1206	04222	12065E104ZAT3A
A2C9	283-5098-00			CAP,FXD,CER:MLC;0.1UF,+80%-20%,50V,Z5U,1206	04222	12065E104ZAT3A
A2C10	283-5098-00			CAP,FXD,CER:MLC;0.1UF,+80%-20%,50V,Z5U,1206	04222	12065E104ZAT3A
A2C11	290-0963-00			CAP,FXD,ALUM:220UF,+50-20%,25WVDC,10 X12MM	55680	UVX1V221MPA
A2C12	290-0963-00			CAP,FXD,ALUM:220UF,+50-20%,25WVDC,10 X12MM	55680	UVX1V221MPA
A2C13	290-0963-00			CAP,FXD,ALUM:220UF,+50-20%,25WVDC,10 X12MM	55680	UVX1V221MPA
A2C15	283-5098-00			CAP,FXD,CER:MLC;0.1UF,+80%-20%,50V,Z5U,1206	04222	12065E104ZAT3A
A2C16	283-5098-00			CAP,FXD,CER:MLC;0.1UF,+80%-20%,50V,Z5U,1206	04222	12065E104ZAT3A
A2C17	283-5098-00			CAP,FXD,CER:MLC;0.1UF,+80%-20%,50V,Z5U,1206	04222	12065E104ZAT3A
A2C19	283-5098-00			CAP,FXD,CER:MLC;0.1UF,+80%-20%,50V,Z5U,1206	04222	12065E104ZAT3A
A2C20	283-5098-00			CAP,FXD,CER:MLC;0.1UF,+80%-20%,50V,Z5U,1206	04222	12065E104ZAT3A
A2C21	283-5098-00			CAP,FXD,CER:MLC;0.1UF,+80%-20%,50V,Z5U,1206	04222	12065E104ZAT3A
A2C22	283-5098-00			CAP,FXD,CER:MLC;0.1UF,+80%-20%,50V,Z5U,1206	04222	12065E104ZAT3A
A2C24	290-0963-00			CAP,FXD,ALUM:220UF,+50-20%,25WVDC,10 X12MM	55680	UVX1V221MPA
A2C27	283-5098-00			CAP,FXD,CER:MLC;0.1UF,+80%-20%,50V,Z5U,1206	04222	12065E104ZAT3A
A2C28	283-5098-00			CAP,FXD,CER:MLC;0.1UF,+80%-20%,50V,Z5U,1206	04222	12065E104ZAT3A
A2C29	283-5098-00			CAP,FXD,CER:MLC;0.1UF,+80%-20%,50V,Z5U,1206	04222	12065E104ZAT3A
A2C30	283-5098-00			CAP,FXD,CER:MLC;0.1UF,+80%-20%,50V,Z5U,1206	04222	12065E104ZAT3A
A2C39	283-5098-00			CAP,FXD,CER:MLC;0.1UF,+80%-20%,50V,Z5U,1206	04222	12065E104ZAT3A
A2C40	283-5098-00			CAP,FXD,CER:MLC;0.1UF,+80%-20%,50V,Z5U,1206	04222	12065E104ZAT3A
A2C41	283-5098-00			CAP,FXD,CER:MLC;0.1UF,+80%-20%,50V,Z5U,1206	04222	12065E104ZAT3A
A2C42	283-5098-00			CAP,FXD,CER:MLC;0.1UF,+80%-20%,50V,Z5U,1206	04222	12065E104ZAT3A
A2C45	283-5098-00			CAP,FXD,CER:MLC;0.1UF,+80%-20%,50V,Z5U,1206	04222	12065E104ZAT3A
A2C46	283-5098-00			CAP,FXD,CER:MLC;0.1UF,+80%-20%,50V,Z5U,1206	04222	12065E104ZAT3A
A2C47	283-5098-00			CAP,FXD,CER:MLC;0.1UF,+80%-20%,50V,Z5U,1206	04222	12065E104ZAT3A

Replaceable electrical parts list (Cont.)

Component number	Tektronix part number	Serial no. effective	Serial no. discont'd	Name & description	Mfr. code	Mfr. part number
A2C48	283-5098-00			CAP,FXD,CER:MLC;0.1UF,+80%-20%,50V,Z5U,1206	04222	12065E104ZAT3A
A2C49	283-5098-00			CAP,FXD,CER:MLC;0.1UF,+80%-20%,50V,Z5U,1206	04222	12065E104ZAT3A
A2C50	283-5098-00			CAP,FXD,CER:MLC;0.1UF,+80%-20%,50V,Z5U,1206	04222	12065E104ZAT3A
A2C51	283-5098-00			CAP,FXD,CER:MLC;0.1UF,+80%-20%,50V,Z5U,1206	04222	12065E104ZAT3A
A2C52	283-5098-00			CAP,FXD,CER:MLC;0.1UF,+80%-20%,50V,Z5U,1206	04222	12065E104ZAT3A
A2C53	283-5098-00			CAP,FXD,CER:MLC;0.1UF,+80%-20%,50V,Z5U,1206	04222	12065E104ZAT3A
A2C54	283-5098-00			CAP,FXD,CER:MLC;0.1UF,+80%-20%,50V,Z5U,1206	04222	12065E104ZAT3A
A2C55	283-5098-00			CAP,FXD,CER:MLC;0.1UF,+80%-20%,50V,Z5U,1206	04222	12065E104ZAT3A
A2C56	283-5098-00			CAP,FXD,CER:MLC;0.1UF,+80%-20%,50V,Z5U,1206	04222	12065E104ZAT3A
A2C57	283-5098-00			CAP,FXD,CER:MLC;0.1UF,+80%-20%,50V,Z5U,1206	04222	12065E104ZAT3A
A2C58	283-5098-00			CAP,FXD,CER:MLC;0.1UF,+80%-20%,50V,Z5U,1206	04222	12065E104ZAT3A
A2C59	283-5098-00			CAP,FXD,CER:MLC;0.1UF,+80%-20%,50V,Z5U,1206	04222	12065E104ZAT3A
A2C60	283-5098-00			CAP,FXD,CER:MLC;0.1UF,+80%-20%,50V,Z5U,1206	04222	12065E104ZAT3A
A2C61	290-5037-01			CAP,FXD,ALUM:10UF,20%,35V,5.7 H X 5 DIA MM	62643	MVK35VC10RME60T
A2C62	283-5098-00			CAP,FXD,CER:MLC;0.1UF,+80%-20%,50V,Z5U,1206	04222	12065E104ZAT3A
A2C63	283-5098-00			CAP,FXD,CER:MLC;0.1UF,+80%-20%,50V,Z5U,1206	04222	12065E104ZAT3A
A2C64	283-5098-00			CAP,FXD,CER:MLC;0.1UF,+80%-20%,50V,Z5U,1206	04222	12065E104ZAT3A
A2C65	283-5098-00			CAP,FXD,CER:MLC;0.1UF,+80%-20%,50V,Z5U,1206	04222	12065E104ZAT3A
A2C66	283-5098-00			CAP,FXD,CER:MLC;0.1UF,+80%-20%,50V,Z5U,1206	04222	12065E104ZAT3A
A2C67	283-5098-00			CAP,FXD,CER:MLC;0.1UF,+80%-20%,50V,Z5U,1206	04222	12065E104ZAT3A
A2C68	283-5098-00			CAP,FXD,CER:MLC;0.1UF,+80%-20%,50V,Z5U,1206	04222	12065E104ZAT3A
A2C69	283-5098-00			CAP,FXD,CER:MLC;0.1UF,+80%-20%,50V,Z5U,1206	04222	12065E104ZAT3A
A2C70	283-5098-00			CAP,FXD,CER:MLC;0.1UF,+80%-20%,50V,Z5U,1206	04222	12065E104ZAT3A
A2C71	283-5098-00			CAP,FXD,CER:MLC;0.1UF,+80%-20%,50V,Z5U,1206	04222	12065E104ZAT3A
A2C72	283-5098-00			CAP,FXD,CER:MLC;0.1UF,+80%-20%,50V,Z5U,1206	04222	12065E104ZAT3A
A2C73	283-5098-00			CAP,FXD,CER:MLC;0.1UF,+80%-20%,50V,Z5U,1206	04222	12065E104ZAT3A
A2C74	283-5098-00			CAP,FXD,CER:MLC;0.1UF,+80%-20%,50V,Z5U,1206	04222	12065E104ZAT3A
A2C75	283-5098-00			CAP,FXD,CER:MLC;0.1UF,+80%-20%,50V,Z5U,1206	04222	12065E104ZAT3A
A2C76	283-5098-00			CAP,FXD,CER:MLC;0.1UF,+80%-20%,50V,Z5U,1206	04222	12065E104ZAT3A
A2C77	283-5098-00			CAP,FXD,CER:MLC;0.1UF,+80%-20%,50V,Z5U,1206	04222	12065E104ZAT3A
A2C78	283-5098-00			CAP,FXD,CER:MLC;0.1UF,+80%-20%,50V,Z5U,1206	04222	12065E104ZAT3A
A2C79	283-5098-00			CAP,FXD,CER:MLC;0.1UF,+80%-20%,50V,Z5U,1206	04222	12065E104ZAT3A
A2C80	283-5098-00			CAP,FXD,CER:MLC;0.1UF,+80%-20%,50V,Z5U,1206	04222	12065E104ZAT3A
A2C81	283-5098-00			CAP,FXD,CER:MLC;0.1UF,+80%-20%,50V,Z5U,1206	04222	12065E104ZAT3A
A2C82	283-5203-00			CAP,FXD,CER:MLC;1000PF,10%,100V,X7R,1206	04222	12061C102KAT1A
A2C83	283-5267-00			CAP,FXD,CER:MLC;1UF,+80%-20%,25V,Y5V,1206	04222	12063G105ZAT1A
A2C84	283-5203-00			CAP,FXD,CER:MLC;1000PF,10%,100V,X7R,1206	04222	12061C102KAT1A
A2C85	283-5203-00			CAP,FXD,CER:MLC;1000PF,10%,100V,X7R,1206	04222	12061C102KAT1A

Replaceable electrical parts list (Cont.)

Component number	Tektronix part number	Serial no. effective	Serial no. discont'd	Name & description	Mfr. code	Mfr. part number
A2C86	283-5003-00			CAP,FXD,CER:MLC;0.01UF,10%,50V,X7R,1206	TK2058	C3216X7R1H103K-
A2C87	283-5003-00			CAP,FXD,CER:MLC;0.01UF,10%,50V,X7R,1206	TK2058	C3216X7R1H103K-
A2C88	283-5202-00			CAP,FXD,CER:MLC;0.022UF,10%,50V,X7R,1206,SMD,8MM	04222	12065C223KAT1A
A2C89	283-5203-00			CAP,FXD,CER:MLC;1000PF,10%,100V,X7R,1206	04222	12061C102KAT1A
A2C91	283-5003-00			CAP,FXD,CER:MLC;0.01UF,10%,50V,X7R,1206	TK2058	C3216X7R1H103K-
A2C92	283-5003-00			CAP,FXD,CER:MLC;0.01UF,10%,50V,X7R,1206	TK2058	C3216X7R1H103K-
A2C93	283-5202-00			CAP,FXD,CER:MLC;0.022UF,10%,50V,X7R,1206,SMD,8MM	04222	12065C223KAT1A
A2C94	283-5203-00			CAP,FXD,CER:MLC;1000PF,10%,100V,X7R,1206	04222	12061C102KAT1A
A2C95	283-5203-00			CAP,FXD,CER:MLC;1000PF,10%,100V,X7R,1206	04222	12061C102KAT1A
A2C97	283-5098-00			CAP,FXD,CER:MLC;0.1UF,+80%-20%,50V,Z5U,1206	04222	12065E104ZAT3A
A2C98	283-5267-00			CAP,FXD,CER:MLC;1UF,+80%-20%,25V,Y5V,1206	04222	12063G105ZAT1A
A2C99	283-5044-00			CAP,FXD,CER:MLC;1.5PF,+/-0.25PF,50V,NPO,1206	TK2058	C3216C0G1H1R5C-
A2C100	283-5044-00			CAP,FXD,CER:MLC;1.5PF,+/-0.25PF,50V,NPO,1206	TK2058	C3216C0G1H1R5C-
A2C101	283-5267-00			CAP,FXD,CER:MLC;1UF,+80%-20%,25V,Y5V,1206	04222	12063G105ZAT1A
A2C102	283-5098-00			CAP,FXD,CER:MLC;0.1UF,+80%-20%,50V,Z5U,1206	04222	12065E104ZAT3A
A2C103	283-5203-00			CAP,FXD,CER:MLC;1000PF,10%,100V,X7R,1206	04222	12061C102KAT1A
A2C104	283-5203-00			CAP,FXD,CER:MLC;1000PF,10%,100V,X7R,1206	04222	12061C102KAT1A
A2C105	283-5203-00			CAP,FXD,CER:MLC;1000PF,10%,100V,X7R,1206	04222	12061C102KAT1A
A2C106	283-5203-00			CAP,FXD,CER:MLC;1000PF,10%,100V,X7R,1206	04222	12061C102KAT1A
A2C107	290-0963-00			CAP,FXD,ALUM;220UF,+50-20%,25WVDC,10 X12MM	55680	UVX1V221MPA
A2C108	283-5098-00			CAP,FXD,CER:MLC;0.1UF,+80%-20%,50V,Z5U,1206	04222	12065E104ZAT3A
A2C109	283-5098-00			CAP,FXD,CER:MLC;0.1UF,+80%-20%,50V,Z5U,1206	04222	12065E104ZAT3A
A2C110	283-5003-00			CAP,FXD,CER:MLC;0.01UF,10%,50V,X7R,1206	TK2058	C3216X7R1H103K-
A2C111	283-5098-00			CAP,FXD,CER:MLC;0.1UF,+80%-20%,50V,Z5U,1206	04222	12065E104ZAT3A
A2C112	290-5037-01			CAP,FXD,ALUM;10UF,20%,35V,5.7 H X 5 DIA MM	62643	MVK35VC10RME60T
A2C113	283-5098-00			CAP,FXD,CER:MLC;0.1UF,+80%-20%,50V,Z5U,1206	04222	12065E104ZAT3A
A2C119	283-5003-00			CAP,FXD,CER:MLC;0.01UF,10%,50V,X7R,1206	TK2058	C3216X7R1H103K-
A2C120	283-5003-00			CAP,FXD,CER:MLC;0.01UF,10%,50V,X7R,1206	TK2058	C3216X7R1H103K-
A2C121	283-5003-00			CAP,FXD,CER:MLC;0.01UF,10%,50V,X7R,1206	TK2058	C3216X7R1H103K-
A2C122	283-5003-00			CAP,FXD,CER:MLC;0.01UF,10%,50V,X7R,1206	TK2058	C3216X7R1H103K-
A2C123	283-5003-00			CAP,FXD,CER:MLC;0.01UF,10%,50V,X7R,1206	TK2058	C3216X7R1H103K-
A2C124	283-5203-00			CAP,FXD,CER:MLC;1000PF,10%,100V,X7R,1206	04222	12061C102KAT1A
A2C125	283-5203-00			CAP,FXD,CER:MLC;1000PF,10%,100V,X7R,1206	04222	12061C102KAT1A
A2C126	283-5189-00			CAP,FXD,CER:MLC;220PF,5%,100V,NPO,1206	04222	12061A221JAT1A
A2C127	283-5201-00			CAP,FXD,CER:MLC;33PF,5%,100V,NPO,1206	04222	12061A330JAT1A
A2C128	283-5006-00			CAP,FXD,CER:MLC;5PF,+/-0.25PF,50V,NPO,1206	TK2058	C3216C0G1H050C-
A2C129	283-5185-00			CAP,FXD,CER:MLC;1000PF,5%,50V,NPO,1206	04222	12065A72JAT1A
A2C130	283-5010-00			CAP,FXD,CER:MLC;0.22UF,10%,25V,X7R,1210	TK2058	C3225X7R1E224K-

Replaceable electrical parts list (Cont.)

Component number	Tektronix part number	Serial no. effective	Serial no. discont'd	Name & description	Mfr. code	Mfr. part number
A2C132	283-5203-00			CAP,FXD,CER:MLC;1000PF,10%,100V,X7R,1206	04222	12061C102KAT1A
A2C133	283-5203-00			CAP,FXD,CER:MLC;1000PF,10%,100V,X7R,1206	04222	12061C102KAT1A
A2C134	283-5202-00			CAP,FXD,CER:MLC;0.022UF,10%,50V,X7R,1206,SMD,8MM	04222	12065C223KAT1A
A2C135	283-5068-00			CAP,FXD,CER:MLC;2200PF,10%,50V,X7R,1206	04222	12065C222KAT1A
A2C137	283-5003-00			CAP,FXD,CER:MLC;0.01UF,10%,50V,X7R,1206	TK2058	C3216X7R1H103K-
A2C158	290-5034-01			CAP,FXD,ALUM:33UF,20%,10V,5.7MM(0.224)	62643	MVK10VC33RME60T
A2C159	283-5098-00			CAP,FXD,CER:MLC;0.1UF,+80%-20%,50V,Z5U,1206	04222	12065E104ZAT3A
A2C160	283-5098-00			CAP,FXD,CER:MLC;0.1UF,+80%-20%,50V,Z5U,1206	04222	12065E104ZAT3A
A2C161	283-5267-00			CAP,FXD,CER:MLC;1UF,+80%-20%,25V,Y5V,1206	04222	12063G105ZAT1A
A2C162	283-5098-00			CAP,FXD,CER:MLC;0.1UF,+80%-20%,50V,Z5U,1206	04222	12065E104ZAT3A
A2C163	283-5106-00			CAP,FXD,CER:MLC;470PF,5%,100V,NPO,1206	04222	12061A471JAT1A
A2C165	283-5006-00			CAP,FXD,CER:MLC;5PF,+/-0.25PF,50V,NPO,1206	TK2058	C3216C0G1H050C-
A2C166	283-5197-00			CAP,FXD,CER:MLC;330PF,5%,100V,NPO,1206	04222	12061A331JAT1A
A2C167	283-5098-00			CAP,FXD,CER:MLC;0.1UF,+80%-20%,50V,Z5U,1206	04222	12065E104ZAT3A
A2C168	283-5098-00			CAP,FXD,CER:MLC;0.1UF,+80%-20%,50V,Z5U,1206	04222	12065E104ZAT3A
A2C169	283-5098-00			CAP,FXD,CER:MLC;0.1UF,+80%-20%,50V,Z5U,1206	04222	12065E104ZAT3A
A2C170	283-5189-00			CAP,FXD,CER:MLC;220PF,5%,100V,NPO,1206	04222	12061A221JAT1A
A2C171	283-5010-00			CAP,FXD,CER:MLC;0.22UF,10%,25V,X7R,1210	TK2058	C3225X7R1E224K-
A2C172	283-5098-00			CAP,FXD,CER:MLC;0.1UF,+80%-20%,50V,Z5U,1206	04222	12065E104ZAT3A
A2C173	283-5098-00			CAP,FXD,CER:MLC;0.1UF,+80%-20%,50V,Z5U,1206	04222	12065E104ZAT3A
A2C174	283-5098-00			CAP,FXD,CER:MLC;0.1UF,+80%-20%,50V,Z5U,1206	04222	12065E104ZAT3A
A2C175	283-5098-00			CAP,FXD,CER:MLC;0.1UF,+80%-20%,50V,Z5U,1206	04222	12065E104ZAT3A
A2C176	283-5265-00			CAP,FXD,CER:MLC;0.0033UF,5%,50V,NPO,1206	04222	12065A332JAT1A
A2C177	283-5106-00			CAP,FXD,CER:MLC;470PF,5%,100V,NPO,1206	04222	12061A471JAT1A
A2C178	283-5189-00			CAP,FXD,CER:MLC;220PF,5%,100V,NPO,1206	04222	12061A221JAT1A
A2C179	283-5197-00			CAP,FXD,CER:MLC;330PF,5%,100V,NPO,1206	04222	12061A331JAT1A
A2C180	283-5189-00			CAP,FXD,CER:MLC;220PF,5%,100V,NPO,1206	04222	12061A221JAT1A
A2C183	283-5098-00			CAP,FXD,CER:MLC;0.1UF,+80%-20%,50V,Z5U,1206	04222	12065E104ZAT3A
A2C184	283-5098-00			CAP,FXD,CER:MLC;0.1UF,+80%-20%,50V,Z5U,1206	04222	12065E104ZAT3A
A2C185	283-5098-00			CAP,FXD,CER:MLC;0.1UF,+80%-20%,50V,Z5U,1206	04222	12065E104ZAT3A
A2C186	283-5098-00			CAP,FXD,CER:MLC;0.1UF,+80%-20%,50V,Z5U,1206	04222	12065E104ZAT3A
A2C187	283-5098-00			CAP,FXD,CER:MLC;0.1UF,+80%-20%,50V,Z5U,1206	04222	12065E104ZAT3A
A2C188	283-5098-00			CAP,FXD,CER:MLC;0.1UF,+80%-20%,50V,Z5U,1206	04222	12065E104ZAT3A
A2C189	283-5098-00			CAP,FXD,CER:MLC;0.1UF,+80%-20%,50V,Z5U,1206	04222	12065E104ZAT3A
A2C190	283-5098-00			CAP,FXD,CER:MLC;0.1UF,+80%-20%,50V,Z5U,1206	04222	12065E104ZAT3A
A2C191	283-5098-00			CAP,FXD,CER:MLC;0.1UF,+80%-20%,50V,Z5U,1206	04222	12065E104ZAT3A
A2C192	283-5098-00			CAP,FXD,CER:MLC;0.1UF,+80%-20%,50V,Z5U,1206	04222	12065E104ZAT3A
A2C193	283-5098-00			CAP,FXD,CER:MLC;0.1UF,+80%-20%,50V,Z5U,1206	04222	12065E104ZAT3A

Replaceable electrical parts list (Cont.)

Component number	Tektronix part number	Serial no. effective	Serial no. discont'd	Name & description	Mfr. code	Mfr. part number
A2C194	283-5098-00			CAP,FXD,CER:MLC;0.1UF,+80%-20%,50V,Z5U,1206	04222	12065E104ZAT3A
A2C195	283-5098-00			CAP,FXD,CER:MLC;0.1UF,+80%-20%,50V,Z5U,1206	04222	12065E104ZAT3A
A2C196	283-5098-00			CAP,FXD,CER:MLC;0.1UF,+80%-20%,50V,Z5U,1206	04222	12065E104ZAT3A
A2C197	283-5098-00			CAP,FXD,CER:MLC;0.1UF,+80%-20%,50V,Z5U,1206	04222	12065E104ZAT3A
A2C198	283-5098-00			CAP,FXD,CER:MLC;0.1UF,+80%-20%,50V,Z5U,1206	04222	12065E104ZAT3A
A2C199	283-5098-00			CAP,FXD,CER:MLC;0.1UF,+80%-20%,50V,Z5U,1206	04222	12065E104ZAT3A
A2C200	283-5098-00			CAP,FXD,CER:MLC;0.1UF,+80%-20%,50V,Z5U,1206	04222	12065E104ZAT3A
A2C201	283-5098-00			CAP,FXD,CER:MLC;0.1UF,+80%-20%,50V,Z5U,1206	04222	12065E104ZAT3A
A2C202	283-5098-00			CAP,FXD,CER:MLC;0.1UF,+80%-20%,50V,Z5U,1206	04222	12065E104ZAT3A
A2C203	283-5098-00			CAP,FXD,CER:MLC;0.1UF,+80%-20%,50V,Z5U,1206	04222	12065E104ZAT3A
A2C204	283-5098-00			CAP,FXD,CER:MLC;0.1UF,+80%-20%,50V,Z5U,1206	04222	12065E104ZAT3A
A2C205	283-5098-00			CAP,FXD,CER:MLC;0.1UF,+80%-20%,50V,Z5U,1206	04222	12065E104ZAT3A
A2C206	283-5098-00			CAP,FXD,CER:MLC;0.1UF,+80%-20%,50V,Z5U,1206	04222	12065E104ZAT3A
A2C207	283-5098-00			CAP,FXD,CER:MLC;0.1UF,+80%-20%,50V,Z5U,1206	04222	12065E104ZAT3A
A2C208	283-5098-00			CAP,FXD,CER:MLC;0.1UF,+80%-20%,50V,Z5U,1206	04222	12065E104ZAT3A
A2C209	283-5098-00			CAP,FXD,CER:MLC;0.1UF,+80%-20%,50V,Z5U,1206	04222	12065E104ZAT3A
A2C210	283-5098-00			CAP,FXD,CER:MLC;0.1UF,+80%-20%,50V,Z5U,1206	04222	12065E104ZAT3A
A2C211	283-5098-00			CAP,FXD,CER:MLC;0.1UF,+80%-20%,50V,Z5U,1206	04222	12065E104ZAT3A
A2C212	283-5098-00			CAP,FXD,CER:MLC;0.1UF,+80%-20%,50V,Z5U,1206	04222	12065E104ZAT3A
A2C213	283-5098-00			CAP,FXD,CER:MLC;0.1UF,+80%-20%,50V,Z5U,1206	04222	12065E104ZAT3A
A2C214	283-5098-00			CAP,FXD,CER:MLC;0.1UF,+80%-20%,50V,Z5U,1206	04222	12065E104ZAT3A
A2C215	283-5098-00			CAP,FXD,CER:MLC;0.1UF,+80%-20%,50V,Z5U,1206	04222	12065E104ZAT3A
A2C216	283-5098-00			CAP,FXD,CER:MLC;0.1UF,+80%-20%,50V,Z5U,1206	04222	12065E104ZAT3A
A2C217	283-5098-00			CAP,FXD,CER:MLC;0.1UF,+80%-20%,50V,Z5U,1206	04222	12065E104ZAT3A
A2C218	283-5098-00			CAP,FXD,CER:MLC;0.1UF,+80%-20%,50V,Z5U,1206	04222	12065E104ZAT3A
A2C219	283-5098-00			CAP,FXD,CER:MLC;0.1UF,+80%-20%,50V,Z5U,1206	04222	12065E104ZAT3A
A2C220	283-5098-00			CAP,FXD,CER:MLC;0.1UF,+80%-20%,50V,Z5U,1206	04222	12065E104ZAT3A
A2C221	283-5098-00			CAP,FXD,CER:MLC;0.1UF,+80%-20%,50V,Z5U,1206	04222	12065E104ZAT3A
A2C222	283-5098-00			CAP,FXD,CER:MLC;0.1UF,+80%-20%,50V,Z5U,1206	04222	12065E104ZAT3A
A2C223	283-5098-00			CAP,FXD,CER:MLC;0.1UF,+80%-20%,50V,Z5U,1206	04222	12065E104ZAT3A
A2C224	283-5098-00			CAP,FXD,CER:MLC;0.1UF,+80%-20%,50V,Z5U,1206	04222	12065E104ZAT3A
A2C225	283-5098-00			CAP,FXD,CER:MLC;0.1UF,+80%-20%,50V,Z5U,1206	04222	12065E104ZAT3A
A2C228	290-5034-01			CAP,FXD,ALUM:33UF,20%,10V,5.7MM(0.224)	62643	MVK10VC33RME60T
A2C229	281-5016-00			CAP,VAR,CER:1.5-10PF,25V,N400+/-50PPM/CO	04222	CTZ3E-10B-W1P
A2C230	281-5012-00			CAP,VAR,CER:5-40PF,25V,TOP-ADJ	04222	CTZ3S-40C-W5
A2C231	283-5098-00			CAP,FXD,CER:MLC;0.1UF,+80%-20%,50V,Z5U,1206	04222	12065E104ZAT3A
A2C232	283-5003-00			CAP,FXD,CER:MLC;0.01UF,10%,50V,X7R,1206	TK2058	C3216X7R1H103K-
A2C233	283-5203-00			CAP,FXD,CER:MLC;1000PF,10%,100V,X7R,1206	04222	12061C102KAT1A

Replaceable electrical parts list (Cont.)

Component number	Tektronix part number	Serial no. effective	Serial no. discont'd	Name & description	Mfr. code	Mfr. part number
A2C234	283-5195-00			CAP,FXD,CER:MLC;10PF,5%,100V ,NPO,1206	04222	12061A70JAT1A
A2C235	283-5107-00			CAP,FXD,CER:MLC;22PF,5%,100V,NPO,1206	04222	12061A220JAT1A
A2C236	281-5016-00			CAP,VAR,CER:1.5-10PF,25V,N400+/-500PPM/C	04222	CTZ3E-10B-W1P
A2C237	281-5012-00			CAP,VAR,CER:5-40PF,25V, TOP-ADJ	04222	CTZ3S-40C-W5
A2C238	283-5098-00			CAP,FXD,CER:MLC;0.1UF,+80%-20%,50V,Z5U,1206	04222	12065E104ZAT3A
A2C239	283-5003-00			CAP,FXD,CER:MLC;0.01UF,10%,50V,X7R,1206	TK2058	C3216X7R1H103K-
A2C240	283-5203-00			CAP,FXD,CER:MLC;1000PF,10%,100V,X7R,1206	04222	12061C102KAT1A
A2C241	283-5195-00			CAP,FXD,CER:MLC;10PF,5%,100V ,NPO,1206	04222	12061A70JAT1A
A2C242	283-5107-00			CAP,FXD,CER:MLC;22PF,5%,100V,NPO,1206	04222	12061A220JAT1A
A2C243	281-5016-00			CAP,VAR,CER:1.5-10PF,25V,N400+/-500PPM/C	04222	CTZ3E-10B-W1P
A2C244	281-5012-00			CAP,VAR,CER:5-40PF,25V TOP-ADJ	04222	CTZ3S-40C-W5
A2C245	283-5098-00			CAP,FXD,CER:MLC;0.1UF,+80%-20%,50V,Z5U,1206	04222	12065E104ZAT3A
A2C246	283-5003-00			CAP,FXD,CER:MLC;0.01UF,10%,50V,X7R,1206	TK2058	C3216X7R1H103K-
A2C247	283-5203-00			CAP,FXD,CER:MLC;1000PF,10%,100V,X7R,1206	04222	12061C102KAT1A
A2C248	283-5195-00			CAP,FXD,CER:MLC;10PF,5%,100V ,NPO,1206	04222	12061A70JAT1A
A2C249	283-5107-00			CAP,FXD,CER:MLC;22PF,5%,100V,NPO,1206	04222	12061A220JAT1A
A2C250	283-5003-00			CAP,FXD,CER:MLC;0.01UF,10%,50V,X7R,1206	TK2058	C3216X7R1H103K-
A2C251	283-5003-00			CAP,FXD,CER:MLC;0.01UF,10%,50V,X7R,1206	TK2058	C3216X7R1H103K-
A2C252	283-5003-00			CAP,FXD,CER:MLC;0.01UF,10%,50V,X7R,1206	TK2058	C3216X7R1H103K-
A2C253	283-5003-00			CAP,FXD,CER:MLC;0.01UF,10%,50V,X7R,1206	TK2058	C3216X7R1H103K-
A2C254	283-5185-00			CAP,FXD,CER:MLC;1000PF,5%,50V,NPO,1206	04222	12065A72JAT1A
A2C255	283-5098-00			CAP,FXD,CER:MLC;0.1UF,+80%-20%,50V,Z5U,1206	04222	12065E104ZAT3A
A2C256	283-5098-00			CAP,FXD,CER:MLC;0.1UF,+80%-20%,50V,Z5U,1206	04222	12065E104ZAT3A
A2C257	283-5098-00			CAP,FXD,CER:MLC;0.1UF,+80%-20%,50V,Z5U,1206	04222	12065E104ZAT3A
A2C258	283-5003-00			CAP,FXD,CER:MLC;0.01UF,10%,50V,X7R,1206	TK2058	C3216X7R1H103K-
A2C259	283-5003-00			CAP,FXD,CER:MLC;0.01UF,10%,50V,X7R,1206	TK2058	C3216X7R1H103K-
A2C260	283-5003-00			CAP,FXD,CER:MLC;0.01UF,10%,50V,X7R,1206	TK2058	C3216X7R1H103K-
A2C261	283-5203-00			CAP,FXD,CER:MLC;1000PF,10%,100V,X7R,1206	04222	12061C102KAT1A
A2C262	283-5203-00			CAP,FXD,CER:MLC;1000PF,10%,100V,X7R,1206	04222	12061C102KAT1A
A2C263	283-5203-00			CAP,FXD,CER:MLC;1000PF,10%,100V,X7R,1206	04222	12061C102KAT1A
A2C264	283-5203-00			CAP,FXD,CER:MLC;1000PF,10%,100V,X7R,1206	04222	12061C102KAT1A
A2C300	283-5267-00			CAP,FXD,CER:MLC;1UF,+80%-20%,25V,Y5V,1206,SMD	04222	12063G105ZAT4A
A2C301	283-5195-00			CAP,FXD,CER:MLC;10PF,5%,100V ,NPO,1206,SMD	04222	12061A100JAT1A
A2C302	283-5195-00			CAP,FXD,CER:MLC;10PF,5%,100V ,NPO,1206,SMD	04222	12061A100JAT1A
A2C305	283-5203-00			CAP,FXD,CER:MLC;1000PF,10%,100V,X7R,1206,SMD	04222	12061C102KAT1A
A2C305	283-5203-00			CAP,FXD,CER:MLC;1000PF,10%,100V,X7R,1206,SMD	04222	12061C102KAT1A
A2C500	283-5098-00			CAP,FXD,CER:MLC;0.1UF,+80%-20%,50V,Z5U,1206	04222	12065E104ZAT3A
A2C501	283-5098-00			CAP,FXD,CER:MLC;0.1UF,+80%-20%,50V,Z5U,1206	04222	12065E104ZAT3A

Replaceable electrical parts list (Cont.)

Component number	Tektronix part number	Serial no. effective	Serial no. discont'd	Name & description	Mfr. code	Mfr. part number
A2C502	283-5098-00			CAP,FXD,CER:MLC;0.1UF,+80%-20%,50V,Z5U,1206	04222	12065E104ZAT3A
A2C503	283-5098-00			CAP,FXD,CER:MLC;0.1UF,+80%-20%,50V,Z5U,1206	04222	12065E104ZAT3A
A2C504	283-5098-00			CAP,FXD,CER:MLC;0.1UF,+80%-20%,50V,Z5U,1206	04222	12065E104ZAT3A
A2C505	283-5098-00			CAP,FXD,CER:MLC;0.1UF,+80%-20%,50V,Z5U,1206	04222	12065E104ZAT3A
A2C506	283-5098-00			CAP,FXD,CER:MLC;0.1UF,+80%-20%,50V,Z5U,1206	04222	12065E104ZAT3A
A2C507	290-5034-01			CAP,FXD,ALUM:33UF,20%,10V,5.7MM(0.224)	62643	MVK10VC33RME60T
A2C508	283-5003-00			CAP,FXD,CER:MLC;0.01UF,10%,50V,X7R,1206	TK2058	C3216X7R1H103K-
A2C509	283-5098-00			CAP,FXD,CER:MLC;0.1UF,+80%-20%,50V,Z5U,1206	04222	12065E104ZAT3A
A2C510	283-5098-00			CAP,FXD,CER:MLC;0.1UF,+80%-20%,50V,Z5U,1206	04222	12065E104ZAT3A
A2C511	283-5098-00			CAP,FXD,CER:MLC;0.1UF,+80%-20%,50V,Z5U,1206	04222	12065E104ZAT3A
A2C512	283-5098-00			CAP,FXD,CER:MLC;0.1UF,+80%-20%,50V,Z5U,1206	04222	12065E104ZAT3A
A2C513	283-5098-00			CAP,FXD,CER:MLC;0.1UF,+80%-20%,50V,Z5U,1206	04222	12065E104ZAT3A
A2C514	283-5098-00			CAP,FXD,CER:MLC;0.1UF,+80%-20%,50V,Z5U,1206	04222	12065E104ZAT3A
A2C515	283-5098-00			CAP,FXD,CER:MLC;0.1UF,+80%-20%,50V,Z5U,1206	04222	12065E104ZAT3A
A2C550	283-5003-00			CAP,FXD,CER:MLC;0.01UF,10%,50V,X7R,1206	TK2058	C3216X7R1H103K-
A2C551	283-5098-00			CAP,FXD,CERAMIC:MLC,0.1UF,+80%-20%,50V,Z5U,1206,SMD	04222	12065E104ZAT3A
A2C552	283-5098-00			CAP,FXD,CERAMIC:MLC,0.1UF,+80%-20%,50V,Z5U,1206,SMD	04222	12065E104ZAT3A
A2CR1	152-5062-00			DIO,SIG:ULTRA FAST;100V,0.74VF,4NS,2.0PF,COM-ANODE	27014	MMBD1205
A2CR2	152-5062-00			DIO,SIG:ULTRA FAST;100V,0.74VF,4NS,2.0PF,COM-ANODE	27014	MMBD1205
A2CR3	152-5018-00			DIODE,SIG:ULTRA FAST;100V,0.74VF,4NS,2.0PF,SER-PAIR	27014	MMBD1203
A2CR4	152-5018-00			DIODE,SIG:ULTRA FAST;100V,0.74VF,4NS,2.0PF,SER-PAIR	27014	MMBD1203
A2CR5	152-5018-00			DIODE,SIG:ULTRA FAST;100V,0.74VF,4NS,2.0PF,SER-PAIR	27014	MMBD1203
A2CR6	152-5018-00			DIODE,SIG:ULTRA FAST;100V,0.74VF,4NS,2.0PF,SER-PAIR	27014	MMBD1203
A2CR7	152-5018-00			DIODE,SIG:ULTRA FAST;100V,0.74VF,4NS,2.0PF,SER-PAIR	27014	MMBD1203
A2CR8	152-5018-00			DIODE,SIG:ULTRA FAST;100V,0.74VF,4NS,2.0PF,SER-PAIR	27014	MMBD1203
A2CR9	152-5018-00			DIODE,SIG:ULTRA FAST;100V,0.74VF,4NS,2.0PF,SER-PAIR	27014	MMBD1203
A2CR10	152-5018-00			DIODE,SIG:ULTRA FAST;100V,0.74VF,4NS,2.0PF,SER-PAIR	27014	MMBD1203
A2CR28	152-5010-00			DIODE,SIG:VVC;30V,29PF,C3/25=5.75	0LUA3	BBY40TRL
A2CR34	152-5010-00			DIODE,SIG:VVC;30V,29PF,C3/25=5.75	0LUA3	BBY40TRL
A2CR35	152-5018-00			DIODE,SIG:ULTRA FAST;100V,0.74VF,4NS,2.0PF,SER-PAIR	27014	MMBD1203
A2CR36	152-5047-00			DIODE,SIG:ULTRA FAST;100V,0.74VF,4NS,2.0PF,COM-CATH	27014	MMBD1204
A2CR37	152-5047-00			DIODE,SIG:ULTRA FAST;100V,0.74VF,4NS,2.0PF,COM-CATH	27014	MMBD1204
A2CR38	152-5018-00			DIODE,SIG:ULTRA FAST;100V,0.74VF,4NS,2.0PF,SER-PAIR	27014	MMBD1203
A2CR39	152-5018-00			DIODE,SIG:ULTRA FAST;100V,0.74VF,4NS,2.0PF,SER-PAIR	27014	MMBD1203
A2CR40	152-5047-00			DIODE,SIG:ULTRA FAST;100V,0.74VF,4NS,2.0PF,COM-CATH	27014	MMBD1204
A2CR41	152-0843-00			DIODE,SIG:SCHTKY;SER-PAIR,20V,410MV,1.3PF	50434	HSMS-2812-T31
A2DS1	150-5009-00			DIO,OPTO:LED;HI-EFFIC RED,626NM,3.4MCD AT IF=10MA	50434	HLMP-6305-021
A2DS2	150-5009-00			DIO,OPTO:LED;HI-EFFIC RED,626NM,3.4MCD AT IF=10MA	50434	HLMP-6305-021

Replaceable electrical parts list (Cont.)

Component number	Tektronix part number	Serial no. effective	Serial no. discont'd	Name & description	Mfr. code	Mfr. part number
A2DS3	150-5009-00			DIO,OPTO:LED;HI-EFFIC RED,626NM,3.4MCD AT IF=10MA	50434	HLMP-6305-021
A2DS4	150-5009-00			DIO,OPTO:LED;HI-EFFIC RED,626NM,3.4MCD AT IF=10MA	50434	HLMP-6305-021
A2E1	108-5084-00			EMI,SUPPRESSION:FERRITE BEAD,52 OHM,+/-25% @100MHZ,DCR=0.3 OHM,IMAX=400 MA,CHIP,8MM T&R	TK2058	HF70ACB322513T
A2E2	108-5082-00			EMI,SUPPRESSION:FERRITE BEAD,120 OHM,+/-25% @100MHZ,DCR=0.4 OHM,IMAX=300 MA,CHIP,12MM T&R	TK2058	HF70ACB453215T
A2E3	108-5082-00			EMI,SUPPRESSION:FERRITE BEAD,120 OHM,+/-25% @100MHZ,DCR=0.4 OHM,IMAX=300 MA,CHIP,12MM T&R	TK2058	HF70ACB453215T
A2E4	108-5082-00			EMI,SUPPRESSION:FERRITE BEAD,120 OHM,+/-25% @100MHZ,DCR=0.4 OHM,IMAX=300 MA,CHIP,12MM T&R	TK2058	HF70ACB453215T
A2E5	108-5082-00			EMI,SUPPRESSION:FERRITE BEAD,120 OHM,+/-25% @100MHZ,DCR=0.4 OHM,IMAX=300 MA,CHIP,12MM T&R	TK2058	HF70ACB453215T
A2E6	276-0269-00			CORE,EM:TOROID;FERRITE,U(REF)=850 (100KHZ), Z=21.1 OHM 20% (100MHZ)	33062	21-069-J
A2E7	276-0269-00			CORE,EM:TOROID;FERRITE,U(REF)=850 (100KHZ), Z=21.1 OHM 20% (100MHZ)	33062	21-069-J
A2J1	131-3323-00			CONN,HDR:PCB;MALE,STR,2 X 20,0.1 CTR,0.365D	22526	66506-025
A2J2	131-3323-00			CONN,HDR:PCB;MALE,STR,2 X 20,0.1 CTR,0.365D	22526	66506-025
A2J3	131-3364-00			CONN,HDR:PCB;MALE,STR,2 X 17,0.1 CTR,0.365D	53387	2534-6002UB
A2J4	131-3323-00			CONN,HDR:PCB;MALE,STR,2 X 20,0.1 CTR,0.365D	22526	66506-025
A2J5	131-3323-00			CONN,HDR:PCB;MALE,STR,2 X 20,0.1 CTR,0.365D	22526	66506-025
A2J6	131-3520-00			CONN,HDR:PCB;MALE,STR,2 X 5,0.1 CTR,0.365 H X 0.112 TAIL,SHRD/4 SIDES,MIL PLZ,30 GOLD	53387	2510-6002UB
A2J8	131-3364-00			CONN,HDR:PCB;MALE,STR,2 X 17,0.1 CTR,0.365D	53387	2534-6002UB
A2J9	131-3520-00			CONN,HDR:PCB;MALE,STR,2 X 5,0.1 CTR,0.365 H X 0.112 TAIL,SHRD/4 SIDES,MIL PLZ,30 GOLD	53387	2510-6002UB
A2J10	131-3270-00			CONN,HDR:PCB;MALE,STR,1 X 2,0.1 CTR,0.295 MLG X 0.140 TAIL,TIN,PLZ WALL,W/FRICTION LOCK,	00779	640456-2
A2J11	131-4183-00			CONN,HDR:PCB;MALE,STR,2 X 7,0.1 CTR,0.365 H X 0.112 TAIL,SHRD/4 SIDES,CTR PLZ,30 GOLD	53387	2514-6002UB
A2J12	131-4530-00			CONN,HDR:PCB;MALE,STR,1 X 3,0.1 CTR,0.230 MLG X 0.120 TAIL,30GOLD,BD RETENTION	00779	104344-1
A2J13	131-4530-00			CONN,HDR:PCB;MALE,STR,1 X 3,0.1 CTR,0.230 MLG X 0.120 TAIL,30GOLD,BD RETENTION	00779	104344-1
A2J17	131-0391-00			CONN,RF JACK:SMB;MALE,STR,PCB,GOLD/GOLD,0.293 H X 0.155 TAIL,3/0.045 SQ TAIL 0.038 DIA CTR COND,0.2 SQ PCB,0.312 HEX	24931	32JR105-1
A2J18	131-0391-00			CONN,RF JACK:SMB;MALE,STR,PCB,GOLD/GOLD,0.293 H X 0.155 TAIL,3/0.045 SQ TAIL 0.038 DIA CTR COND,0.2 SQ PCB,0.312 HEX	24931	32JR105-1
A2J19	131-5841-00			CONN,HDR:PCB;MALE,STR,2 X 4,0.1 CTR,0.318 MLG X 0.112 TAIL,30GOLD	53387	2408-6222TB
A2J21	131-3520-00		671-3124-02	CONN,HDR:PCB;MALE,STR,2 X 5,0.1 CTR,0.365 H X 0.112 TAIL,SHRD/4 SIDES,MIL PLZ,30 GOLD	53387	2510-6002UB
A2J23	131-3074-00	671-3124-05		PCB,MALE,STR,2 X 10,0.1 CTR,0.318 MLG X 0.110 TAIL,30 GOLD	22526	65805-120

Replaceable Electrical Parts

Replaceable electrical parts list (Cont.)

Component number	Tektronix part number	Serial no. effective	Serial no. discont'd	Name & description	Mfr. code	Mfr. part number
A2J24	131-6003-00	671-3124-05		CONN,HDR,PCB;MALE,STR, 1 X 8, 0.1 CTR,0,30 GOLD	53387	2408-6112TB
A2J25	131-6003-00	671-3124-05		CONN,HDR,PCB;MALE,STR, 1 X 8, 0.1 CTR,30 GOLD	53387	2408-6112TB
A2J26	131-3074-00	671-3124-05		PCB,MALE,STR,2 X 10,0.1 CTR,0.318 MLG X 0.110 TAIL,30 GOLD	22526	65805-120
A2J27	131-3392-00	671-3124-05		CONN,HDR,PCB;MALE,STR, 1 X 10,0.1 CTR,BD RETENTION	060D9	ORDER BY DESCRIPTION
A2J28	131-3074-00	671-3124-05		PCB,MALE,STR,2 X 10,0.1 CTR,0.318 MLG X 0.110 TAIL,30 GOLD	22526	65805-120
A2J29	131-3074-00	671-3124-05		PCB,MALE,STR,2 X 10,0.1 CTR,0.318 MLG X 0.110 TAIL,30 GOLD	22526	65805-120
A2J30	131-3392-00	671-3124-05		CONN,HDR,PCB;MALE,STR, 1 X 10,0.1 CTR,0.230 MLG X 0.120 TAIL,30 GOLD,BD RETENTION	060D9	ORDER BY DESCRIPTION
A2J31	131-6003-00	671-3124-05		CONN,HDR,PCB;MALE,STR, 1 X 8, 0.1 CTR,30 GOLD	53387	2408-6112TB
A2L1	108-1263-00			INDUCTOR,FXD:POWER;10UH,10%,SRF>19MHZ,BOBBIN	TK2058	TSL0707-100K1R9
A2L2	108-0733-00			INDUCTOR,FXD:CUSTOM,SIGNAL;117NH,10%	OJR03	108-0733-00
A2L5	108-5120-00			INDUCTOR,FXD:SIGNAL;56UH,10%,	09969	IMC-1812-56UH-1
A2L6	108-5074-00			INDUCTOR,FXD:SIGNAL;3.9UH,10%	02113	1008CS-392XKB(A
A2L7	108-5074-00			INDUCTOR,FXD:SIGNAL;3.9UH,10%	02113	1008CS-392XKB(A
A2L8	108-5120-00			INDUCTOR,FXD:SIGNAL;56UH,10%	09969	IMC-1812-56UH-1
A2L9	108-5121-00			INDUCTOR,FXD:SIGNAL,SHIELDED;560NH,IDC<440 MA,RDC<0.51 OHM,Q>50,SRF>180 MHZ	TK2058	ACL3225S-R56KT
A2L10	108-5121-00			INDUCTOR,FXD:SIGNAL,SHIELDED;560NH,IDC<440 MA,RDC<0.51 OHM,Q>50,SRF>180 MHZ	TK2058	ACL3225S-R56KT
A2L11	108-5121-00			INDUCTOR,FXD:SIGNAL,SHIELDED;560NH,IDC<440 MA,RDC<0.51 OHM,Q>50,SRF>180 MHZ	TK2058	ACL3225S-R56KT
A2L12	108-5121-00			INDUCTOR,FXD:SIGNAL,SHIELDED;560NH,IDC<440 MA,RDC<0.51 OHM,Q>50,SRF>180 MHZ	TK2058	ACL3225S-R56KT
A2L13	108-5121-00			INDUCTOR,FXD:SIGNAL,SHIELDED;560NH,IDC<440 MA,RDC<0.51 OHM,Q>50,SRF>180 MHZ	TK2058	ACL3225S-R56KT
A2L14	108-5121-00			INDUCTOR,FXD:SIGNAL,SHIELDED;560NH,IDC<440 MA,RDC<0.51 OHM,Q>50,SRF>180 MHZ	TK2058	ACL3225S-R56KT
A2P1	131-0993-02			BUS,CONDUCTOR:SHUNT ASSEMBLY,RED	00779	1-850100-O
A2P2	131-0993-02			BUS,CONDUCTOR:SHUNT ASSEMBLY,RED	00779	1-850100-O
A2Q3	151-5072-00			XSTR,PWR:MOS,N-CH;50V,0.045 OHM,LOGIC	17856	SMD25N05-45L
A2Q5	151-5034-00			XSTR,SIG:BIPOLAR,NPN;14V,50MA,1.5GHZ,AMPL	62104	NE73433-T1B (2S
A2Q6	151-5008-00			XSTR,SIG:BIPOLAR,NPN;12V,70MA,3.0GHZ,AMPL	62104	NE02133-T1B (2S
A2Q7	151-5034-00			XSTR,SIG:BIPOLAR,NPN;14V,50MA,1.5GHZ,AMPL	62104	NE73433-T1B (2S
A2Q8	151-5034-00			XSTR,SIG:BIPOLAR,NPN;14V,50MA,1.5GHZ,AMPL	62104	NE73433-T1B (2S
A2Q9	151-5034-00			XSTR,SIG:BIPOLAR,NPN;14V,50MA,1.5GHZ,AMPL	62104	NE73433-T1B (2S
A2R1	321-5030-00			RES,FXD:THICK FILM;10.0K OHM,1%,0.125W,TC=100 PPM	50139	BCK1002FT
A2R6	321-5026-00			RES,FXD:THICK FILM;4.75K OHM,1%,0.125W,TC=100 PPM	50139	BCK4751FT
A2R7	321-5030-00			RES,FXD:THICK FILM;10.0K OHM,1%,0.125W,TC=100 PPM	50139	BCK1002FT
A2R8	321-5030-00			RES,FXD:THICK FILM;10.0K OHM,1%,0.125W,TC=100 PPM	50139	BCK1002FT
A2R9	321-5030-00			RES,FXD:THICK FILM;10.0K OHM,1%,0.125W,TC=100 PPM	50139	BCK1002FT

Replaceable electrical parts list (Cont.)

Component number	Tektronix part number	Serial no. effective	Serial no. discont'd	Name & description	Mfr. code	Mfr. part number
A2R10	321-5030-00			RES,FXD:THICK FILM;10.0K OHM,1%,0.125W,TC=100 PPM	50139	BCK1002FT
A2R11	321-5030-00			RES,FXD:THICK FILM;10.0K OHM,1%,0.125W,TC=100 PPM	50139	BCK1002FT
A2R12	321-5030-00			RES,FXD:THICK FILM;10.0K OHM,1%,0.125W,TC=100 PPM	50139	BCK1002FT
A2R18	321-5000-00			RES,FXD:THICK FILM;10 OHM,1%,0.125W,TC=100 PPM	59124	RK73H2B10R0FT
A2R19	321-5000-00			RES,FXD:THICK FILM;10 OHM,1%,0.125W,TC=100 PPM	59124	RK73H2B10R0FT
A2R23	321-5030-00			RES,FXD:THICK FILM;10.0K OHM,1%,0.125W,TC=100 PPM	50139	BCK1002FT
A2R24	321-5030-00			RES,FXD:THICK FILM;10.0K OHM,1%,0.125W,TC=100 PPM	50139	BCK1002FT
A2R25	321-5030-00			RES,FXD:THICK FILM;10.0K OHM,1%,0.125W,TC=100 PPM	50139	BCK1002FT
A2R26	321-5030-00			RES,FXD:THICK FILM;10.0K OHM,1%,0.125W,TC=100 PPM	50139	BCK1002FT
A2R27	321-5030-00			RES,FXD:THICK FILM;10.0K OHM,1%,0.125W,TC=100 PPM	50139	BCK1002FT
A2R28	321-5030-00			RES,FXD:THICK FILM;10.0K OHM,1%,0.125W,TC=100 PPM	50139	BCK1002FT
A2R29	321-5030-00			RES,FXD:THICK FILM;10.0K OHM,1%,0.125W,TC=100 PPM	50139	BCK1002FT
A2R30	321-5030-00			RES,FXD:THICK FILM;10.0K OHM,1%,0.125W,TC=100 PPM	50139	BCK1002FT
A2R31	321-5030-00			RES,FXD:THICK FILM;10.0K OHM,1%,0.125W,TC=100 PPM	50139	BCK1002FT
A2R32	321-5030-00			RES,FXD:THICK FILM;10.0K OHM,1%,0.125W,TC=100 PPM	50139	BCK1002FT
A2R33	321-5030-00			RES,FXD:THICK FILM;10.0K OHM,1%,0.125W,TC=100 PPM	50139	BCK1002FT
A2R34	321-5030-00			RES,FXD:THICK FILM;10.0K OHM,1%,0.125W,TC=100 PPM	50139	BCK1002FT
A2R35	321-5030-00			RES,FXD:THICK FILM;10.0K OHM,1%,0.125W,TC=100 PPM	50139	BCK1002FT
A2R36	321-5030-00			RES,FXD:THICK FILM;10.0K OHM,1%,0.125W,TC=100 PPM	50139	BCK1002FT
A2R37	321-5030-00			RES,FXD:THICK FILM;10.0K OHM,1%,0.125W,TC=100 PPM	50139	BCK1002FT
A2R38	321-5030-00			RES,FXD:THICK FILM;10.0K OHM,1%,0.125W,TC=100 PPM	50139	BCK1002FT
A2R39	321-5030-00			RES,FXD:THICK FILM;10.0K OHM,1%,0.125W,TC=100 PPM	50139	BCK1002FT
A2R40	321-5030-00			RES,FXD:THICK FILM;10.0K OHM,1%,0.125W,TC=100 PPM	50139	BCK1002FT
A2R41	321-5030-00			RES,FXD:THICK FILM;10.0K OHM,1%,0.125W,TC=100 PPM	50139	BCK1002FT
A2R42	321-5030-00			RES,FXD:THICK FILM;10.0K OHM,1%,0.125W,TC=100 PPM	50139	BCK1002FT
A2R43	321-5029-00			RES,FXD:THICK FILM;8.25K OHM,1%,0.125W,TC=100 PPM	50139	BCK8251FT
A2R44	321-5027-00			RES,FXD:THICK FILM;5.62K OHM,1%,0.125W,TC=100 PPM	50139	BCK5621FT
A2R45	321-5027-00			RES,FXD:THICK FILM;5.62K OHM,1%,0.125W,TC=100 PPM	50139	BCK5621FT
A2R46	321-5024-00			RES,FXD:THICK FILM;3.32K OHM,1%,0.125W,TC=100 PPM	50139	BCK3321FT
A2R47	321-5034-00			RES,FXD:THICK FILM;22.1K OHM,1%,0.125W,TC=100 PPM	50139	BCK2212FT
A2R48	321-5012-00			RES,FXD:THICK FILM;332 OHM,1%,0.125W,TC=100	50139	BCK3320FT
A2R49	321-5014-00			RES,FXD:THICK FILM;475 OHM,1%,0.125W,TC=100	50139	BCK4750FT
A2R50	321-5012-00			RES,FXD:THICK FILM;332 OHM,1%,0.125W,TC=100	50139	BCK3320FT
A2R51	321-5014-00			RES,FXD:THICK FILM;475 OHM,1%,0.125W,TC=100	50139	BCK4750FT
A2R52	321-5018-00			RES,FXD:THICK FILM;1.0K OHM,1%,0.125W,TC=100 PPM	50139	BCK1001FT
A2R53	321-5018-00			RES,FXD:THICK FILM;1.0K OHM,1%,0.125W,TC=100 PPM	50139	BCK1001FT
A2R54	321-5030-00			RES,FXD:THICK FILM;10.0K OHM,1%,0.125W,TC=100 PPM	50139	BCK1002FT
A2R55	321-5030-00		671-3124-05	RES,FXD:THICK FILM;10.0K OHM,1%,0.125W,TC=100 PPM	50139	BCK1002FT

Replaceable electrical parts list (Cont.)

Component number	Tektronix part number	Serial no. effective	Serial no. discont'd	Name & description	Mfr. code	Mfr. part number
A2R55	321-5018-00	671-3124-06		RES,FXD:THICK FILM;1.0K OHM,1%,0.125W,TC=100 PPM	50139	BCK1001FT
A2R56	321-5030-00		671-3124-05	RES,FXD:THICK FILM;1.0K OHM,1%,0.125W,TC=100 PPM	50139	BCK1002FT
A2R56	321-5018-00	671-3124-06		RES,FXD:THICK FILM;1.0K OHM,1%,0.125W,TC=100 PPM	50139	BCK1001FT
A2R57	321-5014-00			RES,FXD:THICK FILM;475 OHM,1%,0.125W,TC=100	50139	BCK4750FT
A2R58	321-5014-00			RES,FXD:THICK FILM;475 OHM,1%,0.125W,TC=100	50139	BCK4750FT
A2R59	321-5008-00			RES,FXD:THICK FILM;150 OHM,1%,0.125W,TC=100	50139	BCK1500FT
A2R60	321-5010-00			RES,FXD:THICK FILM;221 OHM,1%,0.125W,TC=100	50139	BCK221FT
A2R61	321-5010-00			RES,FXD:THICK FILM;221 OHM,1%,0.125W,TC=100	50139	BCK221FT
A2R62	321-5113-00			RES,FXD:THICK FILM;75 OHM,1%,0.125W,TC=100 PPM	56845	CRCW1206-75ROFT
A2R63	321-5008-00			RES,FXD:THICK FILM;150 OHM,1%,0.125W,TC=100	50139	BCK1500FT
A2R64	321-5008-00			RES,FXD:THICK FILM;150 OHM,1%,0.125W,TC=100	50139	BCK1500FT
A2R65	321-5010-00			RES,FXD:THICK FILM;221 OHM,1%,0.125W,TC=100	50139	BCK221FT
A2R66	321-5010-00			RES,FXD:THICK FILM;221 OHM,1%,0.125W,TC=100	50139	BCK221FT
A2R67	321-5113-00			RES,FXD:THICK FILM;75 OHM,1%,0.125W,TC=100 PPM	56845	CRCW1206-75ROFT
A2R68	321-5008-00			RES,FXD:THICK FILM;150 OHM,1%,0.125W,TC=100	50139	BCK1500FT
A2R69	321-5045-00			RES,FXD:THICK FILM;68.1 OHM,1%,0.125W,TC=100 PPM	50139	BCD68R1FT
A2R70	321-5045-00			RES,FXD:THICK FILM;68.1 OHM,1%,0.125W,TC=100 PPM	50139	BCD68R1FT
A2R71	321-5018-00			RES,FXD:THICK FILM;1.0K OHM,1%,0.125W,TC=100 PPM	50139	BCK1001FT
A2R72	321-5018-00			RES,FXD:THICK FILM;1.0K OHM,1%,0.125W,TC=100 PPM	50139	BCK1001FT
A2R73	321-5024-00			RES,FXD:THICK FILM;3.32K OHM,1%,0.125W,TC=100 PPM	50139	BCK3321FT
A2R74	321-5028-00			RES,FXD:THICK FILM;6.81K OHM,1%,0.125W,TC=100 PPM	50139	BCK6811FT
A2R75	321-5028-00			RES,FXD:THICK FILM;6.81K OHM,1%,0.125W,TC=100 PPM	50139	BCK6811FT
A2R76	321-5024-00			RES,FXD:THICK FILM;3.32K OHM,1%,0.125W,TC=100 PPM	50139	BCK3321FT
A2R78	321-5030-00			RES,FXD:THICK FILM;10.0K OHM,1%,0.125W,TC=100 PPM	50139	BCK1002FT
A2R79	321-5055-00			RES,FXD:THICK FILM,681K OHM,1%,0.125W,TC=100 PPM,1206,T&R	59124	RK73H2B6813FT
A2R80	321-5049-00			RES,FXD:THICK FILM;1M OHM,1%,0.125W,TC=100 PPM	57668	MCR18FXEA1M
A2R81	321-5026-00			RES,FXD:THICK FILM;4.75K OHM,1%,0.125W,TC=100 PPM	50139	BCK4751FT
A2R82	321-5024-00			RES,FXD:THICK FILM;3.32K OHM,1%,0.125W,TC=100 PPM	50139	BCK3321FT
A2R83	321-5030-00			RES,FXD:THICK FILM;10.0K OHM,1%,0.125W,TC=100 PPM	50139	BCK1002FT
A2R84	321-5030-00			RES,FXD:THICK FILM;10.0K OHM,1%,0.125W,TC=100 PPM	50139	BCK1002FT
A2R85	321-5019-00			RES,FXD:THICK FILM;1.21K OHM,1%,0.125W,TC=100 PPM	50139	BCK1211FT
A2R86	321-5023-00			RES,FXD:THICK FILM;2.74K OHM,1%,0.125W,TC=100 PPM	50139	BCK2741FT
A2R87	321-5020-00			RES,FXD:THICK FILM;1.5K OHM,1%,0.125W,TC=100 PPM	50139	BCK1501FT
A2R88	321-5043-00			RES,FXD:THICK FILM;47.5 OHM,1%,0.125W,TC=100 PPM	57668	MCR18FWEA47E5
A2R89	321-5043-00			RES,FXD:THICK FILM;47.5 OHM,1%,0.125W,TC=100 PPM	57668	MCR18FWEA47E5
A2R90	321-5036-00			RES,FXD:THICK FILM;33.2K OHM,1%,0.125W,TC=100 PPM	50139	BCK3322FT
A2R91	321-5032-00			RES,FXD:THICK FILM;15.0K OHM,1%,0.125W,TC=100 PPM	50139	BCK1502FT
A2R92	321-5000-00			RES,FXD:THICK FILM;10 OHM,1%,0.125W,TC=100 PPM	59124	RK73H2B10R0FT

Replaceable electrical parts list (Cont.)

Component number	Tektronix part number	Serial no. effective	Serial no. discount'd	Name & description	Mfr. code	Mfr. part number
A2R93	321-5018-00			RES,FXD:THICK FILM;1.0K OHM,1%,0.125W,TC=100 PPM	50139	BCK1001FT
A2R94	308-0677-00			RES,FXD,WW:1 OHM,5%,2W	75042	SPH 1 OHM 5 PER
A2R95	321-5047-00			RES,FXD:THICK FILM;100K OHM,1%,0.125W,TC=100 PPM	50139	BCK1003FT
A2R96	321-5035-00			RES,FXD:THICK FILM;27.4K OHM,1%,0.125W,TC=100 PPM	50139	BCK2742FT
A2R97	321-5026-00			RES,FXD:THICK FILM;4.75K OHM,1%,0.125W,TC=100 PPM	50139	BCK4751FT
A2R98	321-5047-00			RES,FXD:THICK FILM;100K OHM,1%,0.125W,TC=100 PPM	50139	BCK1003FT
A2R99	321-5035-00			RES,FXD:THICK FILM;27.4K OHM,1%,0.125W,TC=100 PPM	50139	BCK2742FT
A2R100	321-5031-00			RES,FXD:THICK FILM;12.1K OHM,1%,0.125W,TC=100 PPM	50139	BCK1212FT
A2R101	321-5030-00			RES,FXD:THICK FILM;10.0K OHM,1%,0.125W,TC=100 PPM	50139	BCK1002FT
A2R102	321-5030-00			RES,FXD:THICK FILM;10.0K OHM,1%,0.125W,TC=100 PPM	50139	BCK1002FT
A2R103	321-5043-00			RES,FXD:THICK FILM;47.5 OHM,1%,0.125W,TC=100 PPM	57668	MCR18FWEA47E5
A2R104	321-5008-00			RES,FXD:THICK FILM;150 OHM,1%,0.125W,TC=100	50139	BCK1500FT
A2R105	321-5046-00			RES,FXD:THICK FILM;82.5 OHM,1%,0.125W,TC=100 PPM	50139	BCK82R5FT
A2R106	321-5007-00			RES,FXD:THICK FILM;121 OHM,1%,0.125W,TC=100	50139	BCK1210FT
A2R107	321-5015-00			RES,FXD:THICK FILM;562 OHM,1%,0.125W,TC=100	50139	BCK5620FT
A2R108	321-5043-00			RES,FXD:THICK FILM;47.5 OHM,1%,0.125W,TC=100 PPM	57668	MCR18FWEA47E5
A2R109	321-5044-00			RES,FXD:THICK FILM;56.2 OHM,1%,0.125W,TC=100 PPM	50139	BCD56R2FT
A2R110	321-5002-00			RES,FXD:THICK FILM;15 OHM,1%,0.125W,TC=100 PPM	59124	RK73H2B15R0FT
A2R111	321-5000-00			RES,FXD:THICK FILM;10 OHM,1%,0.125W,TC=100 PPM	59124	RK73H2B10R0FT
A2R112	321-5006-00			RES,FXD:THICK FILM;100 OHM,1%,0.125W,TC=100	50139	BCK1000FT
A2R113	321-5030-00			RES,FXD:THICK FILM;10.0K OHM,1%,0.125W,TC=100 PPM	50139	BCK1002FT
A2R114	321-5014-00			RES,FXD:THICK FILM;475 OHM,1%,0.125W,TC=100	50139	BCK4750FT
A2R115	321-5014-00			RES,FXD:THICK FILM;475 OHM,1%,0.125W,TC=100	50139	BCK4750FT
A2R116	321-5014-00			RES,FXD:THICK FILM;475 OHM,1%,0.125W,TC=100	50139	BCK4750FT
A2R117	321-5014-00			RES,FXD:THICK FILM;475 OHM,1%,0.125W,TC=100	50139	BCK4750FT
A2R118	321-5022-00			RES,FXD:THICK FILM;2.21K OHM,1%,0.125W,TC=100 PPM	50139	BCK2211FT
A2R119	321-5022-00			RES,FXD:THICK FILM;2.21K OHM,1%,0.125W,TC=100 PPM	50139	BCK2211FT
A2R120	321-5034-00			RES,FXD:THICK FILM;22.1K OHM,1%,0.125W,TC=100 PPM	50139	BCK2212FT
A2R121	321-5018-00			RES,FXD:THICK FILM;1.0K OHM,1%,0.125W,TC=100 PPM	50139	BCK1001FT
A2R122	321-5018-00			RES,FXD:THICK FILM;1.0K OHM,1%,0.125W,TC=100 PPM	50139	BCK1001FT
A2R128	321-5045-00			RES,FXD:THICK FILM;68.1 OHM,1%,0.125W,TC=100 PPM	50139	BCD68R1FT
A2R129	321-5045-00			RES,FXD:THICK FILM;68.1 OHM,1%,0.125W,TC=100 PPM	50139	BCD68R1FT
A2R130	321-5045-00			RES,FXD:THICK FILM;68.1 OHM,1%,0.125W,TC=100 PPM	50139	BCD68R1FT
A2R131	321-5026-00			RES,FXD:THICK FILM;4.75K OHM,1%,0.125W,TC=100 PPM	50139	BCK4751FT
A2R132	321-5026-00			RES,FXD:THICK FILM;4.75K OHM,1%,0.125W,TC=100 PPM	50139	BCK4751FT
A2R133	321-5014-00			RES,FXD:THICK FILM;475 OHM,1%,0.125W,TC=100	50139	BCK4750FT
A2R157	321-5018-00			RES,FXD:THICK FILM;1.0K OHM,1%,0.125W,TC=100 PPM	50139	BCK1001FT
A2R158	321-5024-00			RES,FXD:THICK FILM;3.32K OHM,1%,0.125W,TC=100 PPM	50139	BCK3321FT

Replaceable electrical parts list (Cont.)

Component number	Tektronix part number	Serial no. effective	Serial no. discontin'd	Name & description	Mfr. code	Mfr. part number
A2R159	321-5004-00			RES,FXD:THICK FILM;22.1 OHM,1%,0.125W,TC=100 PPM	57668	MCR18FWEA22E1
A2R160	321-5004-00			RES,FXD:THICK FILM;22.1 OHM,1%,0.125W,TC=100 PPM	57668	MCR18FWEA22E1
A2R161	321-5030-00			RES,FXD:THICK FILM;10.0K OHM,1%,0.125W,TC=100 PPM	50139	BCK1002FT
A2R162	321-5030-00			RES,FXD:THICK FILM;10.0K OHM,1%,0.125W,TC=100 PPM	50139	BCK1002FT
A2R163	321-5028-00			RES,FXD:THICK FILM;6.81K OHM,1%,0.125W,TC=100 PPM	50139	BCK6811FT
A2R164	321-5008-00			RES,FXD:THICK FILM;150 OHM,1%,0.125W,TC=100	50139	BCK1500FT
A2R165	321-5048-00			RES,FXD:THICK FILM;332K OHM,1%,0.125W,TC=100 PPM	57668	MCR18FXEA332K
A2R166	321-5018-00			RES,FXD:THICK FILM;1.0K OHM,1%,0.125W,TC=100 PPM	50139	BCK1001FT
A2R167	321-5030-00			RES,FXD:THICK FILM;10.0K OHM,1%,0.125W,TC=100 PPM	50139	BCK1002FT
A2R168	321-5018-00			RES,FXD:THICK FILM;1.0K OHM,1%,0.125W,TC=100 PPM	50139	BCK1001FT
A2R169	321-5021-00			RES,FXD:THICK FILM;1.82K OHM,1%,0.125W,TC=100 PPM	50139	BCK1821FT
A2R170	321-5020-00			RES,FXD:THICK FILM;1.5K OHM,1%,0.125W,TC=100 PPM	50139	BCK1501FT
A2R171	321-5024-00			RES,FXD:THICK FILM;3.32K OHM,1%,0.125W,TC=100 PPM	50139	BCK3321FT
A2R172	321-5010-00			RES,FXD:THICK FILM;221 OHM,1%,0.125W,TC=100	50139	BCK221FT
A2R174	321-5026-00			RES,FXD:THICK FILM;4.75K OHM,1%,0.125W,TC=100 PPM	50139	BCK4751FT
A2R175	321-5026-00			RES,FXD:THICK FILM;4.75K OHM,1%,0.125W,TC=100 PPM	50139	BCK4751FT
A2R176	321-5026-00			RES,FXD:THICK FILM;4.75K OHM,1%,0.125W,TC=100 PPM	50139	BCK4751FT
A2R177	321-5026-00			RES,FXD:THICK FILM;4.75K OHM,1%,0.125W,TC=100 PPM	50139	BCK4751FT
A2R178	321-5034-00			RES,FXD:THICK FILM;22.1K OHM,1%,0.125W,TC=100 PPM	50139	BCK2212FT
A2R179	321-5034-00			RES,FXD:THICK FILM;22.1K OHM,1%,0.125W,TC=100 PPM	50139	BCK2212FT
A2R180	321-5031-00			RES,FXD:THICK FILM;12.1K OHM,1%,0.125W,TC=100 PPM	50139	BCK1212FT
A2R181	321-5034-00			RES,FXD:THICK FILM;22.1K OHM,1%,0.125W,TC=100 PPM	50139	BCK2212FT
A2R182	321-5024-00			RES,FXD:THICK FILM;3.32K OHM,1%,0.125W,TC=100 PPM	50139	BCK3321FT
A2R183	321-5026-00			RES,FXD:THICK FILM;4.75K OHM,1%,0.125W,TC=100 PPM	50139	BCK4751FT
A2R184	321-5026-00			RES,FXD:THICK FILM;4.75K OHM,1%,0.125W,TC=100 PPM	50139	BCK4751FT
A2R185	321-5000-00			RES,FXD:THICK FILM;10 OHM,1%,0.125W,TC=100 PPM	59124	RK73H2B10R0FT
A2R186	321-5004-00			RES,FXD:THICK FILM;22.1 OHM,1%,0.125W,TC=100 PPM	57668	MCR18FWEA22E1
A2R187	321-5030-00			RES,FXD:THICK FILM;10.0K OHM,1%,0.125W,TC=100 PPM	50139	BCK1002FT
A2R188	321-5036-00			RES,FXD:THICK FILM;33.2K OHM,1%,0.125W,TC=100 PPM	50139	BCK3322FT
A2R189	321-5018-00			RES,FXD:THICK FILM,1.0K OHM,1%,0.125W,TC=100 PPM,1206,T&R	50139	BCK1001FT
A2R190	321-5032-00			RES,FXD:THICK FILM;15.0K OHM,1%,0.125W,TC=100 PPM	50139	BCK1502FT
A2R191	321-5026-00			RES,FXD:THICK FILM;4.75K OHM,1%,0.125W,TC=100 PPM	50139	BCK4751FT
A2R192	321-5045-00			RES,FXD:THICK FILM;68.1 OHM,1%,0.125W,TC=100 PPM	50139	BCD68R1FT
A2R193	321-5018-00			RES,FXD:THICK FILM;1.0K OHM,1%,0.125W,TC=100 PPM	50139	BCK1001FT
A2R195	321-5018-00			RES,FXD:THICK FILM;1.0K OHM,1%,0.125W,TC=100 PPM	50139	BCK1001FT
A2R197	321-5018-00			RES,FXD:THICK FILM;1.0K OHM,1%,0.125W,TC=100 PPM	50139	BCK1001FT
A2R198	321-5018-00			RES,FXD:THICK FILM;1.0K OHM,1%,0.125W,TC=100 PPM	50139	BCK1001FT
A2R199	321-5018-00			RES,FXD:THICK FILM;1.0K OHM,1%,0.125W,TC=100 PPM	50139	BCK1001FT

Replaceable electrical parts list (Cont.)

Component number	Tektronix part number	Serial no. effective	Serial no. discont'd	Name & description	Mfr. code	Mfr. part number
A2R200	321-5043-00			RES,FXD:THICK FILM;47.5 OHM,1%,0.125W,TC=100 PPM	57668	MCR18FWEA47E5
A2R201	321-5030-00			RES,FXD:THICK FILM;10.0K OHM,1%,0.125W,TC=100 PPM	50139	BCK1002FT
A2R300	321-5030-00		671-3124-05	RES,FXD:THICK FILM,10.0K OHM,1%,0.125W,TC=100 PPM	50139	BCK1002FT
A2R300	321-5018-00	671-3124-06		RES,FXD:THICK FILM,1.0K OHM,1%,0.125W,TC=100 PPM	50139	BCK1001FT
A2R301	321-5045-00			RES,FXD:THICK FILM,68.1 OHM,1%,0.125W,TC=100 PPM	50139	BCD68R1FT
A2R302	321-5045-00			RES,FXD:THICK FILM,68.1 OHM,1%,0.125W,TC=100 PPM	50139	BCD68R1FT
A2R500	321-5008-00			RES,FXD:THICK FILM;150 OHM,1%,0.125W,TC=100	50139	BCK1500FT
A2R501	321-5008-00			RES,FXD:THICK FILM;150 OHM,1%,0.125W,TC=100	50139	BCK1500FT
A2R502	321-5008-00			RES,FXD:THICK FILM;150 OHM,1%,0.125W,TC=100	50139	BCK1500FT
A2R503	321-5004-00			RES,FXD:THICK FILM;22.1 OHM,1%,0.125W,TC=100 PPM	57668	MCR18FWEA22E1
A2R504	321-5004-00			RES,FXD:THICK FILM;22.1 OHM,1%,0.125W,TC=100 PPM	57668	MCR18FWEA22E1
A2R505	321-5004-00			RES,FXD:THICK FILM;22.1 OHM,1%,0.125W,TC=100 PPM	57668	MCR18FWEA22E1
A2R506	321-5004-00			RES,FXD:THICK FILM;22.1 OHM,1%,0.125W,TC=100 PPM	57668	MCR18FWEA22E1
A2R507	321-5004-00			RES,FXD:THICK FILM;22.1 OHM,1%,0.125W,TC=100 PPM	57668	MCR18FWEA22E1
A2R507	321-5050-00			RES,FXD:THICK FILM;33.2 OHM,1%,0.125W,TC=100 PPM	57668	MCR18FWEA33E2
A2R508	321-5004-00			RES,FXD:THICK FILM;22.1 OHM,1%,0.125W,TC=100 PPM	57668	MCR18FWEA22E1
A2R509	321-5004-00			RES,FXD:THICK FILM;22.1 OHM,1%,0.125W,TC=100 PPM	57668	MCR18FWEA22E1
A2R510	321-5005-00			RES,FXD:THICK FILM;27.4 OHM,1%,0.125W,TC=100 PPM	57668	MCR18EZHFW 27E4
A2R511	321-5005-00			RES,FXD:THICK FILM;27.4 OHM,1%,0.125W,TC=100 PPM	57668	MCR18EZHFW 27E4
A2R512	321-5000-00			RES,FXD:THICK FILM;10 OHM,1%,0.125W,TC=100 PPM	59124	RK73H2B10R0FT
A2R513	321-5002-00			RES,FXD:THICK FILM;15 OHM,1%,0.125W,TC=100 PPM	59124	RK73H2B15R0FT
A2R551	321-5050-00			RES,FXD:THICK FILM;33.2 OHM,1%,0.125W,TC=100 PPM	57668	MCR18FWEA33E2
A2R552	321-5050-00			RES,FXD:THICK FILM;33.2 OHM,1%,0.125W,TC=100 PPM	57668	MCR18FWEA33E2
A2R1000	321-5012-00			RES,FXD:THICK FILM;332 OHM,1%,0.125W,TC=100	50139	BCK3320FT
A2R1001	321-5014-00			RES,FXD:THICK FILM;475 OHM,1%,0.125W,TC=100	50139	BCK4750FT
A2R1002	321-5012-00			RES,FXD:THICK FILM;332 OHM,1%,0.125W,TC=100	50139	BCK3320FT
A2R1003	321-5014-00			RES,FXD:THICK FILM;475 OHM,1%,0.125W,TC=100	50139	BCK4750FT
A2R1004	321-5012-00			RES,FXD:THICK FILM;332 OHM,1%,0.125W,TC=100	50139	BCK3320FT
A2R1005	321-5012-00			RES,FXD:THICK FILM;332 OHM,1%,0.125W,TC=100	50139	BCK3320FT
A2R1006	321-5012-00			RES,FXD:THICK FILM;332 OHM,1%,0.125W,TC=100	50139	BCK3320FT
A2R1007	321-5012-00			RES,FXD:THICK FILM;332 OHM,1%,0.125W,TC=100	50139	BCK3320FT
A2R1008	321-5012-00			RES,FXD:THICK FILM;332 OHM,1%,0.125W,TC=100	50139	BCK3320FT
A2R1009	321-5012-00			RES,FXD:THICK FILM;332 OHM,1%,0.125W,TC=100	50139	BCK3320FT
A2R1010	321-5012-00			RES,FXD:THICK FILM;332 OHM,1%,0.125W,TC=100	50139	BCK3320FT
A2R1011	321-5012-00			RES,FXD:THICK FILM;332 OHM,1%,0.125W,TC=100	50139	BCK3320FT
A2R1012	321-5012-00			RES,FXD:THICK FILM;332 OHM,1%,0.125W,TC=100	50139	BCK3320FT
A2R1013	321-5012-00			RES,FXD:THICK FILM;332 OHM,1%,0.125W,TC=100	50139	BCK3320FT
A2R1014	321-5012-00			RES,FXD:THICK FILM;332 OHM,1%,0.125W,TC=100	50139	BCK3320FT

Replaceable electrical parts list (Cont.)

Component number	Tektronix part number	Serial no. effective	Serial no. discont'd	Name & description	Mfr. code	Mfr. part number
A2R1015	321-5012-00			RES,FXD:THICK FILM;332 OHM,1%,0.125W,TC=100	50139	BCK3320FT
A2R1016	321-5012-00			RES,FXD:THICK FILM;332 OHM,1%,0.125W,TC=100	50139	BCK3320FT
A2R1017	321-5012-00			RES,FXD:THICK FILM;332 OHM,1%,0.125W,TC=100	50139	BCK3320FT
A2R1018	321-5012-00			RES,FXD:THICK FILM;332 OHM,1%,0.125W,TC=100	50139	BCK3320FT
A2R1019	321-5012-00			RES,FXD:THICK FILM;332 OHM,1%,0.125W,TC=100	50139	BCK3320FT
A2R1020	321-5012-00			RES,FXD:THICK FILM;332 OHM,1%,0.125W,TC=100	50139	BCK3320FT
A2R1021	321-5012-00			RES,FXD:THICK FILM;332 OHM,1%,0.125W,TC=100	50139	BCK3320FT
A2R1022	321-5012-00			RES,FXD:THICK FILM;332 OHM,1%,0.125W,TC=100	50139	BCK3320FT
A2R1023	321-5051-00			RES,FXD:THICK FILM;0 OHM,1%,0.125W,TC=100 PPM	09969	CRCW1206 JUMPER
A2R1024	321-5030-00			RES,FXD:THICK FILM;10.0K OHM,1%,0.125W,TC=100 PPM	50139	BCK1002FT
A2R1025	321-5051-00			RES,FXD:THICK FILM;0 OHM,1%,0.125W,TC=100 PPM	09969	CRCW1206 JUMPER
A2R1026	321-5030-00			RES,FXD:THICK FILM;10.0K OHM,1%,0.125W,TC=100 PPM	50139	BCK1002FT
A2R1027	321-5030-00			RES,FXD:THICK FILM;10.0K OHM,1%,0.125W,TC=100 PPM	50139	BCK1002FT
A2R1028	321-5030-00			RES,FXD:THICK FILM;10.0K OHM,1%,0.125W,TC=100 PPM	50139	BCK1002FT
A2R1029	321-5030-00			RES,FXD:THICK FILM;10.0K OHM,1%,0.125W,TC=100 PPM	50139	BCK1002FT
A2R1030	321-5030-00			RES,FXD:THICK FILM;10.0K OHM,1%,0.125W,TC=100 PPM	50139	BCK1002FT
A2R1031	321-5018-00			RES,FXD:THICK FILM;1.0K OHM,1%,0.125W,TC=100 PPM	50139	BCK1001FT
A2R1032	321-5014-00			RES,FXD:THICK FILM;475 OHM,1%,0.125W,TC=100	50139	BCK4750FT
A2R1033	321-5027-00			RES,FXD:THICK FILM;5.62K OHM,1%,0.125W,TC=100 PPM	50139	BCK5621FT
A2R1034	321-5019-00			RES,FXD:THICK FILM;1.21K OHM,1%,0.125W,TC=100 PPM	50139	BCK1211FT
A2R1035	321-5030-00			RES,FXD:THICK FILM;10.0K OHM,1%,0.125W,TC=100 PPM	50139	BCK1002FT
A2R1037	321-5030-00			RES,FXD:THICK FILM;10.0K OHM,1%,0.125W,TC=100 PPM	50139	BCK1002FT
A2R1039	321-5045-00			RES,FXD:THICK FILM;68.1 OHM,1%,0.125W,TC=100 PPM	50139	BCD68R1FT
A2R1040	321-5045-00			RES,FXD:THICK FILM;68.1 OHM,1%,0.125W,TC=100 PPM	50139	BCD68R1FT
A2R1041	321-5014-00			RES,FXD:THICK FILM;475 OHM,1%,0.125W,TC=100	50139	BCK4750FT
A2R1042	321-5005-00			RES,FXD:THICK FILM;27.4 OHM,1%,0.125W,TC=100 PPM	57668	MCR18EZHFW 27E4
A2R1043	321-5046-00			RES,FXD:THICK FILM;82.5 OHM,1%,0.125W,TC=100 PPM	50139	BCK82R5FT
A2R1044	321-5017-00			RES,FXD:THICK FILM;825 OHM,1%,0.125W,TC=100	50139	BCK8250FT
A2R1045	321-5017-00			RES,FXD:THICK FILM;825 OHM,1%,0.125W,TC=100	50139	BCK8250FT
A2R1046	321-5017-00			RES,FXD:THICK FILM;825 OHM,1%,0.125W,TC=100	50139	BCK8250FT
A2R1047	321-5005-00			RES,FXD:THICK FILM;27.4 OHM,1%,0.125W,TC=100 PPM	57668	MCR18EZHFW 27E4
A2R1048	321-5045-00			RES,FXD:THICK FILM;68.1 OHM,1%,0.125W,TC=100 PPM	50139	BCD68R1FT
A2R1049	321-5045-00			RES,FXD:THICK FILM;68.1 OHM,1%,0.125W,TC=100 PPM	50139	BCD68R1FT
A2R1050	321-5014-00			RES,FXD:THICK FILM;475 OHM,1%,0.125W,TC=100	50139	BCK4750FT
A2R1051	321-5005-00			RES,FXD:THICK FILM;27.4 OHM,1%,0.125W,TC=100 PPM	57668	MCR18EZHFW 27E4
A2R1052	321-5046-00			RES,FXD:THICK FILM;82.5 OHM,1%,0.125W,TC=100 PPM	50139	BCK82R5FT
A2R1053	321-5017-00			RES,FXD:THICK FILM;825 OHM,1%,0.125W,TC=100	50139	BCK8250FT
A2R1054	321-5017-00			RES,FXD:THICK FILM;825 OHM,1%,0.125W,TC=100	50139	BCK8250FT

Replaceable electrical parts list (Cont.)

Component number	Tektronix part number	Serial no. effective	Serial no. discont'd	Name & description	Mfr. code	Mfr. part number
A2R1055	321-5017-00			RES,FXD:THICK FILM;825 OHM,1%,0.125W,TC=100	50139	BCK8250FT
A2R1056	321-5005-00			RES,FXD:THICK FILM;27.4 OHM,1%,0.125W,TC=100 PPM	57668	MCR18EZHF27E4
A2R1057	321-5045-00			RES,FXD:THICK FILM;68.1 OHM,1%,0.125W,TC=100 PPM	50139	BCD68R1FT
A2R1058	321-5045-00			RES,FXD:THICK FILM;68.1 OHM,1%,0.125W,TC=100 PPM	50139	BCD68R1FT
A2R1059	321-5014-00			RES,FXD:THICK FILM;475 OHM,1%,0.125W,TC=100	50139	BCK4750FT
A2R1060	321-5005-00			RES,FXD:THICK FILM;27.4 OHM,1%,0.125W,TC=100 PPM	57668	MCR18EZHF27E4
A2R1061	321-5046-00			RES,FXD:THICK FILM;82.5 OHM,1%,0.125W,TC=100 PPM	50139	BCK82R5FT
A2R1062	321-5017-00			RES,FXD:THICK FILM;825 OHM,1%,0.125W,TC=100	50139	BCK8250FT
A2R1063	321-5017-00			RES,FXD:THICK FILM;825 OHM,1%,0.125W,TC=100	50139	BCK8250FT
A2R1064	321-5017-00			RES,FXD:THICK FILM;825 OHM,1%,0.125W,TC=100	50139	BCK8250FT
A2R1065	321-5005-00			RES,FXD:THICK FILM;27.4 OHM,1%,0.125W,TC=100 PPM	57668	MCR18EZHF27E4
A2R1066	321-5010-00			RES,FXD:THICK FILM;221 OHM,1%,0.125W,TC=100	50139	BCK221FT
A2R1067	321-5010-00			RES,FXD:THICK FILM;221 OHM,1%,0.125W,TC=100	50139	BCK221FT
A2R1068	321-5014-00			RES,FXD:THICK FILM;475 OHM,1%,0.125W,TC=100	50139	BCK4750FT
A2R1069	321-5027-00			RES,FXD:THICK FILM;5.62K OHM,1%,0.125W,TC=100 PPM	50139	BCK5621FT
A2R1070	321-5027-00			RES,FXD:THICK FILM;5.62K OHM,1%,0.125W,TC=100 PPM	50139	BCK5621FT
A2R1071	321-5032-00			RES,FXD:THICK FILM;15.0K OHM,1%,0.125W,TC=100 PPM	50139	BCK1502FT
A2R1072	321-5032-00			RES,FXD:THICK FILM;15.0K OHM,1%,0.125W,TC=100 PPM	50139	BCK1502FT
A2R1073	321-5012-00			RES,FXD:THICK FILM;332 OHM,1%,0.125W,TC=100	50139	BCK3320FT
A2R1074	321-5044-00			RES,FXD:THICK FILM;56.2 OHM,1%,0.125W,TC=100 PPM	50139	BCD56R2FT
A2R1075	321-5266-00			RES,FXD:THICK FILM;11K OHM,1%,0.125W,TC=100	59124	RK73H2B1102FT
A2R1078	321-5051-00			RES,FXD:THICK FILM;0 OHM,1%,0.125W,TC=100 PPM	09969	CRCW1206 JUMPER
A2R1080	321-5051-00			RES,FXD:THICK FILM;0 OHM,1%,0.125W,TC=100 PPM	09969	CRCW1206 JUMPER
A2R1081	321-5051-00			RES,FXD:THICK FILM;0 OHM,1%,0.125W,TC=100 PPM	09969	CRCW1206 JUMPER
A2R1082	321-5014-00			RES,FXD:THICK FILM;475 OHM,1%,0.125W,TC=100	50139	BCK4750FT
A2R1083	322-3289-00	671-3124-04	671-3124-04	RES;METAL FILM;10.0K OHM,1%,0.2W,TC=100 PPM	57668	CRB20T29EFX1002
A2R1083	321-5030-00	671-3124-05		RES;METAL FILM;10.0K OHM,1%,0.2W,TC=100 PPM	50139	BCK1002FT
A2S1	260-1721-00			SWITCH,ROCKER:8,SPST,125MA,30VDC	81073	76SB08S
A2TP1	214-4085-00			TERM,TEST POINT:0.070 ID,0.220 H,0.063 DIAP CB,0.015 X 0.032 BRASS,W/RED NYLON COLLAR	26364	104-01-02
A2TP2	214-4085-00			TERM,TEST POINT:0.070 ID,0.220 H,0.063 DIAP CB,0.015 X 0.032 BRASS,W/RED NYLON COLLAR	26364	104-01-02
A2TP3	214-4085-00			TERM,TEST POINT:0.070 ID,0.220 H,0.063 DIAP CB,0.015 X 0.032 BRASS,W/RED NYLON COLLAR	26364	104-01-02
A2TP4	214-4085-00			TERM,TEST POINT:0.070 ID,0.220 H,0.063 DIAP CB,0.015 X 0.032 BRASS,W/RED NYLON COLLAR	26364	104-01-02
A2TP5	214-4085-00			TERM,TEST POINT:0.070 ID,0.220 H,0.063 DIAP CB,0.015 X 0.032 BRASS,W/RED NYLON COLLAR	26364	104-01-02
A2TP6	214-4085-00			TERM,TEST POINT:0.070 ID,0.220 H,0.063 DIAP CB,0.015 X 0.032 BRASS,W/RED NYLON COLLAR	26364	104-01-02

Replaceable electrical parts list (Cont.)

Component number	Tektronix part number	Serial no. effective	Serial no. discont'd	Name & description	Mfr. code	Mfr. part number
A2TP7	214-4085-00			TERM,TEST POINT:0.070 ID,0.220 H,0.063 DIAP CB,0.015 X 0.032 BRASS,W/RED NYLON COLLAR	26364	104-01-02
A2TP8	214-4085-00			TERM,TEST POINT:0.070 ID,0.220 H,0.063 DIAP CB,0.015 X 0.032 BRASS,W/RED NYLON COLLAR	26364	104-01-02
A2TP9	214-4085-00			TERM,TEST POINT:0.070 ID,0.220 H,0.063 DIAP CB,0.015 X 0.032 BRASS,W/RED NYLON COLLAR	26364	104-01-02
A2TP10	214-4085-00			TERM,TEST POINT:0.070 ID,0.220 H,0.063 DIAP CB,0.015 X 0.032 BRASS,W/RED NYLON COLLAR	26364	104-01-02
A2TP11	214-4085-00			TERM,TEST POINT:0.070 ID,0.220 H,0.063 DIAP CB,0.015 X 0.032 BRASS,W/RED NYLON COLLAR	26364	104-01-02
A2TP12	214-4085-00			TERM,TEST POINT:0.070 ID,0.220 H,0.063 DIAP CB,0.015 X 0.032 BRASS,W/RED NYLON COLLAR	26364	104-01-02
A2TP13	214-4085-00			TERM,TEST POINT:0.070 ID,0.220 H,0.063 DIAP CB,0.015 X 0.032 BRASS,W/RED NYLON COLLAR	26364	104-01-02
A2TP16	214-4085-00			TERM,TEST POINT:0.070 ID,0.220 H,0.063 DIAP CB,0.015 X 0.032 BRASS,W/RED NYLON COLLAR	26364	104-01-02
A2TP17	214-4085-00			TERM,TEST POINT:0.070 ID,0.220 H,0.063 DIAP CB,0.015 X 0.032 BRASS,W/RED NYLON COLLAR	26364	104-01-02
A2TP18	214-4085-00			TERM,TEST POINT:0.070 ID,0.220 H,0.063 DIAP CB,0.015 X 0.032 BRASS,W/RED NYLON COLLAR	26364	104-01-02
A2TP19	214-4085-00			TERM,TEST POINT:0.070 ID,0.220 H,0.063 DIAP CB,0.015 X 0.032 BRASS,W/RED NYLON COLLAR	26364	104-01-02
A2U1	156-6665-00			IC,MISC:CMOS,PWR SPLY SUPERVISOR;MPU RESET GENERATOR,5V SPLY SENSING,MPU WATCHDOGTIMER	1ES66	MAX1232CSA (C74
A2U2	156-5098-01			IC,DIGITAL:HCTCMOS,GATE:QUAD 2-INPUT NAND	01295	SN74HCT00DR
A2U3	156-6870-00			IC,PROCESSOR:CMOS,MICROCOMPUTER;16 BIT,8MHZ	4T165	UPD70320L-8
A2U4	156-6274-01			IC,MEMORY:CMOS,SRAM;32K X 8,25NS	80009	156627401
A2U5	156-2671-00			IC,MEMORY:CMOS,NVRAM;2K X 8,200NS,SRAM,INTEGRAL BATTERY	0B0A9	DS1220Y
A2U6	156-5071-01			IC,DIGITAL:HCTCMOS,TRANSCEIVER:OCTAL,3-STATE	0JR04	TC74HCT245AFW(E
A2U7	156-5070-01			IC,DIGITAL:HCTCMOS,BFR:OCTAL BFR/DRIVER, 3-STATE	0JR04	TC74HCT244AFW(E
A2U8	156-5070-01			IC,DIGITAL:HCTCMOS,BFR:OCTAL BFR/DRIVER, 3-STATE	0JR04	TC74HCT244AFW(E
A2U9	163-0298-00			IC,DGTL:CMOS,PLD,EEPLD,7128E,128 M/C,64 I/O,4 IN,15NS	TK0198	163029800
	136-5010-00		671-3124-01	SOCKET,PLCC:SMD;84 POS,0.05 CTR,0.186H,TIN,W/PLZ POST	22526	69802-084
A2U10	160-9921-01	671-3124-01	671-3124-02	IC,MEMORY:CMOS,EPROM,256K X 8,150NS,PRGM	80009	160-9921-01
A2U10	160-9921-02	671-3124-03	671-3124-06	IC,MEMORY:CMOS,EPROM,256K X 8,150NS,PRGM	TK0198	160-9921-02
A2U10	160-9921-03	671-3124-07	671-3124-08	IC,MEMORY:CMOS,EPROM,256K X 8,150NS,PRGM	TK0198	160-9921-08
A2U10	160-9921-06	671-3124-08		IC,MEMORY:CMOS,EPROM,256K X 8,150NS,PRGM	TK0198	160-9921-08
A2U11	160-9922-01	671-3124-01	671-3124-02	IC,MEMORY:CMOS,EPROM,256K X 8,150NS,PRGM	80009	160-9922-01
A2U11	160-9922-02	671-3124-03	671-3124-06	IC,MEMORY:CMOS,EPROM,256K X 8,150NS,PRGM	TK0198	160-9922-02
A2U11	160-9922-05	671-3124-08		IC,MEMORY:CMOS,EPROM,256K X 8,150NS,PRGM	TK0198	160-9922-05
	136-1223-00			SOCKET,PLCC:PCB;32 POS,0.05 CTR,0.86 X 0.740 WIDE	00779	821665-1
A2U12	156-0878-00			IC,MISC:TTL,INTERFACE:QUAD RS-232 LINE RECEIVER	01295	SN75189N

Replaceable electrical parts list (Cont.)

Component number	Tektronix part number	Serial no. effective	Serial no. discont'd	Name & description	Mfr. code	Mfr. part number
	136-0728-00			SKT,PL-IN ELEK:PCB;14 POS,2 X 7,0.1 X 0.3CTR,0.210 H X 0.140 TAIL,TIN	00779	2-641599-3
A2U13	156-0879-00			IC,MISC:TTL,INTERFACE;QUAD RS-232 LINE DRIVER	01295	SN75188N
	136-0728-00			SKT,PL-IN ELEK:PCB;14 POS,2 X 7,0.1 X 0.3CTR,0.210 H X 0.140 TAIL,TIN	00779	2-641599-3
A2U14	156-5296-00			IC,DIGITAL:ALSTTL,FLIP FLOP;OCTAL NONINV D-TYPE, 3-STATE	01295	SN74ALS374ADW
A2U15	156-5296-00			IC,DIGITAL:ALSTTL,FLIP FLOP;OCTAL NONINV D-TYPE, 3-STATE	01295	SN74ALS374ADW
A2U16	156-5296-00			IC,DIGITAL:ALSTTL,FLIP FLOP;OCTAL NONINV D-TYPE, 3-STATE	01295	SN74ALS374ADW
A2U17	156-6464-00			IC,DIGITAL:HCTCMOS,XCVR;OCTAL RGTRD,3-STATE	01295	SN74HCT652DW
A2U19	156-5070-01			IC,DIGITAL:HCTCMOS,BFR;OCTBFRAL /DRIVER, 3-STATE	0JR04	TC74HCT244AFW(E
A2U20	156-1215-00			IC,DIGITAL:CMOS,MUX/ENCODER;20-KEY ENCODER	27014	MM74C923N
A2U21	156-5070-01			IC,DIGITAL:HCTCMOS,BFR;OCTAL BFR/DRIVER, 3-STATE	0JR04	TC74HCT244AFW(E
A2U22	156-5043-01			IC,CONVERTER:BIPOLAR,D/A;8 BIT,CURRENT OUT, MULTIPLYING	1CH66	DAC08EDT
A2U23	156-5017-01			IC,LINEAR:BIPOLAR,OP-AMP;DUAL	01295	MC1458DR
A2U24	156-6143-01			MICROCKT,DGTL:DUAL 4 CHANNEL,ANALOG MULTIPLEXER/ DEMULTIPLEXER	80009	156614301
A2U25	160-0293-00			MICROCKT,DGTL:2048 X 8 EPROM,PROGRAMMED2716	80009	160-0293-00
	136-5010-00			SOCKET,PLCC:SMD;84 POS,0.05 CTR,0.186H,TIN,W/PLZ POST,TUBE PACK	22526	69802-084
A2U26	156-6274-01			IC,MEMORY:CMOS,SRAM;32K X 8,25NS	80009	156627401
A2U27	156-6274-01			IC,MEMORY:CMOS,SRAM;32K X 8,25NS	80009	156627401
A2U30	156-5070-01			IC,DIGITAL:HCTCMOS,BFR;OCTAL BFR/DRIVER, 3-STATE	0JR04	TC74HCT244AFW(E
A2U31	156-5070-01			IC,DIGITAL:HCTCMOS,BFR;OCTAL BFR/DRIVER, 3-STATE	0JR04	TC74HCT244AFW(E
A2U32	156-5071-01			IC,DIGITAL:HCTCMOS,TRANSCEIVER;OCTAL,3-STATE	0JR04	TC74HCT245AFW(E
A2U33	156-5071-01			IC,DIGITAL:HCTCMOS,TRANSCEIVER;OCTAL,3-STATE	0JR04	TC74HCT245AFW(E
A2U34	163-0294-01			IC,DIGITAL:CMOS,PLD,EEPLD,7128E,128 M/C,64 I/O,4 IN,15 NS,PRGM 156-6780-00,EPM7128E-15,PLCC	TK0198	163029401
	136-5010-00			SOCKET,PLCC:SMD;84 POS,0.05 CTR,0.186H,TIN,W/PLZ POST,TUBE PACK	22526	69802-084
A2U35	156-6143-01			MICROCKT,DGTL:DUAL 4 CHANNEL,ANALOG MULTIPLEXER/ DEMULTIPLEXER	80009	156614301
A2U36	156-6547-00		671-3124-06	IC,MEMORY:CMOS,EPROM;64K X 8,150NS	34335	AM27C512-150JC
A2U36	163-0299-01	671-3124-07	671-3124-08	IC,MEMORY:CMOS,EPROM,64K X 8,150NS,PRGM	TK0198	163029901
	136-5011-00			SOCKET,PLCC:SMD;32 POS,0.05 CTR,0.800X 0.700 INCH WIDE,0.200 H,BE/CU,TIN,W/O PLZ POSTS	22526	69802-132
A2U37	156-5070-01			IC,DIGITAL:HCTCMOS,BFR;OCTAL BFR/DRIVER, 3-STATE	0JR04	TC74HCT244AFW(E
A2U38	156-5070-01			IC,DIGITAL:HCTCMOS,BFR;OCTAL BFR/DRIVER, 3-STATE	0JR04	TC74HCT244AFW(E
A2U39	156-5071-01			IC,DIGITAL:HCTCMOS,TRANSCEIVER;OCTAL,3-STATE	0JR04	TC74HCT245AFW(E

Replaceable electrical parts list (Cont.)

Component number	Tektronix part number	Serial no. effective	Serial no. discont'd	Name & description	Mfr. code	Mfr. part number
A2U40	156-5071-01			IC,DIGITAL:HCTCMOS,TRANSCEIVER,OCTAL,3-STATE	0JR04	TC74HCT245AFW(E)
A2U41	156-5164-01			IC,DIGITAL:FTTL,GATES:QUAD 2-INPUT NAND,OC	01295	SN74F38DR
A2U42	156-6794-00			IC,MEMORY:CMOS,SRAM;32K X 8,15NS,5C2568,SOJ28.300	TK2519	AS7C256-15JC
A2U43	156-6794-00			IC,MEMORY:CMOS,SRAM;32K X 8,15NS,5C2568,SOJ28.300	TK2519	AS7C256-15JC
A2U44	156-6718-00			IC,DIGITAL:CMOS,PLD:FPGA,XC3100A FAMILY,3195,484 CLBS,176 IOBS,70 I/O,230 MHZ	68994	XC3195A-4PC84C
A2U45	156-6674-00			IC,DIGITAL:CMOS,PLD:FPGA,XC3100A FAMILY,3190,320 CLBS,144 IOBS,70 I/O,230 MHZ	68994	XC3190A-4PC84C
A2U46	156-6668-00			IC,MISC:ECL,MISC:GENLINX CABLE DRIVER WITHTWO ADJUSTABLE OUTPUTS	37964	GS9008
A2U47	156-6668-00			IC,MISC:ECL,MISC:GENLINX CABLE DRIVER WITHTWO ADJUSTABLE OUTPUTS	37964	GS9008
A2U48	155-0416-00			IC,ASIC:BIPOLAR,VIDEO SERIALZER;FULL CUSTOM,M763	TK2598	155041600
A2U49	155-0416-00			IC,ASIC:BIPOLAR,VIDEO SERIALZER;FULL CUSTOM,M763	TK2598	155041600
A2U50	156-6059-01			IC,MISC:CMOS,ANALOG SWITCH;QUAD	1ES66	DG444DY-T
A2U51	156-5019-01			IC,LINEAR:BIPOLAR,COMPARATOR;DUAL,SINGLE SUPPLY	01295	LM393DR
A2U54	156-5018-01			IC,LINEAR:BIPOLAR,OP-AMP;DUAL,SINGLE SUPPLY	01295	LM358DR
A2U56	156-5055-01			IC,DIGITAL:FTTL,FLIP FLOP;DUAL D-TYPE	01295	SN74F74DR
A2U59	156-5055-01			IC,DIGITAL:FTTL,FLIP FLOP;DUAL D-TYPE	01295	SN74F74DR
A2U60	156-5118-01			IC,DIGITAL:FTTL,GATE:QUAD 2-INPUT NAND	01295	SN74F00DR
A2U62	156-6706-00			IC,LINEAR:BIPOLAR,OP-AMP;DUAL,HIGH OUTPUT DRIVE,LOW NOISE	1CH66	NE5532D
A2U64	156-5324-01			IC,DIGITAL:ECL,TRANSLATOR:QUAD ECL-TO-TTL	04713	MC10H125FNR2
A2U73	156-5055-01			IC,DIGITAL:FTTL,FLIP FLOP;DUAL D-TYPE	01295	SN74F74DR
A2U74	156-5118-01			IC,DIGITAL:FTTL,GATE:QUAD 2-INPUT NAND	01295	SN74F00DR
A2U76	156-6561-00			IC,CONVERTER:BIPOLAR,D/A;10 BIT,60MHZ,CURRENT OUT,LATCHED,LOW POWER,W/REFERENCE	61271	MB40760PF
A2U77	156-5138-01			IC,LINEAR:BIFET,OP-AMP;DUAL	01295	TL072CDR
A2U78	156-6613-00			IC,MISC:CMOS,SYNTHESIZER;NUMERICALLY CONT	34371	HSP45102SC-33
A2U79	156-6735-01			IC,LINEAR:BIPOLAR,OP-AMP;CURRENT FEEDBACK,65MHZ,W/ DISABLE,1 TO 10 GAIN RANGE	24355	AD810AR-REEL
A2U80	156-5070-01			IC,DIGITAL:HCTCMOS,BFR;OCTAL BFR/DRIVER, 3-STATE	0JR04	TC74HCT244AFW(E)
A2U81	156-5019-01			IC,LINEAR:BIPOLAR,COMPARATOR;DUAL,SINGLE SUPPLY	01295	LM393DR
A2U82	156-6892-00			IC,DIGITAL:CMOS,PLD:FPGA,FLEX 8000 FAMILY,8820,672 LE,148 I/O	67183	EPF8820RC208-2
A2U87	156-6273-00			IC,CONVERTER:CMOS,A/D;14-BIT,10US,SAR	24355	AD7871KP
A2U88	156-5297-01			IC,LIN:BIPOLAR,VR,ADJUST,SHUNT,100MA,2%, TL431CD,SO8.150,12MM T&R	01295	TL431CDR
A2U89	156-5908-00			IC,DIGITAL:FTTL,FLIP FLOP;DUAL D-TYPE, METASTABLE IMMUNITY	1CH66	N74F5074D
A2U91	163-0295-00			IC,DIGITAL:CMOS,PLD,EEPLD,7032,32 M/C,32 I/O,4IN,7.5NS,PRGM	80009	163-0295-00

Replaceable electrical parts list (Cont.)

Component number	Tektronix part number	Serial no. effective	Serial no. discont'd	Name & description	Mfr. code	Mfr. part number
A2U92	156-6260-00			IC,DIGITAL:FCTCMOS,BFR;OCTAL,3-STATE	61772	IDT74FCT244ATSO
A2U93	156-5055-01			IC,DIGITAL:FTTL,FLIP FLOP;DUAL D-TYPE	01295	SN74F74DR
A2U94	156-5506-00			IC,DIGITAL:FTTL,RGTR;QUAD 2-PORT	04713	MC74F399D
A2U95	156-5324-01			IC,DIGITAL:ECL,TRANSLATOR;QUAD ECL-TO-TTL	04713	MC10H125FNR2
A2U96	156-5269-01			IC,DIGITAL:ECL,RECEIVER,TRIPLE LINE RECEIVER, 10H116,PLCC20,16MM T&R	04713	MC10H116FNR2
A2U97	156-5055-01			IC,DIGITAL:FTTL,FLIP FLOP;DUAL D-TYPE	01295	SN74F74DR
A2U98	156-5506-00			IC,DIGITAL:FTTL,RGTR;QUAD 2-PORT	04713	MC74F399D
A2U99	156-5055-01			IC,DIGITAL:FTTL,FLIP FLOP;DUAL D-TYPE	01295	SN74F74DR
A2U100	156-5506-00			IC,DIGITAL:FTTL,RGTR;QUAD 2-PORT	04713	MC74F399D
A2U101	156-5324-01			IC,DIGITAL:ECL,TRANSLATOR;QUAD ECL-TO-TTL	04713	MC10H125FNR2
A2U102	156-5269-01			IC,DIGITAL:ECL,RECEIVER,TRIPLE LINE RECEIVER, 10H116,PLCC20,16MM T&R	04713	MC10H116FNR2
A2U103	156-5506-00			IC,DIGITAL:FTTL,RGTR;QUAD 2-PORT	04713	MC74F399D
A2U104	156-5324-01			IC,DIGITAL:ECL,TRANSLATOR;QUAD ECL-TO-TTL	04713	MC10H125FNR2
A2U105	156-5908-00			IC,DIGITAL:FTTL,FLIP FLOP;DUAL D-TYPE, METASTABLE IMMUNITY	1CH66	N74F5074D
A2U106	156-5908-00			IC,DIGITAL:FTTL,FLIP FLOP;DUAL D-TYPE, METASTABLE IMMUNITY	1CH66	N74F5074D
A2U107	156-5908-00			IC,DIGITAL:FTTL,FLIP FLOP;DUAL D-TYPE, METASTABLE IMMUNITY	1CH66	N74F5074D
A2U108	156-5908-00			IC,DIGITAL:FTTL,FLIP FLOP;DUAL D-TYPE, METASTABLE IMMUNITY	1CH66	N74F5074D
A2U200	671-3581-00			CKT BD ASSY:RESONATOR,SPG422	80009	671358100
	131-5998-00			CONN,HDR:PCB;MALE,RTANG,1 X 2,0.05CTR,0.230 MLG X 0.120 TAIL,TIN	55322	HTMS-102-01-T-S
A2U201	671-3581-00			CKT BD ASSY:RESONATOR,SPG422	80009	671358100
	131-5998-00			CONN,HDR:PCB;MALE,RTANG,1 X 2,0.05CTR,0.230 MLG X 0.120 TAIL,TIN	55322	HTMS-102-01-T-S
A2U500	156-5269-01			IC,DIGITAL:ECL,RECEIVER,TRIPLE LINE RECEIVER, 10H116,PLCC20,16MM T&R	04713	MC10H116FNR2
A2U501	156-6143-01			MICROCKT,DGTL:DUAL 4 CHANNEL,ANALOG MULTIPLEXER/ DEMULTIPLEXER	80009	156614301
A2U502	156-5070-01			IC,DIGITAL:HCTCMOS,BFR;OCTAL BFR/DRIVER, 3-STATE	0JR04	TC74HCT244AFW(E
A2W7	321-5051-00			RES,FXD:THICK FILM;0 OHM,1%,0.125W,TC=100 PPM	09969	CRCW1206 JUMPER
A2W8	321-5051-00			RES,FXD:THICK FILM;0 OHM,1%,0.125W,TC=100 PPM	09969	CRCW1206 JUMPER
A2W9	321-5051-00			RES,FXD:THICK FILM;0 OHM,1%,0.125W,TC=100 PPM	09969	CRCW1206 JUMPER
A2W10	321-5051-00			RES,FXD:THICK FILM;0 OHM,1%,0.125W,TC=100 PPM	09969	CRCW1206 JUMPER
A2Y1	119-1897-00			OSCILLATOR,RF:XTAL CONTROLLED,8.00MHZ,0.01%	61429	F1100H 8.000 MH
A2Y4	158-0405-00			XTAL,UNIT QTZ:6.144MHZ,+/-0.005%,PARALLEL,CL 30PF,ESR 40 OHM, PKGHC-49/U	61429	FOX061
	352-0130-01			HLDR,XTAL UNIT:STEEL TIN PL	5Y400	352-0130-01
A2Y5	158-0452-00			CRYSTAL:27.0 MHZ,20 PPM,ESR = 40 OHMS,HC49U	61429	HC49U 27.000MHZ

Replaceable electrical parts list (Cont.)

Component number	Tektronix part number	Serial no. effective	Serial no. discont'd	Name & description	Mfr. code	Mfr. part number
	352-0130-01			HLDR,XTAL UNIT:STEEL TIN PL	5Y400	352-0130-01
A2Y6	158-0452-00			CRYSTAL:27.0 MHZ,20 PPM,ESR = 40 OHMS,HC49U	61429	HC49U 27.000MHZ
	352-0130-01			HLDR,XTAL UNIT:STEEL TIN PL	5Y400	352-0130-01
A2Y7	158-0452-00			CRYSTAL:27.0 MHZ,20 PPM,ESR = 40 OHMS,HC49U	61429	HC49U 27.000MHZ
	352-0130-01			HLDR,XTAL UNIT:STEEL TIN PL	5Y400	352-0130-01

Replaceable electrical parts list

Component number	Tektronix part number	Serial no. effective	Serial no. discont'd	Name & description	Mfr. code	Mfr. part number
A2A1	119-4699-00			OVEN ASSEMBLY: TG2000	80009	119469900
A2A1C1	283-5004-00			CAP,FXD,CER:MLC;0.1UF,10%,25V,X7R,1206	TK2058	C3216X7R1E104K-
A2A1C2	283-5004-00			CAP,FXD,CER:MLC;0.1UF,10%,25V,X7R,1206	TK2058	C3216X7R1E104K-
A2A1C3	283-5042-00			CAP,FXD,CER:MLC;27PF,5%,50V,NPO,1206	TK2058	C3216C0G1H270J-
A2A1C4	283-5187-00			CAP,FXD,CER:MLC;15PF,5%,100V,NPO,1206		
A2A1C5	283-5004-00			CAP,FXD,CER:MLC;0.1UF,10%,25V,X7R,1206	TK2058	C3216X7R1E104K-
A2A1C6	283-5002-00			CAP,FXD,CER:MLC;1000PF,10%,50V,NPO,1206	TK2058	C3216COG1H102K-
A2A1C7	283-5004-00			CAP,FXD,CER:MLC;0.1UF,10%,25V,X7R,1206	TK2058	C3216X7R1E104K-
A2A1C8	281-0165-00			CAP,VAR,AIR DI:0.8-10PF,250V	91293	5201/3469
A2A1C9	283-5267-00			CAP,FXD,CER:MLC;1UF,+80%-20%,25V,Y5V,1206	04222	12063G105ZAT1A
A2A1CR1	152-5057-00			DIODE,SIG:VVC;30V,2.3PF @ 25V	04713	MMBV105GLT1
A2A1CR2	152-0843-00			DIODE,SIG:SCHTKY;SER-PAIR,20V,410MV,1.3PF	50434	HSMS-2812-T31
A2A1J1	131-5736-00			CONN,BOX:PCB;FEMALE,STR,2 X 4 ,0.1CTR,0.0335 H X 0.1 TAIL,TIN,HI-TEMP	55322	SSW-104-01-T-D
A2A1Q1	151-0429-00			XSTR,PWR:BIPOLAR,PNP;60V,4.0A,1.0MHZ,AMPL,DARLINGTON	04713	MJE700
A2A1Q2	151-5035-00			XSTR,SIG:BIPOLAR,NPN;25V,30MA,650MHZ,AMPL	04713	MMBTH10LT1
A2A1Q3	151-5035-00			XSTR,SIG:BIPOLAR,NPN;25V,30MA,650MHZ,AMPL	04713	MMBTH10LT1
A2A1R1	321-5049-00			RES,FXD:THICK FILM;1M OHM,1%,0.125W,TC=100 PPM	57668	MCR18FXEA1M
A2A1R2	321-5015-00			RES,FXD:THICK FILM;562 OHM,1%,0.125W,TC=100	50139	BCK5620FT
A2A1R3	321-5043-00			RES,FXD:THICK FILM;47.5 OHM,1%,0.125W,TC=100 PPM	57668	MCR18FWEA47E5
A2A1R4	321-5030-00			RES,FXD:THICK FILM;10.0K OHM,1%,0.125W,TC=100 PPM	50139	BCK1002FT
A2A1R5	321-5014-00			RES,FXD:THICK FILM;475 OHM,1%,0.125W,TC=100	50139	BCK4750FT
A2A1R6	321-5010-00			RES,FXD:THICK FILM;221 OHM,1%,0.125W,TC=100	50139	BCK221FT
A2A1R7	321-5025-00			RES,FXD:THICK FILM;3.92K OHM,1%,0.125W,TC=100 PPM	50139	BCK3921FT
A2A1R8	321-5000-00			RES,FXD:THICK FILM;10 OHM,1%,0.125W,TC=100 PPM	59124	RK73H2B10R0FT
A2A1R9	321-5008-00			RES,FXD:THICK FILM;150 OHM,1%,0.125W,TC=100	50139	BCK1500FT
A2A1R10	321-5020-00			RES,FXD:THICK FILM;1.5K OHM,1%,0.125W,TC=100 PPM	50139	BCK1501FT
A2A1R11	321-5012-00			RES,FXD:THICK FILM;332 OHM,1%,0.125W,TC=100	50139	BCK3320FT
A2A1R12	321-5026-00			RES,FXD:THICK FILM;4.75K OHM,1%,0.125W,TC=100 PPM	50139	BCK4751FT
A2A1RT1	307-5100-00			RES,THERMAL:50K OHM,5% NTC,-4.40/DEGREE C AT 25 DEGREES C;1206,T&R	56845	NTHS-1206N01
A2A1Y1	-----			XTAL UNIT,QTZ:13.5 MHZ,+/- 5 PPM, PARALLEL, CL=32 PF, HC-43/U PKG		

Replaceable electrical parts list

Component number	Tektronix part number	Serial no. effective	Serial no. discont'd	Name & description	Mfr. code	Mfr. part number
A3	671-3123-01		B020517	CKT BD ASSY:OUTPUT BOARD	80009	671312301
A3	671-3123-02	B020518		CKT BD ASSY:OUTPUT BOARD	80009	671312302
A3C1	283-5098-00			CAP,FXD,CER:MLC;0.1UF,+80%-20%,50V,Z5U,1206	04222	12065E104ZAT3A
A3C2	290-0963-00			CAP,FXD,ALUM:220UF,+50-20%,25WVDC,10 X12MM	55680	UVX1V221MPA
A3C3	283-5098-00			CAP,FXD,CER:MLC;0.1UF,+80%-20%,50V,Z5U,1206	04222	12065E104ZAT3A
A3C4	283-5098-00			CAP,FXD,CER:MLC;0.1UF,+80%-20%,50V,Z5U,1206	04222	12065E104ZAT3A
A3C5	283-5098-00			CAP,FXD,CER:MLC;0.1UF,+80%-20%,50V,Z5U,1206	04222	12065E104ZAT3A
A3C6	283-5098-00			CAP,FXD,CER:MLC;0.1UF,+80%-20%,50V,Z5U,1206	04222	12065E104ZAT3A
A3C7	283-5098-00			CAP,FXD,CER:MLC;0.1UF,+80%-20%,50V,Z5U,1206	04222	12065E104ZAT3A
A3C8	283-5098-00			CAP,FXD,CER:MLC;0.1UF,+80%-20%,50V,Z5U,1206	04222	12065E104ZAT3A
A3C9	283-5098-00			CAP,FXD,CER:MLC;0.1UF,+80%-20%,50V,Z5U,1206	04222	12065E104ZAT3A
A3C10	283-5098-00			CAP,FXD,CER:MLC;0.1UF,+80%-20%,50V,Z5U,1206	04222	12065E104ZAT3A
A3C11	283-5098-00			CAP,FXD,CER:MLC;0.1UF,+80%-20%,50V,Z5U,1206	04222	12065E104ZAT3A
A3C12	290-0963-00			CAP,FXD,ALUM:220UF,+50-20%,25WVDC,10 X12MM	55680	UVX1V221MPA
A3C13	290-0963-00			CAP,FXD,ALUM:220UF,+50-20%,25WVDC,10 X12MM	55680	UVX1V221MPA
A3C14	283-5098-00			CAP,FXD,CER:MLC;0.1UF,+80%-20%,50V,Z5U,1206	04222	12065E104ZAT3A
A3C15	283-5098-00			CAP,FXD,CER:MLC;0.1UF,+80%-20%,50V,Z5U,1206	04222	12065E104ZAT3A
A3C16	283-5098-00			CAP,FXD,CER:MLC;0.1UF,+80%-20%,50V,Z5U,1206	04222	12065E104ZAT3A
A3C17	283-5098-00			CAP,FXD,CER:MLC;0.1UF,+80%-20%,50V,Z5U,1206	04222	12065E104ZAT3A
A3C18	283-5098-00			CAP,FXD,CER:MLC;0.1UF,+80%-20%,50V,Z5U,1206	04222	12065E104ZAT3A
A3C19	283-5098-00			CAP,FXD,CER:MLC;0.1UF,+80%-20%,50V,Z5U,1206	04222	12065E104ZAT3A
A3C20	283-5098-00			CAP,FXD,CER:MLC;0.1UF,+80%-20%,50V,Z5U,1206	04222	12065E104ZAT3A
A3C21	283-5098-00			CAP,FXD,CER:MLC;0.1UF,+80%-20%,50V,Z5U,1206	04222	12065E104ZAT3A
A3C22	283-5098-00			CAP,FXD,CER:MLC;0.1UF,+80%-20%,50V,Z5U,1206	04222	12065E104ZAT3A
A3C23	283-5098-00			CAP,FXD,CER:MLC;0.1UF,+80%-20%,50V,Z5U,1206	04222	12065E104ZAT3A
A3C24	290-0963-00			CAP,FXD,ALUM:220UF,+50-20%,25WVDC,10 X12MM	55680	UVX1V221MPA
A3C25	283-5098-00			CAP,FXD,CER:MLC;0.1UF,+80%-20%,50V,Z5U,1206	04222	12065E104ZAT3A
A3C26	283-5098-00			CAP,FXD,CER:MLC;0.1UF,+80%-20%,50V,Z5U,1206	04222	12065E104ZAT3A
A3C27	283-5098-00			CAP,FXD,CER:MLC;0.1UF,+80%-20%,50V,Z5U,1206	04222	12065E104ZAT3A
A3C28	283-5098-00			CAP,FXD,CER:MLC;0.1UF,+80%-20%,50V,Z5U,1206	04222	12065E104ZAT3A
A3C29	283-5098-00			CAP,FXD,CER:MLC;0.1UF,+80%-20%,50V,Z5U,1206	04222	12065E104ZAT3A
A3C30	290-0963-00			CAP,FXD,ALUM:220UF,+50-20%,25WVDC,10 X12MM	55680	UVX1V221MPA
A3C32	290-1289-00			CAP,FXD,ALUM:47UF,20%,16V,0.250 X 0.276;RADIAL,NONPOLAR,BULK	55680	USP1C470MCA1TP
A3C33	283-5185-00			CAP,FXD,CER:MLC;1000PF,5%,50V,NPO,1206	04222	12065A72JAT1A
A3C34	283-0672-00			CAP,FXD,MICA DI:200PF,1%,500V	TK0891	RDM15FD201F03
A3C35	283-0634-00			CAP,FXD,MICA DI:65PF,1%,100V	TK0891	RDM15ED650F03
A3C36	283-5098-00			CAP,FXD,CER:MLC;0.1UF,+80%-20%,50V,Z5U,1206	04222	12065E104ZAT3A
A3C37	283-5098-00			CAP,FXD,CER:MLC;0.1UF,+80%-20%,50V,Z5U,1206	04222	12065E104ZAT3A

Replaceable electrical parts list (Cont.)

Component number	Tektronix part number	Serial no. effective	Serial no. discont'd	Name & description	Mfr. code	Mfr. part number
A3C38	283-5098-00			CAP,FXD,CER:MLC;0.1UF,+80%-20%,50V,Z5U,1206	04222	12065E104ZAT3A
A3C39	283-5098-00			CAP,FXD,CER:MLC;0.1UF,+80%-20%,50V,Z5U,1206	04222	12065E104ZAT3A
A3C40	283-5189-00			CAP,FXD,CER:MLC;220PF,5%,100V,NPO,1206	04222	12061A221JAT1A
A3C52	290-1289-00			CAP,FXD,ALUM:47UF,20%,16V,0.250 X 0.276;NONPOLAR	55680	USP1C470MCA1TP
A3C56	283-5189-00			CAP,FXD,CER:MLC;220PF,5%,100V,NPO,1206	04222	12061A221JAT1A
A3C57	283-5098-00		671-3123-01	CAP,FXD,CER:MLC;0.1UF,+80%-20%,50V,Z5U,1206	04222	12065E104ZAT3A
A3C57	283-5203-00	671-3123-02		CAP,FXD,CERAMIC:MLC;1000PF,10%,100V,X7R,1206,SMD	04222	12061C102KAT1A
A3C58	283-5010-00			CAP,FXD,CER:MLC;0.22UF,10%,25V,X7R,1210	TK2058	C3225X7R1E224K-
A3C60	283-5005-00			CAP,FXD,CER:MLC;4PF,+/-0.25PF,50V,NPO,1206	TK2058	C3216C0G1H040C-
A3C61	283-5005-00			CAP,FXD,CER:MLC;4PF,+/-0.25PF,50V,NPO,1206	TK2058	C3216C0G1H040C-
A3C62	283-5187-00			CAP,FXD,CER:MLC;15PF,5%,100V,NPO,1206	04222	12061A150JAT1A
A3C63	290-1289-00			CAP,FXD,ALUM:47UF,20%,16V,0.250 X 0.276;NONPOLAR	55680	USP1C470MCA1TP
A3C65	283-5003-00			CAP,FXD,CER:MLC;0.01UF,10%,50V,X7R,1206	TK2058	C3216X7R1H103K-
A3C66	283-5202-00			CAP,FXD,CER:MLC;0.022UF,10%,50V,X7R,1206,SMD,8MM	04222	12065C223KAT1A
A3C67	283-5189-00			CAP,FXD,CER:MLC;220PF,5%,100V,NPO,1206	04222	12061A221JAT1A
A3C68	283-5113-00			CAP,FXD,CER:MLC;0.047UF,10%,50V,X7R,1206	04222	12065C473KAT1A
A3C69	283-5202-00			CAP,FXD,CER:MLC;0.022UF,10%,50V,X7R,1206,SMD,8MM	04222	12065C223KAT1A
A3C70	283-5098-00			CAP,FXD,CER:MLC;0.1UF,+80%-20%,50V,Z5U,1206	04222	12065E104ZAT3A
A3C71	283-5098-00			CAP,FXD,CER:MLC;0.1UF,+80%-20%,50V,Z5U,1206	04222	12065E104ZAT3A
A3C72	283-5098-00			CAP,FXD,CER:MLC;0.1UF,+80%-20%,50V,Z5U,1206	04222	12065E104ZAT3A
A3C73	283-5098-00			CAP,FXD,CER:MLC;0.1UF,+80%-20%,50V,Z5U,1206	04222	12065E104ZAT3A
A3C74	283-5098-00			CAP,FXD,CER:MLC;0.1UF,+80%-20%,50V,Z5U,1206	04222	12065E104ZAT3A
A3C75	283-5098-00			CAP,FXD,CER:MLC;0.1UF,+80%-20%,50V,Z5U,1206	04222	12065E104ZAT3A
A3C76	283-5098-00			CAP,FXD,CER:MLC;0.1UF,+80%-20%,50V,Z5U,1206	04222	12065E104ZAT3A
A3C77	283-5098-00			CAP,FXD,CER:MLC;0.1UF,+80%-20%,50V,Z5U,1206	04222	12065E104ZAT3A
A3C78	283-5098-00			CAP,FXD,CER:MLC;0.1UF,+80%-20%,50V,Z5U,1206	04222	12065E104ZAT3A
A3C79	283-5098-00			CAP,FXD,CER:MLC;0.1UF,+80%-20%,50V,Z5U,1206	04222	12065E104ZAT3A
A3C80	283-5185-00			CAP,FXD,CER:MLC;1000PF,5%,50V,NPO,1206	04222	12065A72JAT1A
A3C81	283-5267-00			CAP,FXD,CER:MLC;1UF,+80%-20%,25V,Y5V,1206	04222	12063G105ZAT1A
A3C82	283-5267-00			CAP,FXD,CER:MLC;1UF,+80%-20%,25V,Y5V,1206	04222	12063G105ZAT1A
A3C83	283-5267-00			CAP,FXD,CER:MLC;1UF,+80%-20%,25V,Y5V,1206	04222	12063G105ZAT1A
A3C84	283-5227-00			CAP,FXD,CER:MLC;56PF,5%,100V,NPO,.120X.060	04222	12061A560JATMA
A3C85	283-5202-00			CAP,FXD,CER:MLC;0.022UF,10%,50V,X7R,1206,SMD,8MM	04222	12065C223KAT1A
A3C86	283-5201-00			CAP,FXD,CER:MLC;33PF,5%,100V,NPO,1206	04222	12061A330JAT1A
A3C87	283-5098-00			CAP,FXD,CER:MLC;0.1UF,+80%-20%,50V,Z5U,1206	04222	12065E104ZAT3A
A3C88	283-5098-00			CAP,FXD,CER:MLC;0.1UF,+80%-20%,50V,Z5U,1206	04222	12065E104ZAT3A
A3C89	283-5267-00			CAP,FXD,CER:MLC;1UF,+80%-20%,25V,Y5V,1206	04222	12063G105ZAT1A
A3C90	283-5265-00			CAP,FXD,CER:MLC;0.0033UF,5%,50V,NPO,1206	04222	12065A332JAT1A

Replaceable electrical parts list (Cont.)

Component number	Tektronix part number	Serial no. effective	Serial no. discont'd	Name & description	Mfr. code	Mfr. part number
A3C91	283-5265-00			CAP,FXD,CER:MLC;0.0033UF,5%,50V,NPO,1206	04222	12065A332JAT1A
A3C92	283-5196-00			CAP,FXD,CER:MLC;47PF,5%,100V,NPO,1206	04222	12061A470JAT1A
A3C93	283-5197-00			CAP,FXD,CER:MLC;330PF,5%,100V,NPO,1206	04222	12061A331JAT1A
A3C94	283-5267-00			CAP,FXD,CER:MLC;1UF,+80%-20%,25V,Y5V,1206	04222	12063G105ZAT1A
A3C95	283-5267-00			CAP,FXD,CER:MLC;1UF,+80%-20%,25V,Y5V,1206	04222	12063G105ZAT1A
A3C96	283-5267-00			CAP,FXD,CER:MLC;1UF,+80%-20%,25V,Y5V,1206	04222	12063G105ZAT1A
A3C97	283-5098-00			CAP,FXD,CER:MLC;0.1UF,+80%-20%,50V,Z5U,1206	04222	12065E104ZAT3A
A3C98	283-5098-00			CAP,FXD,CER:MLC;0.1UF,+80%-20%,50V,Z5U,1206	04222	12065E104ZAT3A
A3C99	283-5003-00			CAP,FXD,CER:MLC;0.01UF,10%,50V,X7R,1206	TK2058	C3216X7R1H103K-
A3C100	283-5265-00			CAP,FXD,CER:MLC;0.0033UF,5%,50V,NPO,1206	04222	12065A332JAT1A
A3C101	283-5267-00			CAP,FXD,CER:MLC;1UF,+80%-20%,25V,Y5V,1206	04222	12063G105ZAT1A
A3C102	290-0963-00			CAP,FXD,ALUM;220UF,+50-20%,25WVDC,10 X12MM	55680	UVX1V221MPA
A3C103	283-5098-00			CAP,FXD,CER:MLC;0.1UF,+80%-20%,50V,Z5U,1206	04222	12065E104ZAT3A
A3C104	283-5098-00			CAP,FXD,CER:MLC;0.1UF,+80%-20%,50V,Z5U,1206	04222	12065E104ZAT3A
A3C105	290-0963-00			CAP,FXD,ALUM;220UF,+50-20%,25WVDC,10 X12MM	55680	UVX1V221MPA
A3C106	283-5049-00			CAP,FXD,CER:MLC;180PF,5%,50V,NPO,1206	TK2058	C3216C0G1H181J-
A3C107	283-5189-00			CAP,FXD,CER:MLC;220PF,5%,100V,NPO,1206	04222	12061A221JAT1A
A3C108	283-5267-00			CAP,FXD,CER:MLC;1UF,+80%-20%,25V,Y5V,1206	04222	12063G105ZAT1A
A3C109	283-5267-00			CAP,FXD,CER:MLC;1UF,+80%-20%,25V,Y5V,1206	04222	12063G105ZAT1A
A3C110	283-5201-00			CAP,FXD,CER:MLC;33PF,5%,100V,NPO,1206	04222	12061A330JAT1A
A3C111	283-5201-00			CAP,FXD,CER:MLC;33PF,5%,100V,NPO,1206	04222	12061A330JAT1A
A3C112	283-5201-00			CAP,FXD,CER:MLC;33PF,5%,100V,NPO,1206	04222	12061A330JAT1A
A3C113	283-5201-00			CAP,FXD,CER:MLC;33PF,5%,100V,NPO,1206	04222	12061A330JAT1A
A3C114	283-5267-00			CAP,FXD,CER:MLC;1UF,+80%-20%,25V,Y5V,1206	04222	12063G105ZAT1A
A3C115	283-5267-00			CAP,FXD,CER:MLC;1UF,+80%-20%,25V,Y5V,1206	04222	12063G105ZAT1A
A3C116	283-5189-00			CAP,FXD,CER:MLC;220PF,5%,100V,NPO,1206	04222	12061A221JAT1A
A3C117	283-5098-00			CAP,FXD,CER:MLC;0.1UF,+80%-20%,50V,Z5U,1206	04222	12065E104ZAT3A
A3C119	283-5098-00			CAP,FXD,CER:MLC;0.1UF,+80%-20%,50V,Z5U,1206	04222	12065E104ZAT3A
A3C120	283-5098-00			CAP,FXD,CER:MLC;0.1UF,+80%-20%,50V,Z5U,1206	04222	12065E104ZAT3A
A3C121	283-5098-00			CAP,FXD,CER:MLC;0.1UF,+80%-20%,50V,Z5U,1206	04222	12065E104ZAT3A
A3C123	283-5188-00			CAP,FXD,CER:MLC;100PF,5%,100V,NPO,1206	04222	12061A71JAT1A
A3C124	283-5188-00			CAP,FXD,CER:MLC;100PF,5%,100V,NPO,1206	04222	12061A71JAT1A
A3C125	283-5098-00			CAP,FXD,CER:MLC;0.1UF,+80%-20%,50V,Z5U,1206	04222	12065E104ZAT3A
A3C126	283-5098-00			CAP,FXD,CER:MLC;0.1UF,+80%-20%,50V,Z5U,1206	04222	12065E104ZAT3A
A3C127	283-5098-00			CAP,FXD,CER:MLC;0.1UF,+80%-20%,50V,Z5U,1206	04222	12065E104ZAT3A
A3C128	283-5196-00			CAP,FXD,CER:MLC;47PF,5%,100V,NPO,1206	04222	12061A470JAT1A
A3C129	283-5006-00			CAP,FXD,CER:MLC;5PF,+/-0.25PF,50V,NPO,1206	TK2058	C3216C0G1H050C-
A3C130	281-5012-00			CAP,VAR,CER:5-40PF,25V,N750+/-500PPM/C,SINGLE TURN, TOP-ADJ	04222	CTZ3S-40C-W5

Replaceable electrical parts list (Cont.)

Component number	Tektronix part number	Serial no. effective	Serial no. discont'd	Name & description	Mfr. code	Mfr. part number
A3C131	283-5098-00			CAP,FXD,CER:MLC;0.1UF,+80%-20%,50V,Z5U,1206	04222	12065E104ZAT3A
A3C132	283-5098-00			CAP,FXD,CER:MLC;0.1UF,+80%-20%,50V,Z5U,1206	04222	12065E104ZAT3A
A3C133	283-5098-00			CAP,FXD,CER:MLC;0.1UF,+80%-20%,50V,Z5U,1206	04222	12065E104ZAT3A
A3C134	283-5196-00			CAP,FXD,CER:MLC;47PF,5%,100V,NPO,1206	04222	12061A470JAT1A
A3C135	283-5006-00			CAP,FXD,CER:MLC;5PF,+/-0.25PF,50V,NPO,1206	TK2058	C3216C0G1H050C-
A3C136	281-5012-00			CAP,VAR,CER:5-40PF,25V,N750+/-500PPM/C,SINGLE TURN, TOP-ADJ	04222	CTZ3S-40C-W5
A3C137	283-5098-00			CAP,FXD,CER:MLC;0.1UF,+80%-20%,50V,Z5U,1206	04222	12065E104ZAT3A
A3C138	283-5098-00			CAP,FXD,CER:MLC;0.1UF,+80%-20%,50V,Z5U,1206	04222	12065E104ZAT3A
A3C139	283-5098-00			CAP,FXD,CER:MLC;0.1UF,+80%-20%,50V,Z5U,1206	04222	12065E104ZAT3A
A3C140	283-5098-00			CAP,FXD,CER:MLC;0.1UF,+80%-20%,50V,Z5U,1206	04222	12065E104ZAT3A
A3C141	283-5098-00			CAP,FXD,CER:MLC;0.1UF,+80%-20%,50V,Z5U,1206	04222	12065E104ZAT3A
A3C142	283-5098-00			CAP,FXD,CER:MLC;0.1UF,+80%-20%,50V,Z5U,1206	04222	12065E104ZAT3A
A3C143	283-5098-00			CAP,FXD,CER:MLC;0.1UF,+80%-20%,50V,Z5U,1206	04222	12065E104ZAT3A
A3C144	283-5098-00			CAP,FXD,CER:MLC;0.1UF,+80%-20%,50V,Z5U,1206	04222	12065E104ZAT3A
A3C145	283-5098-00			CAP,FXD,CER:MLC;0.1UF,+80%-20%,50V,Z5U,1206	04222	12065E104ZAT3A
A3C146	283-5098-00			CAP,FXD,CER:MLC;0.1UF,+80%-20%,50V,Z5U,1206	04222	12065E104ZAT3A
A3C147	283-5098-00			CAP,FXD,CER:MLC;0.1UF,+80%-20%,50V,Z5U,1206	04222	12065E104ZAT3A
A3C148	283-5098-00			CAP,FXD,CER:MLC;0.1UF,+80%-20%,50V,Z5U,1206	04222	12065E104ZAT3A
A3C149	283-5098-00			CAP,FXD,CER:MLC;0.1UF,+80%-20%,50V,Z5U,1206	04222	12065E104ZAT3A
A3C150	283-5098-00			CAP,FXD,CER:MLC;0.1UF,+80%-20%,50V,Z5U,1206	04222	12065E104ZAT3A
A3C151	283-5098-00			CAP,FXD,CER:MLC;0.1UF,+80%-20%,50V,Z5U,1206	04222	12065E104ZAT3A
A3C152	283-5098-00			CAP,FXD,CER:MLC;0.1UF,+80%-20%,50V,Z5U,1206	04222	12065E104ZAT3A
A3C153	283-5098-00			CAP,FXD,CER:MLC;0.1UF,+80%-20%,50V,Z5U,1206	04222	12065E104ZAT3A
A3C154	283-5098-00			CAP,FXD,CER:MLC;0.1UF,+80%-20%,50V,Z5U,1206	04222	12065E104ZAT3A
A3C155	283-5098-00			CAP,FXD,CER:MLC;0.1UF,+80%-20%,50V,Z5U,1206	04222	12065E104ZAT3A
A3C156	283-5098-00			CAP,FXD,CER:MLC;0.1UF,+80%-20%,50V,Z5U,1206	04222	12065E104ZAT3A
A3C157	283-5098-00			CAP,FXD,CER:MLC;0.1UF,+80%-20%,50V,Z5U,1206	04222	12065E104ZAT3A
A3C158	283-5098-00			CAP,FXD,CER:MLC;0.1UF,+80%-20%,50V,Z5U,1206	04222	12065E104ZAT3A
A3C159	283-5098-00			CAP,FXD,CER:MLC;0.1UF,+80%-20%,50V,Z5U,1206	04222	12065E104ZAT3A
A3C160	283-5098-00			CAP,FXD,CER:MLC;0.1UF,+80%-20%,50V,Z5U,1206	04222	12065E104ZAT3A
A3C161	283-5098-00			CAP,FXD,CER:MLC;0.1UF,+80%-20%,50V,Z5U,1206	04222	12065E104ZAT3A
A3C162	283-5098-00			CAP,FXD,CER:MLC;0.1UF,+80%-20%,50V,Z5U,1206	04222	12065E104ZAT3A
A3C163	283-5098-00			CAP,FXD,CER:MLC;0.1UF,+80%-20%,50V,Z5U,1206	04222	12065E104ZAT3A
A3C164	283-5098-00			CAP,FXD,CER:MLC;0.1UF,+80%-20%,50V,Z5U,1206	04222	12065E104ZAT3A
A3C165	283-5098-00			CAP,FXD,CER:MLC;0.1UF,+80%-20%,50V,Z5U,1206	04222	12065E104ZAT3A
A3C166	283-5098-00			CAP,FXD,CER:MLC;0.1UF,+80%-20%,50V,Z5U,1206	04222	12065E104ZAT3A
A3C167	283-5098-00			CAP,FXD,CER:MLC;0.1UF,+80%-20%,50V,Z5U,1206	04222	12065E104ZAT3A
A3C168	283-5098-00			CAP,FXD,CER:MLC;0.1UF,+80%-20%,50V,Z5U,1206	04222	12065E104ZAT3A

Replaceable electrical parts list (Cont.)

Component number	Tektronix part number	Serial no. effective	Serial no. discont'd	Name & description	Mfr. code	Mfr. part number
A3C169	283-5098-00			CAP,FXD,CER:MLC:0.1UF,+80%-20%,50V,Z5U,1206	04222	12065E104ZAT3A
A3C170	283-5098-00			CAP,FXD,CER:MLC:0.1UF,+80%-20%,50V,Z5U,1206	04222	12065E104ZAT3A
A3C180	283-5267-00	671-3123-02		CAP,FXD,CERAMIC:MLC,1UF,+80%-20%,25V,Y5V,1206	04222	12063G105ZAT4A
A3C181	283-5106-00	671-3123-02		CAP,FXD,CERAMIC:MLC,470PF,5%,100V,NPO,1206	04222	12061A471JAT1A
A3C1000	283-5098-00			CAP,FXD,CER:MLC:0.1UF,+80%-20%,50V,Z5U,1206	04222	12065E104ZAT3A
A3C1001	283-5042-00			CAP,FXD,CER:MLC:27PF,5%,50V,NPO,1206	TK2058	C3216C0G1H270J-
A3C1002	283-5189-00			CAP,FXD,CER:MLC:220PF,5%,100V,NPO,1206	04222	12061A221JAT1A
A3C1003	283-5189-00			CAP,FXD,CER:MLC:220PF,5%,100V,NPO,1206	04222	12061A221JAT1A
A3C1004	283-5098-00			CAP,FXD,CER:MLC:0.1UF,+80%-20%,50V,Z5U,1206	04222	12065E104ZAT3A
A3C1009	290-5034-01			CAP,FXD,ALUM:33UF,20%,10V,5.7MM(0.224)	62643	MVK10VC33RME60T
A3C1010	283-5187-00			CAP,FXD,CER:MLC:15PF,5%,100V,NPO,1206	04222	12061A150JAT1A
A3C1012	283-5187-00			CAP,FXD,CER:MLC:15PF,5%,100V,NPO,1206	04222	12061A150JAT1A
A3C1013	290-0963-00			CAP,FXD,ALUM:220UF,+50-20%,25WVDC,10 X12MM	55680	UVX1V221MPA
A3C1014	283-5098-00			CAP,FXD,CER:MLC:0.1UF,+80%-20%,50V,Z5U,1206	04222	12065E104ZAT3A
A3C1015	283-5098-00			CAP,FXD,CER:MLC:0.1UF,+80%-20%,50V,Z5U,1206	04222	12065E104ZAT3A
A3C1016	283-5098-00			CAP,FXD,CER:MLC:0.1UF,+80%-20%,50V,Z5U,1206	04222	12065E104ZAT3A
A3C1017	283-5098-00			CAP,FXD,CER:MLC:0.1UF,+80%-20%,50V,Z5U,1206	04222	12065E104ZAT3A
A3C1018	283-5098-00			CAP,FXD,CER:MLC:0.1UF,+80%-20%,50V,Z5U,1206	04222	12065E104ZAT3A
A3C1019	283-5098-00			CAP,FXD,CER:MLC:0.1UF,+80%-20%,50V,Z5U,1206	04222	12065E104ZAT3A
A3C1020	283-5098-00			CAP,FXD,CER:MLC:0.1UF,+80%-20%,50V,Z5U,1206	04222	12065E104ZAT3A
A3C1021	283-5098-00			CAP,FXD,CER:MLC:0.1UF,+80%-20%,50V,Z5U,1206	04222	12065E104ZAT3A
A3C1022	283-5098-00			CAP,FXD,CER:MLC:0.1UF,+80%-20%,50V,Z5U,1206	04222	12065E104ZAT3A
A3C1023	283-5098-00			CAP,FXD,CER:MLC:0.1UF,+80%-20%,50V,Z5U,1206	04222	12065E104ZAT3A
A3CR1	152-5038-00			DIODE,SIG:30V,1.5PF,VF = 600MV @ 10MA	04713	MMBD301LT1
A3CR2	152-5062-00		671-3123-01	DIO,SIG:ULTRA FAST;100V,0.74VF,4NS,2.0PF,COM-ANODE	27014	MMBD1205
A3CR2	152-5018-00	671-3123-02		DIODE,SIG:ULTRA FAST,100V,0.74VF,4NS,2.0PF,SER-PAIR	07263	MMBD1203
A3CR3	152-5018-00			DIODE,SIG:ULTRA FAST,100V,0.74VF,4NS,2.0PF,SER-PAIR	07263	MMBD1203
A3CR4	152-5018-00	671-3123-02		DIODE,SIG:ULTRA FAST;100V,0.74VF,4NS,2.0PF,SER-PAIR	07263	MMBD1203
A3CR5	152-0843-00			DIODE,SIG:SCHTKY;SER-PAIR,20V,410MV,1.3PF	50434	HSMS-2812-T31
A3CR6	152-0843-00			DIODE,SIG:SCHTKY;SER-PAIR,20V,410MV,1.3PF	50434	HSMS-2812-T31
A3CR7	152-5038-00			DIODE,SIG:30V,1.5PF,VF = 600MV @ 10MA	04713	MMBD301LT1
A3CR8	152-5038-00			DIODE,SIG:30V,1.5PF,VF = 600MV @ 10MA	04713	MMBD301LT1
A3CR9	152-5038-00			DIODE,SIG:30V,1.5PF,VF = 600MV @ 10MA	04713	MMBD301LT1
A3CR10	152-5038-00			DIODE,SIG:30V,1.5PF,VF = 600MV @ 10MA	04713	MMBD301LT1
A3CR11	152-0843-00			DIODE,SIG:SCHTKY;SER-PAIR,20V,410MV,1.3PF	50434	HSMS-2812-T31
A3CR12	152-5062-00			DIO,SIG:ULTRA FAST;100V,0.74VF,4NS,2.0PF,COM-ANODE	27014	MMBD1205
A3CR13	152-5062-00			DIO,SIG:ULTRA FAST;100V,0.74VF,4NS,2.0PF,COM-ANODE	27014	MMBD1205
A3CR14	152-5062-00			DIO,SIG:ULTRA FAST;100V,0.74VF,4NS,2.0PF,COM-ANODE	27014	MMBD1205

Replaceable electrical parts list (Cont.)

Component number	Tektronix part number	Serial no. effective	Serial no. discont'd	Name & description	Mfr. code	Mfr. part number
A3CR15	152-0845-00			DIODE,SIG:SCHTKY;COM-CATH,20V,410MV,1.3PF	50434	HSMS-2814-T31
A3FL2	119-4316-00			FILTER,LOWPASS:PCB,SIP;DELAY EQUALIZED,6MHZ	19615	F4105
A3FL3	119-4316-00			FILTER,LOWPASS:PCB,SIP;DELAY EQUALIZED,6MHZ	19615	F4105
A3J1	131-3323-00			CONN,HDR:PCB;MALE,STR,2 X 20,0.1 CTR,0.365D	22526	66506-025
A3J2	131-3323-00			CONN,HDR:PCB;MALE,STR,2 X 20,0.1 CTR,0.365D	22526	66506-025
A3J3	131-3378-00			CONN,RF JACK:BNC;50 OHM,FEMALE,RTANG,PCB/REAR PNL,0.5-28 THD,0.625 H X 0.187 TAIL,W/O	00779	227677-1
A3J4	131-3378-00			CONN,RF JACK:BNC;50 OHM,FEMALE,RTANG,PCB/REAR PNL,0.5-28 THD,0.625 H X 0.187 TAIL,W/O	00779	227677-1
A3J5	131-4530-00			CONN,HDR:PCB;MALE,STR,1 X 3,0.1 CTR,0.230 MLG X 0.120 TAIL,30GOLD,BD RETENTION	00779	104344-1
A3J6	131-4530-00			CONN,HDR:PCB;MALE,STR,1 X 3,0.1 CTR,0.230 MLG X 0.120 TAIL,30GOLD,BD RETENTION	00779	104344-1
A3J7	131-4917-00			CONN,HDR:PCB;MALE,STR,1 X 2,0.1 CTR,0.235 MLG X 0.110 TAIL,30GOLD,TUBE,HIGH TEMP	00779	104714-3
A3J8	131-4917-00			CONN,HDR:PCB;MALE,STR,1 X 2,0.1 CTR,0.235 MLG X 0.110 TAIL,30GOLD,TUBE,HIGH TEMP	00779	104714-3
A3J9	131-3378-00			CONN,RF JACK:BNC;50 OHM,FEMALE,RTANG,PCB/REAR PNL,0.5-28 THD,0.625 H X 0.187 TAIL,W/O	00779	227677-1
A3J10	131-3378-00			CONN,RF JACK:BNC;50 OHM,FEMALE,RTANG,PCB/REAR PNL,0.5-28 THD,0.625 H X 0.187 TAIL,W/O	00779	227677-1
A3K1	148-0148-00		671-3123-01	RELAY,ARMATURE:2 FORM C,COIL 5 VDC 62.5 OHM,CONTACT 220 VDC 2A 60W, PKG 0.787 X 0.39, 0.366 HI	61529	DS2E-M-DC5V
A3K1	148-0255-00	671-3123-02		RELAY,LATCHING, DPDT	61529	DS2E-M-DC5V
A3L1	108-1557-00			INDUCTOR,FXD:CUSTOM,SIGNAL;15UH,10%,IDC<5.0	0JR03	108-1557-00
A3L2	108-1557-00			INDUCTOR,FXD:CUSTOM,SIGNAL;15UH,10%,IDC<5.0	0JR03	108-1557-00
A3L3	108-0550-00			INDUCTOR,FXD:CUSTOM,SIGNAL;89NH,Q>39@50MHZ, ON FORM 276-0153-00	0JR03	108-0550-00
A3L4	108-0550-00			INDUCTOR,FXD:CUSTOM,SIGNAL;89NH,Q>39@50MHZ, ON FORM 276-0153-00	0JR03	108-0550-00
A3L6	108-5014-00			INDUCTOR,FXD:SIGNAL;820UH,5%,I<30MA,RDC<35 OHM,Q>30,SRF>3.0MHZ	TK2058	NL453232T-821J-
A3L7	108-5015-00			INDUCTOR,FXD:SIGNAL;100UH,10%,I<0.11A,RDC<8.0 OHM,Q>40,SRF>8.0 MHZ	TK2058	NL453232T-101K
A3L8	108-5051-00			INDUCTOR,FXD:SIGNAL;10UH,10%,I<0.25A,RDC<1.6 OHM,Q>50,SRF>20MHZ	TK2058	NL453232T-100K
A3L9	108-5051-00			INDUCTOR,FXD:SIGNAL;10UH,10%,I<0.25A,RDC<1.6 OHM,Q>50,SRF>20MHZ	TK2058	NL453232T-100K
A3L10	108-5014-00			INDUCTOR,FXD:SIGNAL;820UH,5%,I<30MA,RDC<35 OHM,Q>30,SRF>3.0MHZ	TK2058	NL453232T-821J-
A3L11	108-5124-01			INDUCTOR,FXD:POWER;1.0UH,10%,IDC<1.05 A,RDC <0.11 OHM,Q>10,SRF>200 MHZ	TK2058	NLC453232T-1R0K
A3L12	108-5124-01			INDUCTOR,FXD:POWER;1.0UH,10%,IDC<1.05 A,RDC <0.11 OHM,Q>10,SRF>200 MHZ	TK2058	NLC453232T-1R0K

Replaceable electrical parts list (Cont.)

Component number	Tektronix part number	Serial no. effective	Serial no. discont'd	Name & description	Mfr. code	Mfr. part number
A3L13	108-5120-00			INDUCTOR,FXD:SIGNAL:56UH,10%,IDC<135 MA,RDC<5.5 OHM,Q>50,SRF>9 MHZ	09969	IMC-1812-56UH-1
A3L14	108-5120-00			INDUCTOR,FXD:SIGNAL:56UH,10%,IDC<135 MA,RDC<5.5 OHM,Q>50,SRF>9 MHZ	09969	IMC-1812-56UH-1
A3Q1	151-5001-00			XSTR,SIG:BIPOLAR,NPN;40V,200MA,300MHZ,AMPLIFIER	04713	MMBT3904LT1
A3Q2	151-5035-00			XSTR,SIG:BIPOLAR,NPN;25V,30MA,650MHZ,AMPL	04713	MMBT10LT1
A3Q3	151-5001-00			XSTR,SIG:BIPOLAR,NPN;40V,200MA,300MHZ,AMPLIFIER	04713	MMBT3904LT1
A3Q4	151-5001-00			XSTR,SIG:BIPOLAR,NPN;40V,200MA,300MHZ,AMPLIFIER	04713	MMBT3904LT1
A3Q5	151-5021-00			XSTR,SIG:BIPOLAR,NPN;40V,600MA,300MHZ,AMPLIFIER	04713	MMBT2222ALT1
A3Q6	151-5001-00			XSTR,SIG:BIPOLAR,NPN;40V,200MA,300MHZ,AMPLIFIER	04713	MMBT3904LT1
A3Q7	151-5000-00			XSTR,SIG:BIPOLAR,PNP;40V,200MA,250MHZ,AMPLIFIER	04713	MMBT3906LT1
A3Q8	151-5001-00			XSTR,SIG:BIPOLAR,NPN;40V,200MA,300MHZ,AMPLIFIER	04713	MMBT3904LT1
A3Q9	151-5001-00			XSTR,SIG:BIPOLAR,NPN;40V,200MA,300MHZ,AMPLIFIER	04713	MMBT3904LT1
A3Q10	151-5001-00			XSTR,SIG:BIPOLAR,NPN;40V,200MA,300MHZ,AMPLIFIER	04713	MMBT3904LT1
A3Q11	151-5001-00	671-3123-02		XSTR,SIG:BIPOLAR,NPN;40V,200MA,300MHZ,AMPLIFIER	04713	MMBT3904LT1
A3Q12	151-5030-00	671-3123-02		XSTR,SIG:BIPOLAR,NPN;60V,600MA,200MHZ,AMPLIFIER	04713	MMBT2907ALT1
A3Q16	151-5002-00			XSTR,SIG:JFET,N-CH;5V,75MA,60 OHM,SWITCH	04713	MMBF4392LT1
A3Q17	151-5000-00			XSTR,SIG:BIPOLAR,PNP;40V,200MA,250MHZ,AMPLIFIER	04713	MMBT3906LT1
A3Q18	151-5000-00			XSTR,SIG:BIPOLAR,PNP;40V,200MA,250MHZ,AMPLIFIER	04713	MMBT3906LT1
A3Q19	151-5001-00			XSTR,SIG:BIPOLAR,NPN;40V,200MA,300MHZ,AMPLIFIER	04713	MMBT3904LT1
A3Q20	151-5001-00			XSTR,SIG:BIPOLAR,NPN;40V,200MA,300MHZ,AMPLIFIER	04713	MMBT3904LT1
A3Q21	151-5001-00			XSTR,SIG:BIPOLAR,NPN;40V,200MA,300MHZ,AMPLIFIER	04713	MMBT3904LT1
A3R1	321-5006-00			RES,FXD:THICK FILM;100 OHM,1%,0.125W,TC=100	50139	BCK1000FT
A3R2	321-5008-00			RES,FXD:THICK FILM;150 OHM,1%,0.125W,TC=100	50139	BCK1500FT
A3R3	321-5006-00			RES,FXD:THICK FILM;100 OHM,1%,0.125W,TC=100	50139	BCK1000FT
A3R4	321-5008-00			RES,FXD:THICK FILM;150 OHM,1%,0.125W,TC=100	50139	BCK1500FT
A3R5	321-5006-00			RES,FXD:THICK FILM;100 OHM,1%,0.125W,TC=100	50139	BCK1000FT
A3R6	321-5008-00			RES,FXD:THICK FILM;150 OHM,1%,0.125W,TC=100	50139	BCK1500FT
A3R7	321-5006-00			RES,FXD:THICK FILM;100 OHM,1%,0.125W,TC=100	50139	BCK1000FT
A3R8	321-5008-00			RES,FXD:THICK FILM;150 OHM,1%,0.125W,TC=100	50139	BCK1500FT
A3R10	321-5047-00			RES,FXD:THICK FILM;100K OHM,1%,0.125W,TC=100 PPM	50139	BCK1003FT
A3R11	321-5022-00			RES,FXD:THICK FILM;2.21K OHM,1%,0.125W,TC=100 PPM	50139	BCK2211FT
A3R12	321-5022-00		671-3123-01	RES,FXD:THICK FILM;2.21K OHM,1%,0.125W,TC=100 PPM	50139	BCK2211FT
A3R12	321-5024-00	671-3123-02		RES,FXD:THICK FILM;3.321K OHM,1%,0.125W,TC=100 PPM	50139	BCK3321FT
A3R13	321-5022-00		671-3123-01	RES,FXD:THICK FILM;2.21K OHM,1%,0.125W,TC=100 PPM	50139	BCK2211FT
A3R13	321-5027-00	671-3123-02		RES,FXD:THICK FILM;5.62K OHM,1%,0.125W,TC=100 PPM	50139	BCK3321FT
A3R14	321-5008-00			RES,FXD:THICK FILM;150 OHM,1%,0.125W,TC=100	50139	BCK1500FT
A3R15	321-5008-00			RES,FXD:THICK FILM;150 OHM,1%,0.125W,TC=100	50139	BCK1500FT
A3R16	321-5030-00			RES,FXD:THICK FILM;10.0K OHM,1%,0.125W,TC=100 PPM	50139	BCK1002FT

Replaceable electrical parts list (Cont.)

Component number	Tektronix part number	Serial no. effective	Serial no. discont'd	Name & description	Mfr. code	Mfr. part number
A3R17	321-5030-00			RES,FXD:THICK FILM;10.0K OHM,1%,0.125W,TC=100 PPM	50139	BCK1002FT
A3R18	321-5030-00			RES,FXD:THICK FILM;10.0K OHM,1%,0.125W,TC=100 PPM	50139	BCK1002FT
A3R19	321-5030-00			RES,FXD:THICK FILM;10.0K OHM,1%,0.125W,TC=100 PPM	50139	BCK1002FT
A3R24	321-5047-00			RES,FXD:THICK FILM;100K OHM,1%,0.125W,TC=100 PPM	50139	BCK1003FT
A3R25	321-5030-00			RES,FXD:THICK FILM;10.0K OHM,1%,0.125W,TC=100 PPM	50139	BCK1002FT
A3R26	321-5016-00			RES,FXD:THICK FILM;681 OHM,1%,0.125W,TC=100	50139	BCK6810FT
A3R27	321-5014-00			RES,FXD:THICK FILM;475 OHM,1%,0.125W,TC=100	50139	BCK4750FT
A3R30	321-5018-00			RES,FXD:THICK FILM;1.0K OHM,1%,0.125W,TC=100 PPM	50139	BCK1001FT
A3R31	321-5016-00			RES,FXD:THICK FILM;681 OHM,1%,0.125W,TC=100	50139	BCK6810FT
A3R32	321-5030-00			RES,FXD:THICK FILM;10.0K OHM,1%,0.125W,TC=100 PPM	50139	BCK1002FT
A3R33	321-5022-00			RES,FXD:THICK FILM;2.21K OHM,1%,0.125W,TC=100 PPM	50139	BCK2211FT
A3R34	321-5022-00			RES,FXD:THICK FILM;2.21K OHM,1%,0.125W,TC=100 PPM	50139	BCK2211FT
A3R35	321-5018-00			RES,FXD:THICK FILM;1.0K OHM,1%,0.125W,TC=100 PPM	50139	BCK1001FT
A3R36	321-5026-00			RES,FXD:THICK FILM;4.75K OHM,1%,0.125W,TC=100 PPM	50139	BCK4751FT
A3R37	321-5014-00			RES,FXD:THICK FILM;475 OHM,1%,0.125W,TC=100	50139	BCK4750FT
A3R40	321-5020-00			RES,FXD:THICK FILM;1.5K OHM,1%,0.125W,TC=100 PPM	50139	BCK1501FT
A3R41	321-5020-00			RES,FXD:THICK FILM;1.5K OHM,1%,0.125W,TC=100 PPM	50139	BCK1501FT
A3R46	321-5032-00			RES,FXD:THICK FILM;15.0K OHM,1%,0.125W,TC=100 PPM	50139	BCK1502FT
A3R47	321-5018-00		671-3123-01	RES,FXD:THICK FILM;1.0K OHM,1%,0.125W,TC=100 PPM	50139	BCK1001FT
A3R47	321-5019-00	671-3123-02		RES,FXD:THICK FILM;1.21K OHM,1%,0.125W,TC=100 PPM	50139	BCK1211FT
A3R53	321-5004-00			RES,FXD:THICK FILM;22.1 OHM,1%,0.125W,TC=100 PPM	57668	MCR18FWEA22E1
A3R54	321-5004-00			RES,FXD:THICK FILM;22.1 OHM,1%,0.125W,TC=100 PPM	57668	MCR18FWEA22E1
A3R56	322-3085-07			RES,FXD:METAL FILM;75 OHM,0.1%,0.2W,TC=25 PPM	91637	CCF502-C75ROOBT
A3R57	322-3085-07			RES,FXD:METAL FILM;75 OHM,0.1%,0.2W,TC=25 PPM	91637	CCF502-C75ROOBT
A3R58	321-5032-00			RES,FXD:THICK FILM;15.0K OHM,1%,0.125W,TC=100 PPM	50139	BCK1502FT
A3R59	321-5050-00			RES,FXD:THICK FILM;33.2 OHM,1%,0.125W,TC=100 PPM	57668	MCR18FWEA33E2
A3R60	321-5050-00			RES,FXD:THICK FILM;33.2 OHM,1%,0.125W,TC=100 PPM	57668	MCR18FWEA33E2
A3R61	321-5047-00			RES,FXD:THICK FILM;100K OHM,1%,0.125W,TC=100 PPM	50139	BCK1003FT
A3R62	321-5016-00			RES,FXD:THICK FILM;681 OHM,1%,0.125W,TC=100	50139	BCK6810FT
A3R63	321-5016-00			RES,FXD:THICK FILM;681 OHM,1%,0.125W,TC=100	50139	BCK6810FT
A3R64	321-5016-00			RES,FXD:THICK FILM;681 OHM,1%,0.125W,TC=100	50139	BCK6810FT
A3R65	321-5016-00			RES,FXD:THICK FILM;681 OHM,1%,0.125W,TC=100	50139	BCK6810FT
A3R69	321-5036-00			RES,FXD:THICK FILM;33.2K OHM,1%,0.125W,TC=100 PPM	50139	BCK3322FT
A3R70	321-5035-00			RES,FXD:THICK FILM;27.4K OHM,1%,0.125W,TC=100 PPM	50139	BCK2742FT
A3R71	321-5035-00			RES,FXD:THICK FILM;27.4K OHM,1%,0.125W,TC=100 PPM	50139	BCK2742FT
A3R72	321-5281-00			RES,FXD:THICK FILM;2K OHM,1%,0.125W,TC=100 PPM	59124	RK73H2B2001FT
A3R73	321-5024-00			RES,FXD:THICK FILM;3.32K OHM,1%,0.125W,TC=100 PPM	50139	BCK3321FT
A3R74	321-5016-00			RES,FXD:THICK FILM;681 OHM,1%,0.125W,TC=100	50139	BCK6810FT

Replaceable electrical parts list (Cont.)

Component number	Tektronix part number	Serial no. effective	Serial no. discont'd	Name & description	Mfr. code	Mfr. part number
A3R75	321-5010-00			RES,FXD:THICK FILM;221 OHM,1%,0.125W,TC=100	50139	BCK221FT
A3R76	321-5006-00			RES,FXD:THICK FILM;100 OHM,1%,0.125W,TC=100	50139	BCK1000FT
A3R77	321-5010-00			RES,FXD:THICK FILM;221 OHM,1%,0.125W,TC=100	50139	BCK221FT
A3R78	321-5006-00			RES,FXD:THICK FILM;100 OHM,1%,0.125W,TC=100	50139	BCK1000FT
A3R79	321-5006-00			RES,FXD:THICK FILM;100 OHM,1%,0.125W,TC=100	50139	BCK1000FT
A3R80	321-5049-00			RES,FXD:THICK FILM;1M OHM,1%,0.125W,TC=100 PPM	57668	MCR18FXEA1M
A3R81	321-5014-00			RES,FXD:THICK FILM;475 OHM,1%,0.125W,TC=100	50139	BCK4750FT
A3R82	321-5030-00			RES,FXD:THICK FILM;10.0K OHM,1%,0.125W,TC=100 PPM	50139	BCK1002FT
A3R83	321-5024-00			RES,FXD:THICK FILM;3.32K OHM,1%,0.125W,TC=100 PPM	50139	BCK3321FT
A3R84	321-5030-00			RES,FXD:THICK FILM;10.0K OHM,1%,0.125W,TC=100 PPM	50139	BCK1002FT
A3R85	321-5024-00			RES,FXD:THICK FILM;3.32K OHM,1%,0.125W,TC=100 PPM	50139	BCK3321FT
A3R86	321-5022-00			RES,FXD:THICK FILM;2.21K OHM,1%,0.125W,TC=100 PPM	50139	BCK2211FT
A3R87	321-5012-00			RES,FXD:THICK FILM;332 OHM,1%,0.125W,TC=100	50139	BCK3320FT
A3R88	321-5022-00			RES,FXD:THICK FILM;2.21K OHM,1%,0.125W,TC=100 PPM	50139	BCK2211FT
A3R89	321-5166-00			RES,FXD:THICK FILM;150K OHM,1%,0.125W,TC=100 PPM	59124	RK73H2B1503FT
A3R90	321-5040-00			RES,FXD:THICK FILM;68.1K OHM,1%,0.125W,TC=100 PPM	50139	BCK6812FT
A3R91	321-5040-00			RES,FXD:THICK FILM;68.1K OHM,1%,0.125W,TC=100 PPM	50139	BCK6812FT
A3R92	321-5030-00			RES,FXD:THICK FILM;10.0K OHM,1%,0.125W,TC=100 PPM	50139	BCK1002FT
A3R93	321-5030-00			RES,FXD:THICK FILM;10.0K OHM,1%,0.125W,TC=100 PPM	50139	BCK1002FT
A3R94	321-5038-00			RES,FXD:THICK FILM;47.5K OHM,1%,0.125W,TC=100 PPM	50139	BCK4752FT
A3R95	321-5166-00			RES,FXD:THICK FILM;150K OHM,1%,0.125W,TC=100 PPM	59124	RK73H2B1503FT
A3R96	321-5047-00			RES,FXD:THICK FILM;100K OHM,1%,0.125W,TC=100 PPM	50139	BCK1003FT
A3R97	321-5018-00			RES,FXD:THICK FILM;1.0K OHM,1%,0.125W,TC=100 PPM	50139	BCK1001FT
A3R98	321-5022-00			RES,FXD:THICK FILM;2.21K OHM,1%,0.125W,TC=100 PPM	50139	BCK2211FT
A3R99	321-5029-00			RES,FXD:THICK FILM;8.25K OHM,1%,0.125W,TC=100 PPM	50139	BCK8251FT
A3R100	321-5029-00			RES,FXD:THICK FILM;8.25K OHM,1%,0.125W,TC=100 PPM	50139	BCK8251FT
A3R101	321-5022-00			RES,FXD:THICK FILM;2.21K OHM,1%,0.125W,TC=100 PPM	50139	BCK2211FT
A3R102	321-5019-00			RES,FXD:THICK FILM;1.21K OHM,1%,0.125W,TC=100 PPM	50139	BCK1211FT
A3R103	321-5022-00			RES,FXD:THICK FILM;2.21K OHM,1%,0.125W,TC=100 PPM	50139	BCK2211FT
A3R104	321-5018-00			RES,FXD:THICK FILM;1.0K OHM,1%,0.125W,TC=100 PPM	50139	BCK1001FT
A3R105	321-5030-00			RES,FXD:THICK FILM;10.0K OHM,1%,0.125W,TC=100 PPM	50139	BCK1002FT
A3R106	321-5167-00			RES,FXD:THICK FILM;221K OHM,1%,0.125W,TC=100 PPM	59124	RK73H2B2213FT
A3R107	321-5024-00			RES,FXD:THICK FILM;3.32K OHM,1%,0.125W,TC=100 PPM	50139	BCK3321FT
A3R108	321-5006-00			RES,FXD:THICK FILM;100 OHM,1%,0.125W,TC=100	50139	BCK1000FT
A3R109	321-5006-00			RES,FXD:THICK FILM;100 OHM,1%,0.125W,TC=100	50139	BCK1000FT
A3R111	321-5017-00			RES,FXD:THICK FILM;825 OHM,1%,0.125W,TC=100	50139	BCK8250FT
A3R114	321-5000-00			RES,FXD:THICK FILM;10 OHM,1%,0.125W,TC=100 PPM	59124	RK73H2B10R0FT
A3R115	321-5000-00			RES,FXD:THICK FILM;10 OHM,1%,0.125W,TC=100 PPM	59124	RK73H2B10R0FT

Replaceable electrical parts list (Cont.)

Component number	Tektronix part number	Serial no. effective	Serial no. discont'd	Name & description	Mfr. code	Mfr. part number
A3R116	321-5042-00			RES,FXD:THICK FILM;39.2 OHM,1%,0.125W,TC=100 PPM	57668	MCR18EZHMF39R2
A3R117	321-5042-00			RES,FXD:THICK FILM;39.2 OHM,1%,0.125W,TC=100 PPM	57668	MCR18EZHMF39R2
A3R118	321-5042-00			RES,FXD:THICK FILM;39.2 OHM,1%,0.125W,TC=100 PPM	57668	MCR18EZHMF39R2
A3R119	321-5042-00			RES,FXD:THICK FILM;39.2 OHM,1%,0.125W,TC=100 PPM	57668	MCR18EZHMF39R2
A3R120	321-5017-00			RES,FXD:THICK FILM;825 OHM,1%,0.125W,TC=100	50139	BCK8250FT
A3R121	321-5008-00			RES,FXD:THICK FILM;150 OHM,1%,0.125W,TC=100	50139	BCK1500FT
A3R123	321-5113-00			RES,FXD:THICK FILM;75 OHM,1%,0.125W,TC=100 PPM	56845	CRCW1206-75ROFT
A3R124	321-5113-00			RES,FXD:THICK FILM;75 OHM,1%,0.125W,TC=100 PPM	56845	CRCW1206-75ROFT
A3R132	321-5008-00			RES,FXD:THICK FILM;150 OHM,1%,0.125W,TC=100	50139	BCK1500FT
A3R135	321-5009-00			RES,FXD:THICK FILM;182 OHM,1%,0.125W,TC=100	50139	BCK1820FT
A3R140	322-3085-07			RES,FXD:METAL FILM;75 OHM,0.1%,0.2W,TC=25 PPM	91637	CCF502-C75ROOBT
A3R141	321-5017-00			RES,FXD:THICK FILM;825 OHM,1%,0.125W,TC=100	50139	BCK8250FT
A3R142	321-5113-00			RES,FXD:THICK FILM;75 OHM,1%,0.125W,TC=100 PPM	56845	CRCW1206-75ROFT
A3R143	311-5033-00			RES,VAR,TRMR:CERMET;500 OHM,25%,0.25W,4MM SQ, TOP	TK2073	G4DT501M
A3R144	321-5018-00			RES,FXD:THICK FILM;1.0K OHM,1%,0.125W,TC=100 PPM	50139	BCK1001FT
A3R146	321-5012-00			RES,FXD:THICK FILM;332 OHM,1%,0.125W,TC=100	50139	BCK3320FT
A3R147	321-5014-00			RES,FXD:THICK FILM;475 OHM,1%,0.125W,TC=100	50139	BCK4750FT
A3R148	321-5012-00			RES,FXD:THICK FILM;332 OHM,1%,0.125W,TC=100	50139	BCK3320FT
A3R149	321-5014-00			RES,FXD:THICK FILM;475 OHM,1%,0.125W,TC=100	50139	BCK4750FT
A3R151	321-5022-00			RES,FXD:THICK FILM;2.21K OHM,1%,0.125W,TC=100 PPM	50139	BCK2211FT
A3R152	321-5026-00			RES,FXD:THICK FILM;4.75K OHM,1%,0.125W,TC=100 PPM	50139	BCK4751FT
A3R153	321-5266-00			RES,FXD:THICK FILM;11K OHM,1%,0.125W,TC=100	59124	RK73H2B1102FT
A3R154	321-5113-00			RES,FXD:THICK FILM;75 OHM,1%,0.125W,TC=100 PPM	56845	CRCW1206-75ROFT
A3R155	321-5028-00			RES,FXD:THICK FILM;6.81K OHM,1%,0.125W,TC=100 PPM	50139	BCK6811FT
A3R157	321-5012-00			RES,FXD:THICK FILM;332 OHM,1%,0.125W,TC=100	50139	BCK3320FT
A3R158	322-3085-07			RES,FXD:METAL FILM;75 OHM,0.1%,0.2W,TC=25 PPM	91637	CCF502-C75ROOBT
A3R159	321-5017-00			RES,FXD:THICK FILM;825 OHM,1%,0.125W,TC=100	50139	BCK8250FT
A3R160	321-5113-00			RES,FXD:THICK FILM;75 OHM,1%,0.125W,TC=100 PPM	56845	CRCW1206-75ROFT
A3R161	311-5033-00			RES,VAR,TRMR:CERMET;500 OHM,25%,0.25W,4MM SQ, TOP	TK2073	G4DT501M
A3R162	321-5018-00			RES,FXD:THICK FILM;1.0K OHM,1%,0.125W,TC=100 PPM	50139	BCK1001FT
A3R165	321-5022-00			RES,FXD:THICK FILM;2.21K OHM,1%,0.125W,TC=100 PPM	50139	BCK2211FT
A3R166	321-5026-00			RES,FXD:THICK FILM;4.75K OHM,1%,0.125W,TC=100 PPM	50139	BCK4751FT
A3R167	321-5266-00			RES,FXD:THICK FILM;11K OHM,1%,0.125W,TC=100	59124	RK73H2B1102FT
A3R168	321-5113-00			RES,FXD:THICK FILM;75 OHM,1%,0.125W,TC=100 PPM	56845	CRCW1206-75ROFT
A3R169	321-5028-00			RES,FXD:THICK FILM;6.81K OHM,1%,0.125W,TC=100 PPM	50139	BCK6811FT
A3R170	321-5012-00			RES,FXD:THICK FILM;332 OHM,1%,0.125W,TC=100	50139	BCK3320FT
A3R171	321-5014-00			RES,FXD:THICK FILM;475 OHM,1%,0.125W,TC=100	50139	BCK4750FT
A3R172	321-5012-00			RES,FXD:THICK FILM;332 OHM,1%,0.125W,TC=100	50139	BCK3320FT

Replaceable electrical parts list (Cont.)

Component number	Tektronix part number	Serial no. effective	Serial no. discont'd	Name & description	Mfr. code	Mfr. part number
A3R174	321-5012-00			RES,FXD:THICK FILM;332 OHM,1%,0.125W,TC=100	50139	BCK3320FT
A3R175	321-5018-00			RES,FXD:THICK FILM;1.0K OHM,1%,0.125W,TC=100 PPM	50139	BCK1001FT
A3R176	321-5050-00			RES,FXD:THICK FILM;33.2 OHM,1%,0.125W,TC=100 PPM	57668	MCR18FWEA33E2
A3R177	321-5050-00			RES,FXD:THICK FILM;33.2 OHM,1%,0.125W,TC=100 PPM	57668	MCR18FWEA33E2
A3R178	321-5050-00			RES,FXD:THICK FILM;33.2 OHM,1%,0.125W,TC=100 PPM	57668	MCR18FWEA33E2
A3R179	321-5050-00			RES,FXD:THICK FILM;33.2 OHM,1%,0.125W,TC=100 PPM	57668	MCR18FWEA33E2
A3R180	321-5050-00			RES,FXD:THICK FILM;33.2 OHM,1%,0.125W,TC=100 PPM	57668	MCR18FWEA33E2
A3R181	321-5050-00			RES,FXD:THICK FILM;33.2 OHM,1%,0.125W,TC=100 PPM	57668	MCR18FWEA33E2
A3R182	321-5050-00			RES,FXD:THICK FILM;33.2 OHM,1%,0.125W,TC=100 PPM	57668	MCR18FWEA33E2
A3R183	321-5050-00			RES,FXD:THICK FILM;33.2 OHM,1%,0.125W,TC=100 PPM	57668	MCR18FWEA33E2
A3R184	321-5000-00			RES,FXD:THICK FILM;10 OHM,1%,0.125W,TC=100 PPM	59124	RK73H2B10R0FT
A3R185	321-5002-00			RES,FXD:THICK FILM;15 OHM,1%,0.125W,TC=100 PPM	59124	RK73H2B15R0FT
A3R186	321-5000-00			RES,FXD:THICK FILM;10 OHM,1%,0.125W,TC=100 PPM	59124	RK73H2B10R0FT
A3R187	321-5002-00			RES,FXD:THICK FILM;15 OHM,1%,0.125W,TC=100 PPM	59124	RK73H2B15R0FT
A3R190	321-5039-00	671-3123-02		RES,FXD:THICK FILM;56.2K OHM,1%,0.125W,TC=100 PPM	50139	BCK5622FT
A3R191	321-5014-00	671-3123-02		RES,FXD:THICK FILM;475 OHM,1%,0.125W,TC=100 PPM	50139	BCK4750FT
A3R1000	321-5014-00			RES,FXD:THICK FILM;475 OHM,1%,0.125W,TC=100	50139	BCK4750FT
A3R1001	321-5006-00			RES,FXD:THICK FILM;100 OHM,1%,0.125W,TC=100	50139	BCK1000FT
A3R1002	321-5050-00			RES,FXD:THICK FILM;33.2 OHM,1%,0.125W,TC=100 PPM	57668	MCR18FWEA33E2
A3R1003	321-5050-00			RES,FXD:THICK FILM;33.2 OHM,1%,0.125W,TC=100 PPM	57668	MCR18FWEA33E2
A3R1004	321-5038-00			RES,FXD:THICK FILM;47.5K OHM,1%,0.125W,TC=100 PPM	50139	BCK4752FT
A3R1005	321-5024-00			RES,FXD:THICK FILM;3.32K OHM,1%,0.125W,TC=100 PPM	50139	BCK3321FT
A3R1006	321-5010-00			RES,FXD:THICK FILM;221 OHM,1%,0.125W,TC=100	50139	BCK221FT
A3R1007	321-5006-00			RES,FXD:THICK FILM;100 OHM,1%,0.125W,TC=100	50139	BCK1000FT
A3R1008	321-5000-00			RES,FXD:THICK FILM;10 OHM,1%,0.125W,TC=100 PPM	59124	RK73H2B10R0FT
A3R1009	321-5009-00			RES,FXD:THICK FILM;182 OHM,1%,0.125W,TC=100	50139	BCK1820FT
A3R1010	321-5050-00			RES,FXD:THICK FILM;33.2 OHM,1%,0.125W,TC=100 PPM	57668	MCR18FWEA33E2
A3R1011	321-5050-00			RES,FXD:THICK FILM;33.2 OHM,1%,0.125W,TC=100 PPM	57668	MCR18FWEA33E2
A3R1012	321-5050-00			RES,FXD:THICK FILM;33.2 OHM,1%,0.125W,TC=100 PPM	57668	MCR18FWEA33E2
A3R1013	321-5050-00			RES,FXD:THICK FILM;33.2 OHM,1%,0.125W,TC=100 PPM	57668	MCR18FWEA33E2
A3R1014	321-5050-00			RES,FXD:THICK FILM;33.2 OHM,1%,0.125W,TC=100 PPM	57668	MCR18FWEA33E2
A3R1015	321-5050-00			RES,FXD:THICK FILM;33.2 OHM,1%,0.125W,TC=100 PPM	57668	MCR18FWEA33E2
A3R1016	321-5006-00			RES,FXD:THICK FILM;100 OHM,1%,0.125W,TC=100	50139	BCK1000FT
A3R1500	321-5021-00			RES,FXD:THICK FILM;1.82K OHM,1%,0.125W,TC=100 PPM	50139	BCK1821FT
A3R1501	321-5021-00			RES,FXD:THICK FILM;1.82K OHM,1%,0.125W,TC=100 PPM	50139	BCK1821FT
A3R1502	321-5021-00			RES,FXD:THICK FILM;1.82K OHM,1%,0.125W,TC=100 PPM	50139	BCK1821FT
A3T1	120-1933-00			TRANSFORMER,SIG:WIDEBAND;0.02-100MHZ,INSERT	15542	T 1.5-6 X65
A3T2	120-1933-00			TRANSFORMER,SIG:WIDEBAND;0.02-100MHZ,INSERT	15542	T 1.5-6 X65

Replaceable electrical parts list (Cont.)

Component number	Tektronix part number	Serial no. effective	Serial no. discont'd	Name & description	Mfr. code	Mfr. part number
A3T3	120-1959-00		671-3123-01	XFMR,TOROID:AM700 XLR	80009	120195900
A3T3	120-1860-00	671-3123-02		TRANSFORMER,SIG:TOROID,1:1,22UH/WINDING,Z-93145B	0JR03	Z-93145B
A3T4	120-1959-00		671-3123-01	XFMR,TOROID:AM700 XLR	80009	120195900
A3T4	120-1860-00	671-3123-02		TRANSFORMER,SIG:TOROID,1:1,22UH/WINDING,Z-93145B,VE RT MOUNT	0JR03	Z-93145B
A3TP1	214-4085-00			TERM,TEST POINT:0.070 ID,0.220 H,0.063 DIAP CB,0.015 X 0.032 BRASS,W/RED NYLON COLLAR	26364	104-01-02
A3TP2	214-4085-00			TERM,TEST POINT:0.070 ID,0.220 H,0.063 DIAP CB,0.015 X 0.032 BRASS,W/RED NYLON COLLAR	26364	104-01-02
A3TP3	214-4085-00			TERM,TEST POINT:0.070 ID,0.220 H,0.063 DIAP CB,0.015 X 0.032 BRASS,W/RED NYLON COLLAR	26364	104-01-02
A3TP4	214-4085-00			TERM,TEST POINT:0.070 ID,0.220 H,0.063 DIAP CB,0.015 X 0.032 BRASS,W/RED NYLON COLLAR	26364	104-01-02
A3U1	156-5324-01			IC,DIGITAL:ECL,TRANSLATOR;QUAD ECL-TO-TTL	04713	MC10H125FN2
A3U6	156-6059-01			IC,MISC:CMOS,ANALOG SWITCH;QUAD	1ES66	DG444DY-T
A3U8	156-6735-01			IC,LINEAR:BIPOLAR,OP-AMP;CURRENT FEEDBACK,65MHZ,W/ DISABLE,1 TO 10 GAIN RANGE	24355	AD810AR-REEL
A3U9	156-6735-01			IC,LINEAR:BIPOLAR,OP-AMP;CURRENT FEEDBACK,65MHZ,W/ DISABLE,1 TO 10 GAIN RANGE	24355	AD810AR-REEL
A3U10	234-1119-20			IC,ASIC:BIPOLAR,SYNC SEPERATOR (CORE);QC6-120, M652-019	TK2598	234111920
A3U11	156-6921-00			IC,MISC:BIPOLAR,VIDEO SUBSYSTEM;NTSC/PAL CHROMA SUBCARRIER LOCK/REGENERATION CONTROLLER	07933	RC6120QB
A3U12	156-5138-01			IC,LINEAR:BIFET,OP-AMP;DUAL	01295	TL072CDR
A3U13	156-5138-01			IC,LINEAR:BIFET,OP-AMP;DUAL	01295	TL072CDR
A3U14	156-5297-01			IC,LINEAR:BIPOLAR,VOLTAGE REGULATOR,ADJUSTABLE,SHUNT,100MA,2%,TL431CD,SO8.150,12MM T&R	01295	TL431CDR
A3U15	156-5297-01			IC,LINEAR:BIPOLAR,VOLTAGE REGULATOR,ADJUSTABLE,SHUNT,100MA,2%,TL431CD,SO8.150,12MM T&R	01295	TL431CDR
A3U16	156-6032-01			IC,MISC:TTL,INTERFACE;DUAL DIFFERENTIAL LINE DRIVER,MEETS RS-422A STANDARD	01295	UA9638CDR
A3U18	156-6228-01			IC,DIGITAL:HCMOS,RGTR:8-BIT PISO SHIFT RGTR	01295	SN74HC166DR
A3U19	156-6228-01			IC,DIGITAL:HCMOS,RGTR:8-BIT PISO SHIFT RGTR	01295	SN74HC166DR
A3U22	156-6274-01			IC,MEMORY:CMOS,SRAM;32K X 8,25NS	80009	156627401
A3U23	156-6274-01			IC,MEMORY:CMOS,SRAM;32K X 8,25NS	80009	156627401
A3U24	163-0292-00			IC,DGTL:CMOS,PLD;EPLD,7128E,128 M/C,64I/O,4 IN,15NS	80009	163-0292-00
A3U25	156-5514-00			IC,DIGITAL:FTTL,FLIP FLOP;OCTAL D-TYPE, WITH ENABLE	01295	SN74F377ADW
A3U26	156-5052-01			IC,DIGITAL:FTTL,GATE;HEX INV	01295	SN74F04DR
A3U27	156-5147-01			IC,DIGITAL:HCTCMOS,FLIP FLOP;OCTAL D-TYPE,CLEAR	01295	SN74HCT273DWR
A3U28	156-5147-01			IC,DIGITAL:HCTCMOS,FLIP FLOP;OCTAL D-TYPE,CLEAR	01295	SN74HCT273DWR
A3U29	156-5147-01			IC,DIGITAL:HCTCMOS,FLIP FLOP;OCTAL D-TYPE,CLEAR	01295	SN74HCT273DWR
A3U30	156-5147-01			IC,DIGITAL:HCTCMOS,FLIP FLOP;OCTAL D-TYPE,CLEAR	01295	SN74HCT273DWR

Replaceable electrical parts list (Cont.)

Component number	Tektronix part number	Serial no. effective	Serial no. discont'd	Name & description	Mfr. code	Mfr. part number
A3U31	160-9920-00			IC,DGTL:CMOS,PLD;EEPROM,7128E,128 M/C,64I/O,4 IN,15NS	80009	160-9920-00
A3U32	156-6561-00			IC,CONVERTER:BIPOLAR,D/A:10 BIT,60MHZ,CURRENT OUT	61271	MB40760PF
A3U34	156-6735-01			IC,LINEAR:BIPOLAR,OP-AMP;CURRENT FEEDBACK,65MHZ	24355	AD810AR-REEL
A3U35	156-6643-00			IC,LINEAR:BIPOLAR,OP-AMP;50MHZ,UNITYGAIN STABLE	24355	AD847JR
A3U36	160-9926-00			IC,MEMORY:CMOS,EPROM;256K X 8,150NS	80009	160992600
A3U37	163-0291-00			IC,MEMORY:CMOS,EPROM;256K X 8,150NS	80009	163029100
A3U38	160-9924-00			IC,MEMORY:CMOS,EPROM;128K X8,120NS,OTP	80009	160992400
	136-5011-00	671-3123-00	671-3123-00	SOCKET,PLCC:SMD;32 POS,0.05 CTR,0.800X 0.700 INCH WIDE,0.200 H,BE/CU,TIN,W/O PLZ POSTS	22526	69802-132
A3U39	160-9925-00			IC,MEM:CMOS,32768 X 8 EPROM,120NS,OTP;27C256, PLCC32	80009	160992500
	136-5011-00	671-3123-00	671-3123-00	SOCKET,PLCC:SMD;32 POS,0.05 CTR,0.800X 0.700 INCH WIDE,0.200 H,BE/CU,TIN,W/O PLZ POSTS	22526	69802-132
A3U40	160-9923-00			IC,MEMORY:CMOS,32768 X 8 EPROM,120NS,OTP;27C256, PLCC32	80009	160992300
A3U41	156-5147-01			IC,DIGITAL:HCTCMOS,FLIP FLOP;OCTAL D-TYPE,CLEAR	01295	SN74HCT273DWR
A3U42	156-5147-01			IC,DIGITAL:HCTCMOS,FLIP FLOP;OCTAL D-TYPE,CLEAR	01295	SN74HCT273DWR
A3U43	156-5147-01			IC,DIGITAL:HCTCMOS,FLIP FLOP;OCTAL D-TYPE,CLEAR	01295	SN74HCT273DWR
A3U44	156-5147-01			IC,DIGITAL:HCTCMOS,FLIP FLOP;OCTAL D-TYPE,CLEAR	01295	SN74HCT273DWR
A3U45	160-9920-00			IC,DGTL:CMOS,PLD;EEPROM,7128E,128 M/C,64I/O,4 IN,15NS	80009	160-9920-00
A3U46	156-5514-00			IC,DIGITAL:FTTL,FLIP FLOP;OCTAL D-TYPE, WITH ENABLE	01295	SN74F377ADW
A3U47	156-6561-00			IC,CONVERTER:BIPOLAR,D/A:10 BIT,60MHZ,CURRENT OUT	61271	MB40760PF
A3U49	156-5052-01			IC,DIGITAL:FTTL,GATE;HEX INV	01295	SN74F04DR
A3U50	156-6735-01			IC,LINEAR:BIPOLAR,OP-AMP;CURRENT FEEDBACK,65MHZ	24355	AD810AR-REEL
A3U51	156-6643-00			IC,LINEAR:BIPOLAR,OP-AMP;50MHZ,UNITYGAIN STABLE	24355	AD847JR
A3U52	163-0291-00			IC,MEMORY:CMOS,EPROM;256K X 8,150NS	80009	163029100
A3U53	160-9926-00			IC,MEMORY:CMOS,EPROM;256K X 8,150NS	80009	160992600
A3U54	160-9924-00			IC,MEMORY:CMOS,EPROM;128K X8,120NS,OTP	80009	160992400
A3U55	160-9925-00			IC,MEMORY:CMOS,32768 X 8 EPROM,120NS,027C256	80009	160992500
A3U56	160-9923-00			IC,MEMORY:CMOS,32768 X 8 EPROM,120NS,OT,27C256,	80009	160992300
A3U57	156-5070-01			IC,DIGITAL:HCTCMOS,BFR;OCTAL BFR/DRIVER, 3-STATE	OJR04	TC74HCT244AFW(E
A3U58	156-5070-01			IC,DIGITAL:HCTCMOS,BFR;OCTAL BFR/DRIVER, 3-STATE	OJR04	TC74HCT244AFW(E
A3U59	156-5131-01			IC,DIGITAL:HCTCMOS,GATE;HEX INV SCHMITT TRIG	04713	MC74HCT14ADR2
A3U60	156-5324-01	671-3123-01		IC,DIGITAL:ECL,TRANSLATOR;QUAD ECL-TO-TTL	04713	MC10H125FNR2

Replaceable electrical parts list

Component number	Tektronix part number	Serial no. effective	Serial no. discont'd	Name & description	Mfr. code	Mfr. part number
A4	671-3242-00		B020515	CKT BD ASSY:POWER SUPPLY BOARD	80009	671324200
A4	671-3242-01	B020516	B020829	CKT BD ASSY:POWER SUPPLY BOARD	80009	671324201
A4	671-3242-02	B020830	B021139	CKT BD ASSY:POWER SUPPLY BOARD	80009	671324202
A4	671-3242-03	B020830	B021139	CKT BD ASSY:POWER SUPPLY BOARD	80009	671324203
A4	671-3242-04	B021140	B021954	CKT BD ASSY:POWER SUPPLY BOARD	80009	671324204
A4	671-3242-05	B021955	B022882	CKT BD ASSY:POWER SUPPLY BOARD	80009	671324205
A4	671-3242-06	B022883		CKT BD ASSY:POWER SUPPLY BOARD	80009	671324206
A4C5	285-1246-00			CAP,FXD,PPR DI:0.022UF,20%,250VAC	TK0515	PME 289 MB 5220
A4C6	285-1246-00			CAP,FXD,PPR DI:0.022UF,20%,250VAC	TK0515	PME 289 MB 5220
A4C105	281-0826-00			CAP,FXD,CER:MLC;2200PF,10%,100V,0.100 X	TK1743	CGB222KEX
A4C120	281-0775-01			CAP,FXD,CER:MCL;0.1UF,20%,50V,Z5U,0.170	04222	SA75E104MAA
A4C130	281-0812-00			CAP,FXD,CER:MLC;1000PF,10%,100V,0.100 X	04222	SA71C102KAA
A4C135	281-0788-00	671-3242-01		CAP,FXD,CER:MLC;470PF,10%,100V,0.100 X 0.170	04222	SA72C471KAA
A4C142	290-1301-00			CAP,FXD,ALUM:2700UF,20%,10V,12.5 X 30MM (0.492 X 1.180)	0H1N5	CEEFM1A272M7
A4C143	290-1301-00			CAP,FXD,ALUM:2700UF,20%,10V,12.5 X 30MM (0.492 X 1.180)	0H1N5	CEEFM1A272M7
A4C144	290-1301-00			CAP,FXD,ALUM:2700UF,20%,10V,12.5 X 30MM (0.492 X 1.180)	0H1N5	CEEFM1A272M7
A4C145	281-0775-01			CAP,FXD,CER:MCL;0.1UF,20%,50V,Z5U,0.170	04222	SA75E104MAA
A4C150	290-1302-00			CAP,FXD,ALUM:1000UF,20%,35V,12.5 X 30MM (0.492 X 1.180)	0H1N5	CEEFM1V102M7
A4C151	281-0812-00			CAP,FXD,CER:MLC;1000PF,10%,100V,0.100 X	04222	SA71C102KAA
A4C152	290-1302-00			CAP,FXD,ALUM:1000UF,20%,35V,12.5 X 30MM (0.492 X 1.180)	0H1N5	CEEFM1V102M7
A4C160	290-1315-00			CAP,FXD,ALUM:47UF,20%,35V,ESR=0.34 OHM(100KHZ,20C),6X11MM,LOW IMP	55680	UPL1V470MEH1TD
A4C162	290-1315-00			CAP,FXD,ALUM:47UF,20%,35V,ESR=0.34 OHM(100KHZ,20C),6X11MM,LOW IMP	55680	UPL1V470MEH1TD
A4C170	290-1315-00			CAP,FXD,ALUM:47UF,20%,35V,ESR=0.34 OHM(100KHZ,20C),6X11MM,LOW IMP	55680	UPL1V470MEH1TD
A4C172	290-1315-00			CAP,FXD,ALUM:47UF,20%,35V,ESR=0.34 OHM(100KHZ,20C),6X11MM,LOW IMP	55680	UPL1V470MEH1TD
A4C180	281-0775-01			CAP,FXD,CER:MCL;0.1UF,20%,50V,Z5U,0.170	04222	SA75E104MAA
A4C182	281-0775-01			CAP,FXD,CER:MCL;0.1UF,20%,50V,Z5U,0.170	04222	SA75E104MAA
A4C200	281-0775-01			CAP,FXD,CER:MCL;0.1UF,20%,50V,Z5U,0.170	04222	SA75E104MAA
A4C220	281-0563-00			CAP,FXD,CER:MLC;0.47UF,20%,50V,0.150 X0.290	04222	SA305E474MAA
A4C222	281-0812-00			CAP,FXD,CER:MLC;1000PF,10%,100V,0.100 X	04222	SA71C102KAA
A4C225	290-1301-00			CAP,FXD,ALUM:2700UF,20%,10V,12.5 X 30MM (0.492 X 1.180)	0H1N5	CEEFM1A272M7
A4C230	281-0563-00			CAP,FXD,CER:MLC;0.47UF,20%,50V,0.150 X0.290	04222	SA305E474MAA

Replaceable electrical parts list (Cont.)

Component number	Tektronix part number	Serial no. effective	Serial no. discont'd	Name & description	Mfr. code	Mfr. part number
A4C253	290-1301-00			CAP,FXD,ALUM:2700UF,20%,10V,12.5 X 30MM (0.492 X 1.180)	0H1N5	CEEFM1A272M7
A4C254	290-1301-00			CAP,FXD,ALUM:2700UF,20%,10V,12.5 X 30MM (0.492 X 1.180)	0H1N5	CEEFM1A272M7
A4C320	281-0775-01		671-3242-00	CAP,FXD,CER:MCL:0.1UF,20%,50V,Z5U,0.170	04222	SA105E104MAA
A4C320	290-1315-00	671-3242-01	671-3242-02	CAP,FXD,ALUM:47UF,20%,35V,ESR=0.34 OHM(100KHZ,20C),6X11MM,LOW IMP	55680	UPL1V470MEH1TD
A4C320	290-0766-00	671-3242-03		CAP,FXD,ALUM:2.2UF,+50-20%,160V,8 X 11.5MM,RADIAL	61058	ECEA2CS2R2
A4C325	290-1301-00			CAP,FXD,ALUM:2700UF,20%,10V,12.5 X 30MM (0.492 X 1.180)	0H1N5	CEEFM1A272M7
A4C350	281-0775-01			CAP,FXD,CER:MCL:0.1UF,20%,50V,Z5U,0.170	04222	SA105E104MAA
A4C358	290-1301-00			CAP,FXD,ALUM:2700UF,20%,10V,12.5 X 30MM (0.492 X 1.180)	0H1N5	CEEFM1A272M7
A4C360	290-1301-00			CAP,FXD,ALUM:2700UF,20%,10V,12.5 X 30MM (0.492 X 1.180)	0H1N5	CEEFM1A272M7
A4C365	290-1315-00			CAP,FXD,ALUM:47UF,20%,35V,ESR=0.34 OHM(100MHZ,20C),6X11MM,LOW IMP	55680	UPL1V470MEH1TD
A4C370	290-1301-00			CAP,FXD,ALUM:2700UF,20%,10V,12.5 X 30MM (0.492 X 1.180)	0H1N5	CEEFM1A272M7
A4C415	281-0775-01		671-3242-00	CAP,FXD,CER:MCL:0.1UF,20%,50V,Z5U,0.170	04222	SA105E104MAA
A4C415	281-0813-00	671-3242-01	671-3242-02	CAP,FXD,CERAMIC:MLC,0.047UF,20%,50V,0.100 X 0.170,AXIAL,MI	04222	SA105E473MAA
A4C415	283-0051-02	671-3242-03		CAP,FXD,CER DI:0.0033UF,5%,100V,SQUARE,MI	24165	1C20COG332J100R
A4C464	290-1301-00			CAP,FXD,ALUM:2700UF,20%,10V,12.5 X 30MM (0.492 X 1.180)	0H1N5	CEEFM1A272M7
A4C475	290-1301-00			CAP,FXD,ALUM:2700UF,20%,10V,12.5 X 30MM (0.492 X 1.180)	0H1N5	CEEFM1A272M7
A4C480	290-1301-00			CAP,FXD,ALUM:2700UF,20%,10V,12.5 X 30MM (0.492 X 1.180)	0H1N5	CEEFM1A272M7
A4C481	290-1301-00			CAP,FXD,ALUM:2700UF,20%,10V,12.5 X 30MM (0.492 X 1.180)	0H1N5	CEEFM1A272M7
A4C500	285-1329-00			CAP,FXD,PLASTIC:METALIZED FILM:680PF,10%,1600V,POLY-PROPYLENE,.70X.43	TK1913	FKP1 680/1600/1
A4C521	281-0791-00			CAP,FXD,CER:MLC:270PF,10%,100V,0.100 X 0.170	04222	SA72C271KAA
A4C575	281-0812-00			CAP,FXD,CER:MLC:1000PF,10%,100V,0.100 X	04222	SA71C102KAA
A4C621	281-0772-00			CAP,FXD,CER:MLC:4700PF,10%,100V,0.100 X	04222	SA71C472KAA
A4C650	281-0563-00			CAP,FXD,CER:MLC:0.47UF,20%,50V,0.150 X 0.290	04222	SA305E474MAA
A4C656	290-1309-00			CAP,FXD,AL:100UF,20%,63V,10 X 20MM,RADIAL,105 DEG,LOW Z,T&A	0H1N5	CEEFM1J101M6-T4
A4C657	281-0775-01			CAP,FXD,CER:MCL:0.1UF,20%,50V,Z5U,0.170	04222	SA75E104MAA
A4C700	285-1421-00			CAP,FXD,PLASTIC:1.0UF,10%,400V,	TK1913	MKS4 1.0/400/10
A4C717	281-0563-00			CAP,FXD,CER:MLC:0.47UF,20%,50V,0.150 X 0.290	04222	SA305E474MAA
A4C722	281-0788-00			CAP,FXD,CER:MLC:470PF,10%,100V,0.100 X 0.170	04222	SA72C471KAA

Replaceable electrical parts list (Cont.)

Component number	Tektronix part number	Serial no. effective	Serial no. discont'd	Name & description	Mfr. code	Mfr. part number
A4C727	281-0775-01			CAP,FXD,CER:MCL;0.1UF,20%,50V,Z5U,0.170	04222	SA75E104MAA
A4C820	285-1252-00			CAP,FXD,PLASTIC:0.15UF,10%,250VAC	D5243	F1772-415-2000
A4C845	290-1293-00			CAP,FXD,ALUM:390UF,20%,200V,ESR=0.425 OHM(120HZ,20C),25X30MM,105C	0H1N5	CEAUF2D391M20
A4C865	290-1293-00			CAP,FXD,ALUM:390UF,20%,200V,ESR=0.425 OHM(120HZ,20C),25X30MM,105C	0H1N5	CEAUF2D391M20
A4C942	281-0812-00			CAP,FXD,CER:MLC;1000PF,10%,100V,0.100 X	04222	SA71C102KAA
A4CR150	152-0670-00		671-3242-00	DIODE,RECT:SCHTKY;40V,3A,IFSM=80A,VF=525MV	04713	1N5822
A4CR150	152-0581-00	671-3242-01		DIODE,RECT:SCHTKY,20V,1A,,450VF,25A IFSM,1N5817	04713	1N5817
A4CR160	152-0670-00		671-3242-00	DIODE,RECT:SCHTKY;40V,3A,IFSM=80A,VF=525MV	04713	1N5822
A4CR160	152-0581-00	671-3242-01		DIODE,RECT:SCHTKY,20V,1A,,450VF,25A IFSM,1N5817	04713	1N5817
A4CR170	152-0601-01			DIODE,RECT:ULTRA FAST;150V,25NS,35A IFSM	04713	MUR115RL
A4CR180	152-0601-01			DIODE,RECT:ULTRA FAST;150V,25NS,35A IFSM	04713	MUR115RL
A4CR200	152-0141-02	671-3242-01		DIODE,SIG:ULTRA FAST,40V,150MA,4NS,2PF,1N4152,DO-35	01295	1N4152R
A4CR320	152-0884-00			DIODE,RECT:SCHTKY;35V,16A,150A IFSM,630MVF	04713	MBR1635
A4CR500	152-1085-00			DIODE,RECT:ULTRA FAST;1000V,1A,30A IFSM,75 NS SOFT RECOVERY	0LUA3	BYV26E
A4CR575	152-0884-00			DIODE,RECT:SCHTKY;35V,16A,150A IFSM,630MVF	04713	MBR1635
	214-2953-00	671-3242-01		HEAT SINK,SEMIC:TRANSISTOR,TO-220,VERTICAL MOUNT	13103	6030B-TT
	211-0012-00	671-3242-01		SCREW,MACHINE:4-40 X 0.375,PNH,STL CD PL,POZ	93907	ORDER BY DESC
A4CR600	152-0601-01			DIODE,RECT:ULTRA FAST;150V,25NS,35A IFSM	04713	MUR115RL
A4CR648	152-0601-01		671-3242-00	DIODE,RECT:ULTRA FAST;150V,25NS,35A IFSM	04713	MUR115RL
A4CR648	152-0581-00	671-3242-01		DIODE,RECT:SCHTKY,20V,1A,,450VF,25A IFSM,1N5817	04713	1N5817
A4CR649	152-0601-01		671-3242-00	DIODE,RECT:ULTRA FAST;150V,25NS,35A IFSM,MUR120,T&R	12969	UES1103
A4CR649	152-0581-00	671-3242-01		DIODE,RECT:SCHTKY,20V,1A,,450VF,25A IFSM,1N5817	04713	1N5817
A4CR820	152-0750-00			DIODE,RECT:FAST RCVRY;BRIDGE,600V,3A, IFSM=125A,250NS	TK2319	RKBPC606
A4DS720	150-0050-00			LAMP,GLOW:135V MAX,1.9MA,C2A-T,WIRE LEAD	0J9R2	NE-2Q-11R-T
A4E820	119-0181-00			ARSR,ELEC SURGE:230V, +/-15%; GAS DISCHARGE	0C8T6	BBS-230V +/-15%
A4F940	159-0023-00			FUSE,CARTRIDGE:3AG,2A,250V,SLOW BLOW, (FOR 90-132VAC OPERATION)	71400	MDX2
A4F940	159-0019-00			FUSE,CARTRIDGE:3AG,1A,250V,SLOW BLOW, (FOR 180-250VAC OPERATION)	71400	MDL 1
	204-0906-00			BODY,FUSEHOLDER:3AG & 5 X 20MM FUSES	61935	TYPE FAU 031.35
A4FL950	119-3835-00			FILTER,RFI:3A,250V,400HZ W/PC TERMINALS	0GV52	FN 326-3/02
A4J160	131-3364-00			CONN,HDR:PCB;MALE,STR,2 X 17,0.1 CTR,0.365D	53387	2534-6002UB
A4J370	131-4917-00		671-3242-00	CONN,HDR:PCB;MALE,STR,1 X 2,0.1 CTR,0.235 MLG X 0.110 TAIL,30GOLD,TUBE,HIGH TEMP	00779	104714-3
A4J370	131-3270-00	671-3242-01		CONN,HDR:PCB,MALE,STR,1 X 2,0.1 CTR,0.295 MLG X 0.140 TAIL,TIN,PLZ WALL,W/FRICTION LOCK,	00779	640456-2
A4H5	214-2953-00	671-3242-01		HEAT SINK,SEMIC:TRANSISTOR,TO-220,VERTICAL MOUNT	13103	6030B-TT

Replaceable electrical parts list (Cont.)

Component number	Tektronix part number	Serial no. effective	Serial no. discont'd	Name & description	Mfr. code	Mfr. part number
A4H6	214-2953-00	671-3242-01		HEAT SINK,SEMIC:TRANSISTOR,TO-220,VERTICAL MOUNT	13103	6030B-TT
A4L150	108-1262-00			INDUCTOR,FXD:POWER:100UH,10%,I<0.75A,RDC<0.23 OHM,Q>15,SRF>5.4MHZ,BOBBIN CORE	TK2058	TSL0807-101KR75
A4L162	108-1262-00			INDUCTOR,FXD:POWER:100UH,10%,I<0.75A,RDC<0.23 OHM,Q>15,SRF>5.4MHZ,BOBBIN CORE	TK2058	TSL0807-101KR75
A4L230	108-0554-00			INDUCTOR,FXD:CUSTOM,POWER:5UH,20%,I<10 A,RDC<0.01 OHM,ROD CORE 276-0147-00	OJR03	108-0554-00
A4L258	108-0554-00			INDUCTOR,FXD:CUSTOM,POWER:5UH,20%,I<10 A,RDC<0.01 OHM,ROD CORE 276-0147-00	OJR03	108-0554-00
A4L656	108-1263-00			INDUCTOR,FXD:POWER:10UH,10%,I<2.1A,RDC<0.043 OHM,Q>20,SRF>19MHZ,BOBBIN	TK2058	TSL0707-100K1R9
A4L700	120-1449-00			TRANSFORMER,RF:COMMON MODE,2.7MH,2A	02113	P104
A4Q100	151-0188-00			XSTR,SIG:BIPOLAR,PNP;40V,200MA,250MHZ,AMPLIFIER	OJR04	2N3906
A4Q127	151-0528-00			THYRISTOR,PWR:BIPOLAR,SCR:50V,16A RMS,PHASE	04713	2N6400
A4Q250	151-1171-00			XSTR,PWR:MOS,N-CH:50V,12A,0.12 OHM	04713	MTP15N05E
A4Q648	151-1300-00			XSTR,PWR:MOS,N-CH:800V,8.0A,1.2 OHM	66958	STH8N80FI
A4Q717	151-0188-00			XSTR,SIG:BIPOLAR,PNP;40V,200MA,250MHZ,AMPLIFIER	OJR04	2N3906
A4R100	322-3172-00		671-3242-00	RES,FXD,FILM:604 OHM,1%,0.2W,TC=T0MI,SM BODY	91637	CCF501G604ROF
A4R100	322-3171-00	671-3242-01		RES,FXD,FILM:590 OHM,1%,0.2W,TC=T0 MI,SMALL BODY	57668	CRB20 FXE 590E
A4R105	322-3284-00		671-3242-00	RES,FXD,FILM:8.87K OHM,1%,0.2W,TC=T0MI,SM BODY	91637	CCF501G88700F
A4R105	322-3281-00	671-3242-01		RES,FXD,FILM:8.25K OHM,1%,0.2W,TC=T0MI,SM BODY	57668	CRB20 FXE 8K25
A4R110	322-3106-00			RES,FXD,FILM:124 OHM,1%,0.2W,TC=100PPM,SM BODY	91637	CCF502G124ROFT
A4R120	322-3193-00			RES,FXD:METAL FILM:1K OHM,1%,0.2W,TC=100 PPM	91637	CCF501G10000F
A4R121	322-3235-00		671-3242-00	RES,FXD:METAL FILM:2.74K OHM,1%,0.2W,TC=100	91637	CCF501G27400F
A4R121	322-3130-00	671-3242-01		RES,FXD,FILM:221 OHM,1%,0.2W,TC=100 PPM	57668	CRB20T68EFX2210
A4R125	322-3172-00	671-3242-01		RES,FXD,FILM:604 OHM,1%,0.2W,TC=100 PPM	57668	CRB20 FXE 604E
A4R135	322-3066-00		671-3242-00	RES,FXD:METAL FILM:47.5 OHM,1%,0.2W,TC=100 PPM	09969	CCF502G47R50F
A4R135	322-3001-00	671-3242-01		RES,FXD,FILM:10 OHM,1%,0.2W,TC=100 PPM	57668	CRB20T68EFX10R0
A4R140	322-3181-00			RES,FXD,FILM:750 OHM,1%,0.2W,TC=T0MI,SM BODY	91637	CCF501G750ROF
A4R150	322-3385-00		671-3242-00	RES,FXD:METAL FILM:100K OHM,1%,0.2W,TC=100 PPM	91637	CCF501G10002F
A4R150	322-3339-00	671-3242-01		RES,FXD:METAL FILM,33.2K OHM,1%,0.2W,TC=100 PPM	91637	CCF50-3322F-R36
A4R152	322-3289-00			RES,FXD:METAL FILM:10K OHM,1%,0.2W,TC=100 PPM	91637	CCF50G10001F
A4R153	322-3378-00			RES,FXD,FILM:84.5K OHM,1%,0.2W,TC=T0MI,SM BODY	91637	CCF50-2F84501F
A4R215	322-3001-00			RES,FXD:METAL FILM:10 OHM,1%,0.2W,TC=100 PPM	91637	CCF501G10R00F
A4R222	315-0101-00			RES,FXD,FILM:100 OHM,5%,0.25W,,MI	TK1727	SFR25 2322-181-
A4R250	322-3030-00			RES,FXD:METAL FILM:20 OHM,1%,0.2W,TC=100 PPM	91637	CCF50G20R00F
A4R255	322-3289-00			RES,FXD:METAL FILM:10K OHM,1%,0.2W,TC=100 PPM	91637	CCF50G10001F
A4R260	308-0643-00		671-3242-00	RES,FXD,WW:0.1 OHM,10%,2W	05347	CS4 0.1 OHM +-3
A4R260	308-0710-00	671-3242-01		RES,FXD:0.27 OHM,5%,1W MI	75042	BW-20-R2700J
A4R314	322-3224-00		671-3242-00	RES,FXD,FILM:2.1K OHM,1%,0.2W,TC=T0MI,SMALL	91637	CCF50-2F21000F

Replaceable electrical parts list (Cont.)

Component number	Tektronix part number	Serial no. effective	Serial no. discont'd	Name & description	Mfr. code	Mfr. part number
A4R314	322-3291-00	671-3242-01		RES,FXD:METAL FILM;10.5K OHM,1%,0.2W,TC=100 PPM	57668	CRB20 FXE 10K5
A4R315	322-3210-00		671-3242-00	RES,FXD:METAL FILM;1.5K OHM,1%,0.2W,TC=100 PPM	91637	CCF501G15000F
A4R315	322-3235-00	671-3242-01		RES,FXD:METAL FILM;2.74K OHM,1%,0.2W,TC=100	57668	CRB20 FXE 2K74
A4R316	322-3097-00		671-3242-00	RES,FXD:METAL 100 OHM,1%,0.2W,TC=100 PPM	57668	CRB20T68EFX1000
A4R316	322-3201-00	671-3242-01	671-3242-01	RES,FXD:METAL 1.21K OHM,1%,0.2W,TC=100 PPM	57668	CRB20T68EFX1211
A4R316	322-3193-00	671-3242-02	671-3242-04	RES,FXD:METAL FILM;1K OHM,1%,0.2W,TC=100 PPM	57668	CRB20T68EFX1001
A4R316	322-3168-00	671-3242-05		RES,FXD:METAL FILM;549 OHM,1%,0.2W,TC=100 PPM	91637	CCF50-5490F-R36
A4R320	315-0101-00			RES,FXD,FILM:100 OHM,5%,0.25W,,MI	TK1727	SFR25 2322-181-
A4R415	311-2231-00			RES,VAR,TRMR:CERMET;1K OHM,20%,0.5W,0.197 SQ,TOP ADJUST	TK2073	GF06UT2 102 M L
A4R416	322-3289-00		671-3242-00	RES,FXD:METAL FILM,10K OHM,1%,0.2W,TC=100 PPM	57668	CRB20T29EFX1002
A4R416	322-3193-00	671-3242-01		RES,FXD:METAL FILM,1K OHM,1%,0.2W,TC=100 PPM	57668	CRB20T68EFX1001
A4R615	322-3285-00			RES,FXD,FILM:9.09K OHM,1%,0.2W,TC=T0MI,SM BODY	91637	CCF501G90900F
A4R616	322-3258-00			RES,FXD:METAL FILM;4.75K OHM,1%,0.2W,TC=100	56845	CCF50-2-G4751FT
A4R617	322-3289-00			RES,FXD:METAL FILM;10K OHM,1%,0.2W,TC=100 PPM	91637	CCF50G10001F
A4R619	322-3289-00			RES,FXD:METAL FILM;10K OHM,1%,0.2W,TC=100 PPM	91637	CCF50G10001F
A4R620	322-3235-00			RES,FXD:METAL FILM;2.74K OHM,1%,0.2W,TC=100	91637	CCF501G27400F
A4R621	322-3289-00			RES,FXD:METAL FILM;10K OHM,1%,0.2W,TC=100 PPM	91637	CCF50G10001F
A4R622	322-3243-00			RES,FXD:METAL FILM;3.32K OHM,1%,0.2W,TC=100	91637	CCF50-1-G33200F
A4R625	322-3201-00		671-3242-05	RES,FXD:METAL FILM;1.21K OHM,1%,0.2W,TC=100	91637	CCF501G12100F
A4R625	322-3218-00	671-3242-06		RES,FXD:METAL FILM,1.82K OHM,1%,0.2W,TC=100 PPM	57668	CRB20 FXE 1K82
A4R630	308-0679-00		671-3242-05	RES,FXD:0.51 OHM,5%,2W	91637	CPF-2-0R51JT1
A4R630	308-0165-00	671-3242-06		RES,FXD,WW:0.5 OHM,5%,5W	05347	CS7 R500J
A4R656	315-0101-00			RES,FXD,FILM:100 OHM,5%,0.25W,MI	TK1727	SFR25 2322-181-
A4R700	322-3258-00			RES,FXD:METAL FILM;4.75K OHM,1%,0.2W,TC=100	56845	CCF50-2-G4751FT
A4R701	322-3258-00			RES,FXD:METAL FILM;4.75K OHM,1%,0.2W,TC=100	56845	CCF50-2-G4751FT
A4R717	322-3314-00			RES,FXD:METAL FILM;18.2K OHM,1%,0.2W,TC=100	91637	CCF501G18201F
A4R718	322-3393-00		671-3242-03	RES,FXD:METAL FILM;121K OHM,1%,0.2W,TC=100 PPM	91637	CCF501G12102F
A4R718	322-3424-00	671-3242-04		RES,FXD:METAL FILM;255K OHM,1%,0.2W,TC=100 PPM	91637	CCF50-2553F-R36
A4R720	322-3265-00			RES,FXD:METAL FILM;5.62K OHM,1%,0.2W,TC=100	91637	CCF501G56200F
A4R722	322-3289-00			RES,FXD:METAL FILM;10K OHM,1%,0.2W,TC=100 PPM	91637	CCF50G10001F
A4R742	322-3335-00			RES,FXD,FILM:30.1K OHM,1%,0.2W,TC=T0MI,SM BODY	91637	CCF501G30101F
A4R743	322-3393-00			RES,FXD:METAL FILM;121K OHM,1%,0.2W,TC=100 PPM	91637	CCF501G12102F
A4R818	322-3402-00			RES,FXD:METAL FILM;150K OHM,1%,0.2W,TC=100 PPM	91637	CCF50G15002F
A4R819	322-3402-00			RES,FXD:METAL FILM;150K OHM,1%,0.2W,TC=100 PPM	91637	CCF50G15002F
A4R822	301-0106-00			RES,FXD,FILM:10M OHM,5%,0.50W	50139	EB1065
A4R845	301-0474-00			RES,FXD,FILM:470K OHM,5%,0.5W	TK1727	SFR30 2322-182-
A4R865	301-0474-00			RES,FXD,FILM:470K OHM,5%,0.5W	TK1727	SFR30 2322-182-
A4R921	303-0204-00		671-3242-00	RES,FXD,CMPSPN:200K OHM,5%,1W	50139	GB2045

Replaceable Electrical Parts

Replaceable electrical parts list (Cont.)

Component number	Tektronix part number	Serial no. effective	Serial no. discont'd	Name & description	Mfr. code	Mfr. part number
A4R921	303-0154-00	671-3242-01		RES,FXD,CMPSN:150K OHM,5%,1W	24546	FP1 150 K OHM 5%
A4R922	315-0101-00			RES,FXD,FILM:100 OHM,5%,0.25W,,MI	TK1727	SFR25 2322-181-
A4R923	322-3235-00	671-3242-01		RES,FXD:METAL FILM,2.74K OHM,1%,0.2W,TC=100 PPM	57668	CRB20 FXE 2K74
A4R925	322-3222-00	671-3242-01		RES,FXD:METAL FILM,2K OHM,1%,0.2W,TC=100 PPM	57668	CRB20T68EFX2001
A4RT820	307-0746-00			RES,THERMAL:5 OHM,10%,7A/DEG C	15454	SG200-S STRAI
A4S930	260-2443-00			SWITCH,PWR:DPDT;PUSH PUSH ALT ACT,PC PINS,6A 250VAC/1A 100VDC,36A AC SURGE,RIGHT ANG MNT,W/HARD END WIRE BAIL	31918	NE18-00-EE-N-47
A4T1	120-1897-00			XFMR,RF,PWR:SWITCHING,70KHZ,PRI 254V,SEC 100V 0.1A,18V 0.1A,+/-5V8.0A,PKG 1.8 X 1.755,1.275HIGH,UL REG	75498	129-0122-EE
A4T2	120-1889-00			TRANSFORMER,RF:TOROID,1:1,150UH +/-10%,DCR 0.13OHM,2.2A MAX,VERTICALMOUNT,W/HOLDER,0.425 WIDE,1.1 HIGH EACH	OJR03	120-1889-00
A4U150	156-3633-00			IC,LINEAR:BIPOLAR,VR:POS,12V,1A,3%,LOW DROPOUT	27014	LM2940CT-12
A4U152	156-4530-00			IC,LINEAR:BIPOLAR,VR:NEG,-12V,1.0A,2%,LOW DROPOUT	27014	LM2990T-12
A4U200	156-4386-00		671-3242-00	IC,LINEAR:BIPOLAR,SW-REGULATOR CONTROLLER, PWM,CURRENT MODE,SINGLE TOTEM POLE OUTPUT	04713	UC3845BN
A4U200	156-4104-00	671-3242-01		UC3843	04713	UC3843N
A4U370	156-2558-00			IC,LINEAR:BIPOLAR,VR:POS,12V,1.5A,2%	01295	TL780-12CKC
A4U410	156-1631-01			IC,LINEAR:BIPOLAR,VR:ADJUST,SHUNT,100MA,2.2%	01295	TL431CLPM
A4U520	156-0885-00			IC, OPTOCOUPLER:7.5KV ISOL, VCEO 70V, I COLL 100MA, HFE 400; 6 PIN DIP,	04713	CNY17-1
A4U615	156-1225-00			IC,LIN:BIPOLAR,COMPARATOR:DUAL,OPEN COLL,300NS	01295	LM393P
A4U722	156-4236-00			IC,LINEAR:BIPOLAR,SW-REGULATOR CONTROLLER;P WM,CURRENT MODE,SINGLE TOTEM POLE OUTPUT	04713	UC3844BN
A4U723	156-0853-00	671-3242-01		IC,LINEAR:BIPOLAR,OP-AMP,DUAL,SINGLE SUPPLY, LM358N,DIP08.3	01295	LM358P
A4VR120	152-0279-00			DIODE,ZENER:5.1V,5%,0.4W	04713	1N751ARL
A4W390	131-4566-00			BUS,CONDUCTOR:0 OHM,300 SPACING,SM BODYMI,DUMMY RES	91637	FRJ-50
A4W500	131-4566-00			BUS,CONDUCTOR:0 OHM,300 SPACING,SM BODYMI,DUMMY RES	91637	FRJ-50

Replaceable electrical parts list

Component number	Tektronix part number	Serial no. effective	Serial no. discont'd	Name & description	Mfr. code	Mfr. part number
A5	671-3125-00			CKT BD ASSY:BLACK GENERATOR (OPTION 01 ONLY)	80009	671312500
A5C1	290-0963-00			CAP,FXD,ALUM:220UF,+50-20%,25WVDC,10 X12MM	55680	UVX1V221MPA
A5C2	290-0963-00			CAP,FXD,ALUM:220UF,+50-20%,25WVDC,10 X12MM	55680	UVX1V221MPA
A5C3	283-5098-00			CAP,FXD,CER:MLC;0.1UF,+80%-20%,50V,Z5U,1206	04222	12065E104ZAT3A
A5C4	283-5098-00			CAP,FXD,CER:MLC;0.1UF,+80%-20%,50V,Z5U,1206	04222	12065E104ZAT3A
A5C5	283-5098-00			CAP,FXD,CER:MLC;0.1UF,+80%-20%,50V,Z5U,1206	04222	12065E104ZAT3A
A5C6	283-5098-00			CAP,FXD,CER:MLC;0.1UF,+80%-20%,50V,Z5U,1206	04222	12065E104ZAT3A
A5C7	283-5098-00			CAP,FXD,CER:MLC;0.1UF,+80%-20%,50V,Z5U,1206	04222	12065E104ZAT3A
A5C8	283-5098-00			CAP,FXD,CER:MLC;0.1UF,+80%-20%,50V,Z5U,1206	04222	12065E104ZAT3A
A5C9	283-5098-00			CAP,FXD,CER:MLC;0.1UF,+80%-20%,50V,Z5U,1206	04222	12065E104ZAT3A
A5C10	283-5098-00			CAP,FXD,CER:MLC;0.1UF,+80%-20%,50V,Z5U,1206	04222	12065E104ZAT3A
A5C11	283-5098-00			CAP,FXD,CER:MLC;0.1UF,+80%-20%,50V,Z5U,1206	04222	12065E104ZAT3A
A5C12	283-5098-00			CAP,FXD,CER:MLC;0.1UF,+80%-20%,50V,Z5U,1206	04222	12065E104ZAT3A
A5C13	283-5098-00			CAP,FXD,CER:MLC;0.1UF,+80%-20%,50V,Z5U,1206	04222	12065E104ZAT3A
A5C14	283-5098-00			CAP,FXD,CER:MLC;0.1UF,+80%-20%,50V,Z5U,1206	04222	12065E104ZAT3A
A5C15	283-5098-00			CAP,FXD,CER:MLC;0.1UF,+80%-20%,50V,Z5U,1206	04222	12065E104ZAT3A
A5C16	283-5098-00			CAP,FXD,CER:MLC;0.1UF,+80%-20%,50V,Z5U,1206	04222	12065E104ZAT3A
A5C17	283-5098-00			CAP,FXD,CER:MLC;0.1UF,+80%-20%,50V,Z5U,1206	04222	12065E104ZAT3A
A5C23	283-5196-00			CAP,FXD,CER:MLC;47PF,5%,100V,NPO,1206	04222	12061A470JAT1A
A5C24	283-5098-00			CAP,FXD,CER:MLC;0.1UF,+80%-20%,50V,Z5U,1206	04222	12065E104ZAT3A
A5C25	281-5012-00			CAP,VAR,CER:5-40PF,25V,N750+/-500PPM/C,SINGLE TURN, TOP-ADJ	04222	CTZ3S-40C-W5
A5C26	283-5098-00			CAP,FXD,CER:MLC;0.1UF,+80%-20%,50V,Z5U,1206	04222	12065E104ZAT3A
A5C27	283-5098-00			CAP,FXD,CER:MLC;0.1UF,+80%-20%,50V,Z5U,1206	04222	12065E104ZAT3A
A5C28	283-5098-00			CAP,FXD,CER:MLC;0.1UF,+80%-20%,50V,Z5U,1206	04222	12065E104ZAT3A
A5C29	283-5098-00			CAP,FXD,CER:MLC;0.1UF,+80%-20%,50V,Z5U,1206	04222	12065E104ZAT3A
A5C30	283-5098-00			CAP,FXD,CER:MLC;0.1UF,+80%-20%,50V,Z5U,1206	04222	12065E104ZAT3A
A5C31	283-5006-00			CAP,FXD,CER:MLC;5PF,+/-0.25PF,50V,NPO,1206	TK2058	C3216C0G1H050C-
A5C32	283-5187-00			CAP,FXD,CER:MLC;15PF,5%,100V,NPO,1206	04222	12061A150JAT1A
A5C33	283-5108-00			CAP,FXD,CER:MLC;68PF,5%,100V,NPO,1206	04222	12061A680JAT1A
A5C34	283-5185-00			CAP,FXD,CER:MLC;1000PF,5%,50V,NPO,1206	04222	12065A72JAT1A
A5C35	283-5189-00			CAP,FXD,CER:MLC;220PF,5%,100V,NPO,1206	04222	12061A221JAT1A
A5C37	283-5197-00			CAP,FXD,CER:MLC;330PF,5%,100V,NPO,1206	04222	12061A331JAT1A
A5C38	283-5238-00			CAP,FXD,CER:MLC;150PF,5%,100V,NPO,1206	04222	12061A151JAT1A
A5C39	283-5197-00			CAP,FXD,CER:MLC;330PF,5%,100V,NPO,1206	04222	12061A331JAT1A
A5C40	283-5188-00			CAP,FXD,CER:MLC;100PF,5%,100V,NPO,1206	04222	12061A71JAT1A
A5C41	283-5238-00			CAP,FXD,CER:MLC;150PF,5%,100V,NPO,1206	04222	12061A151JAT1A
A5C42	283-5196-00			CAP,FXD,CER:MLC;47PF,5%,100V,NPO,1206	04222	12061A470JAT1A

Replaceable electrical parts list (Cont.)

Component number	Tektronix part number	Serial no. effective	Serial no. discont'd	Name & description	Mfr. code	Mfr. part number
A5C43	283-5098-00			CAP,FXD,CER:MLC;0.1UF,+80%-20%,50V,Z5U,1206	04222	12065E104ZAT3A
A5C44	281-5012-00			CAP,VAR,CER:5-40PF,25V,N750+/-500PPM/C,SINGLE TURN, TOP-ADJ	04222	CTZ3S-40C-W5
A5C45	283-5098-00			CAP,FXD,CER:MLC;0.1UF,+80%-20%,50V,Z5U,1206	04222	12065E104ZAT3A
A5C46	283-5098-00			CAP,FXD,CER:MLC;0.1UF,+80%-20%,50V,Z5U,1206	04222	12065E104ZAT3A
A5C47	283-5098-00			CAP,FXD,CER:MLC;0.1UF,+80%-20%,50V,Z5U,1206	04222	12065E104ZAT3A
A5C48	283-5098-00			CAP,FXD,CER:MLC;0.1UF,+80%-20%,50V,Z5U,1206	04222	12065E104ZAT3A
A5C49	283-5098-00			CAP,FXD,CER:MLC;0.1UF,+80%-20%,50V,Z5U,1206	04222	12065E104ZAT3A
A5C50	283-5006-00			CAP,FXD,CER:MLC;5PF,+/-0.25PF,50V,NPO,1206	TK2058	C3216C0G1H050C-
A5C51	283-5187-00			CAP,FXD,CER:MLC;15PF,5%,100V,NPO,1206	04222	12061A150JAT1A
A5C52	283-5108-00			CAP,FXD,CER:MLC;68PF,5%,100V,NPO,1206	04222	12061A680JAT1A
A5C53	283-5185-00			CAP,FXD,CER:MLC;1000PF,5%,50V,NPO,1206	04222	12065A72JAT1A
A5C54	283-5189-00			CAP,FXD,CER:MLC;220PF,5%,100V,NPO,1206	04222	12061A221JAT1A
A5C56	283-5197-00			CAP,FXD,CER:MLC;330PF,5%,100V,NPO,1206	04222	12061A331JAT1A
A5C57	283-5238-00			CAP,FXD,CER:MLC;150PF,5%,100V,NPO,1206	04222	12061A151JAT1A
A5C58	283-5197-00			CAP,FXD,CER:MLC;330PF,5%,100V,NPO,1206	04222	12061A331JAT1A
A5C59	283-5188-00			CAP,FXD,CER:MLC;100PF,5%,100V,NPO,1206	04222	12061A71JAT1A
A5C60	283-5238-00			CAP,FXD,CER:MLC;150PF,5%,100V,NPO,1206	04222	12061A151JAT1A
A5C61	283-5196-00			CAP,FXD,CER:MLC;47PF,5%,100V,NPO,1206	04222	12061A470JAT1A
A5C62	283-5098-00			CAP,FXD,CER:MLC;0.1UF,+80%-20%,50V,Z5U,1206	04222	12065E104ZAT3A
A5C63	281-5012-00			CAP,VAR,CER:5-40PF,25V,N750+/-500PPM/C,SINGLE TURN, TOP-ADJ	04222	CTZ3S-40C-W5
A5C64	283-5098-00			CAP,FXD,CER:MLC;0.1UF,+80%-20%,50V,Z5U,1206	04222	12065E104ZAT3A
A5C65	283-5098-00			CAP,FXD,CER:MLC;0.1UF,+80%-20%,50V,Z5U,1206	04222	12065E104ZAT3A
A5C66	283-5098-00			CAP,FXD,CER:MLC;0.1UF,+80%-20%,50V,Z5U,1206	04222	12065E104ZAT3A
A5C67	283-5098-00			CAP,FXD,CER:MLC;0.1UF,+80%-20%,50V,Z5U,1206	04222	12065E104ZAT3A
A5C68	283-5098-00			CAP,FXD,CER:MLC;0.1UF,+80%-20%,50V,Z5U,1206	04222	12065E104ZAT3A
A5C69	283-5006-00			CAP,FXD,CER:MLC;5PF,+/-0.25PF,50V,NPO,1206	TK2058	C3216C0G1H050C-
A5C70	283-5187-00			CAP,FXD,CER:MLC;15PF,5%,100V,NPO,1206	04222	12061A150JAT1A
A5C71	283-5108-00			CAP,FXD,CER:MLC;68PF,5%,100V,NPO,1206	04222	12061A680JAT1A
A5C72	283-5185-00			CAP,FXD,CER:MLC;1000PF,5%,50V,NPO,1206	04222	12065A72JAT1A
A5C72	283-5203-00			CAP,FXD,CER:MLC;1000PF,10%,100V,X7R,1206	04222	12061C102KAT1A
A5C73	283-5189-00			CAP,FXD,CER:MLC;220PF,5%,100V,NPO,1206	04222	12061A221JAT1A
A5C75	283-5197-00			CAP,FXD,CER:MLC;330PF,5%,100V,NPO,1206	04222	12061A331JAT1A
A5C76	283-5238-00			CAP,FXD,CER:MLC;150PF,5%,100V,NPO,1206	04222	12061A151JAT1A
A5C77	283-5197-00			CAP,FXD,CER:MLC;330PF,5%,100V,NPO,1206	04222	12061A331JAT1A
A5C78	283-5188-00			CAP,FXD,CER:MLC;100PF,5%,100V,NPO,1206	04222	12061A71JAT1A
A5C79	283-5238-00			CAP,FXD,CER:MLC;150PF,5%,100V,NPO,1206	04222	12061A151JAT1A
A5C80	283-5196-00			CAP,FXD,CER:MLC;47PF,5%,100V,NPO,1206	04222	12061A470JAT1A

Replaceable electrical parts list (Cont.)

Component number	Tektronix part number	Serial no. effective	Serial no. discont'd	Name & description	Mfr. code	Mfr. part number
A5C81	283-5098-00			CAP,FXD,CER:MLC;0.1UF,+80%-20%,50V,Z5U,1206	04222	12065E104ZAT3A
A5C82	281-5012-00			CAP,VAR,CER:5-40PF,25V,N750+/-500PPM/C,SINGLE TURN, TOP-ADJ	04222	CTZ3S-40C-W5
A5C83	283-5098-00			CAP,FXD,CER:MLC;0.1UF,+80%-20%,50V,Z5U,1206	04222	12065E104ZAT3A
A5C84	283-5098-00			CAP,FXD,CER:MLC;0.1UF,+80%-20%,50V,Z5U,1206	04222	12065E104ZAT3A
A5C85	283-5098-00			CAP,FXD,CER:MLC;0.1UF,+80%-20%,50V,Z5U,1206	04222	12065E104ZAT3A
A5C86	283-5098-00			CAP,FXD,CER:MLC;0.1UF,+80%-20%,50V,Z5U,1206	04222	12065E104ZAT3A
A5C87	283-5098-00			CAP,FXD,CER:MLC;0.1UF,+80%-20%,50V,Z5U,1206	04222	12065E104ZAT3A
A5C88	283-5006-00			CAP,FXD,CER:MLC;5PF,+/-0.25PF,50V,NPO,1206	TK2058	C3216C0G1H050C-
A5C89	283-5187-00			CAP,FXD,CER:MLC;15PF,5%,100V,NPO,1206	04222	12061A150JAT1A
A5C90	283-5108-00			CAP,FXD,CER:MLC;68PF,5%,100V,NPO,1206	04222	12061A680JAT1A
A5C91	283-5185-00			CAP,FXD,CER:MLC;1000PF,5%,50V,NPO,1206	04222	12065A72JAT1A
A5C92	283-5189-00			CAP,FXD,CER:MLC;220PF,5%,100V,NPO,1206	04222	12061A221JAT1A
A5C94	283-5197-00			CAP,FXD,CER:MLC;330PF,5%,100V,NPO,1206	04222	12061A331JAT1A
A5C95	283-5238-00			CAP,FXD,CER:MLC;150PF,5%,100V,NPO,1206	04222	12061A151JAT1A
A5C96	283-5197-00			CAP,FXD,CER:MLC;330PF,5%,100V,NPO,1206	04222	12061A331JAT1A
A5C97	283-5188-00			CAP,FXD,CER:MLC;100PF,5%,100V,NPO,1206	04222	12061A71JAT1A
A5C98	283-5238-00			CAP,FXD,CER:MLC;150PF,5%,100V,NPO,1206	04222	12061A151JAT1A
A5C99	290-5034-01			CAP,FXD,ALUM;33UF,20%,10V,5.7MM(0.224)	62643	MVK10VC33RME60T
A5C100	290-5034-01			CAP,FXD,ALUM;33UF,20%,10V,5.7MM(0.224)	62643	MVK10VC33RME60T
A5C110	283-5098-00			CAP,FXD,CER:MLC;0.1UF,+80%-20%,50V,Z5U,1206	04222	12065E104ZAT3A
A5C111	283-5098-00			CAP,FXD,CER:MLC;0.1UF,+80%-20%,50V,Z5U,1206	04222	12065E104ZAT3A
A5C112	283-5098-00			CAP,FXD,CER:MLC;0.1UF,+80%-20%,50V,Z5U,1206	04222	12065E104ZAT3A
A5C113	283-5098-00			CAP,FXD,CER:MLC;0.1UF,+80%-20%,50V,Z5U,1206	04222	12065E104ZAT3A
A5C114	283-5098-00			CAP,FXD,CER:MLC;0.1UF,+80%-20%,50V,Z5U,1206	04222	12065E104ZAT3A
A5C115	283-5098-00			CAP,FXD,CER:MLC;0.1UF,+80%-20%,50V,Z5U,1206	04222	12065E104ZAT3A
A5C116	283-5098-00			CAP,FXD,CER:MLC;0.1UF,+80%-20%,50V,Z5U,1206	04222	12065E104ZAT3A
A5C117	283-5098-00			CAP,FXD,CER:MLC;0.1UF,+80%-20%,50V,Z5U,1206	04222	12065E104ZAT3A
A5C118	283-5098-00			CAP,FXD,CER:MLC;0.1UF,+80%-20%,50V,Z5U,1206	04222	12065E104ZAT3A
A5C119	283-5098-00			CAP,FXD,CER:MLC;0.1UF,+80%-20%,50V,Z5U,1206	04222	12065E104ZAT3A
A5C120	283-5098-00			CAP,FXD,CER:MLC;0.1UF,+80%-20%,50V,Z5U,1206	04222	12065E104ZAT3A
A5C121	283-5098-00			CAP,FXD,CER:MLC;0.1UF,+80%-20%,50V,Z5U,1206	04222	12065E104ZAT3A
A5J1	131-3323-00			CONN,HDR:PCB;MALE,STR,2 X 20,0.1 CTR,0.365D	22526	66506-025
A5J2	131-3378-00			CONN,RF JACK:BNC;50 OHM,FEMALE,RTANG,PCB/REAR PNL,0.5-28 THD,0.625 H X 0.187 TAIL,W/O	00779	227677-1
A5J3	131-3378-00			CONN,RF JACK:BNC;50 OHM,FEMALE,RTANG,PCB/REAR PNL,0.5-28 THD,0.625 H X 0.187 TAIL,W/O	00779	227677-1
A5J4	131-3378-00			CONN,RF JACK:BNC;50 OHM,FEMALE,RTANG,PCB/REAR PNL,0.5-28 THD,0.625 H X 0.187 TAIL,W/O	00779	227677-1

Replaceable electrical parts list (Cont.)

Component number	Tektronix part number	Serial no. effective	Serial no. discont'd	Name & description	Mfr. code	Mfr. part number
A5J5	131-3378-00			CONN,RF JACK:BNC;50 OHM,FEMALE,RTANG,PCB/REAR PNL,0.5-28 THD,0.625 H X 0.187 TAIL,W/O	00779	227677-1
A5L2	120-1941-00			TRANSFORMER,SIG:VARIABLE;L=2.5-2.8UH@4.5MHZ, Q(TYP)=42@7.9MHZ	OJR03	Z-92079A
A5L3	108-5121-00			INDUCTOR,FXD:SIGNAL,SHIELDED;560NH,IDC<440 MA,RDC<0.51 OHM,Q>50,SRF>180 MHZ	TK2058	ACL3225S-R56KT
A5L4	108-5122-00			INDUCTOR,FXD:SIGNAL,MAG SHIELDED;1.8UH,10%, IDC<330 MA,RDC<0.64 OHM,Q>60,SRF>120 MHZ	TK2058	ACL3225S-1R8K-T
A5L5	108-5119-00			INDUCTOR,FXD:SIGNAL,MAG SHIELDED;1.5UH,10%, IDC<360 MA,RDC<0.59 OHM,Q>60,SRF>130 MHZ	TK2058	ACL3225S-1R5K-T
A5L6	108-5122-00			INDUCTOR,FXD:SIGNAL,MAG SHIELDED;1.8UH,10%, IDC<330 MA,RDC<0.64 OHM,Q>60,SRF>120 MHZ	TK2058	ACL3225S-1R8K-T
A5L8	120-1941-00			TRANSFORMER,SIG:VARIABLE;L=2.5-2.8UH@4.5MHZ, Q(TYP)=42@7.9MHZ	OJR03	Z-92079A
A5L9	108-5121-00			INDUCTOR,FXD:SIGNAL,SHIELDED;560NH,IDC<440 MA,RDC<0.51 OHM,Q>50,SRF>180 MHZ	TK2058	ACL3225S-R56KT
A5L10	108-5122-00			INDUCTOR,FXD:SIGNAL,MAG SHIELDED;1.8UH,10%, IDC<330 MA,RDC<0.64 OHM,Q>60,SRF>120 MHZ	TK2058	ACL3225S-1R8K-T
A5L11	108-5119-00			INDUCTOR,FXD:SIGNAL,MAG SHIELDED;1.5UH,10%, IDC<360 MA,RDC<0.59 OHM,Q>60,SRF>130 MHZ	TK2058	ACL3225S-1R5K-T
A5L12	108-5122-00			INDUCTOR,FXD:SIGNAL,MAG SHIELDED;1.8UH,10%, IDC<330 MA,RDC<0.64 OHM,Q>60,SRF>120 MHZ	TK2058	ACL3225S-1R8K-T
A5L14	120-1941-00			TRANSFORMER,SIG:VARIABLE;L=2.5-2.8UH@4.5MH Z,Q(TYP)=42@7.9MHZ	OJR03	Z-92079A
A5L15	108-5121-00			INDUCTOR,FXD:SIGNAL,SHIELDED;560NH,IDC<440 MA,RDC<0.51 OHM,Q>50,SRF>180 MHZ	TK2058	ACL3225S-R56KT
A5L16	108-5122-00			INDUCTOR,FXD:SIGNAL,MAG SHIELDED;1.8UH,10%, IDC<330 MA,RDC<0.64 OHM,Q>60,SRF>120 MHZ	TK2058	ACL3225S-1R8K-T
A5L17	108-5119-00			INDUCTOR,FXD:SIGNAL,MAG SHIELDED;1.5UH,10%, IDC<360 MA,RDC<0.59 OHM,Q>60,SRF>130 MHZ	TK2058	ACL3225S-1R5K-T
A5L18	108-5122-00			INDUCTOR,FXD:SIGNAL,MAG SHIELDED;1.8UH,10%, IDC<330 MA,RDC<0.64 OHM,Q>60,SRF>120 MHZ	TK2058	ACL3225S-1R8K-T
A5L20	120-1941-00			TRANSFORMER,SIG:VARIABLE;L=2.5-2.8UH@4.5MHZ, Q(TYP)=42@7.9MHZ	OJR03	Z-92079A
A5L21	108-5121-00			INDUCTOR,FXD:SIGNAL,SHIELDED;560NH,IDC<440 MA,RDC<0.51 OHM,Q>50,SRF>180 MHZ	TK2058	ACL3225S-R56KT
A5L22	108-5122-00			INDUCTOR,FXD:SIGNAL,MAG SHIELDED;1.8UH,10%, IDC<330 MA,RDC<0.64 OHM,Q>60,SRF>120 MHZ	TK2058	ACL3225S-1R8K-T
A5L23	108-5119-00			INDUCTOR,FXD:SIGNAL,MAG SHIELDED;1.5UH,10%, IDC<360 MA,RDC<0.59 OHM,Q>60,SRF>130 MHZ	TK2058	ACL3225S-1R5K-T
A5L24	108-5122-00			INDUCTOR,FXD:SIGNAL,MAG SHIELDED;1.8UH,10%, IDC<330 MA,RDC<0.64 OHM,Q>60,SRF>120 MHZ	TK2058	ACL3225S-1R8K-T
A5L25	108-5129-00			INDUCTOR,FXD:POWER;10UH,10%,IDC<550 MA,RDC< 0.5 OHM,Q>10,SRF>22 MHZ	TK2058	NLC453232T-100K
A5L26	108-5129-00			INDUCTOR,FXD:POWER;10UH,10%,IDC<550 MA,RDC< 0.5 OHM,Q>10,SRF>22 MHZ	TK2058	NLC453232T-100K

Replaceable electrical parts list (Cont.)

Component number	Tektronix part number	Serial no. effective	Serial no. discount'd	Name & description	Mfr. code	Mfr. part number
A5R1	321-5008-00			RES,FXD:THICK FILM;150 OHM,1%,0.125W,TC=100	50139	BCK1500FT
A5R2	321-5006-00			RES,FXD:THICK FILM;100 OHM,1%,0.125W,TC=100	50139	BCK1000FT
A5R3	321-5008-00			RES,FXD:THICK FILM;150 OHM,1%,0.125W,TC=100	50139	BCK1500FT
A5R4	321-5006-00			RES,FXD:THICK FILM;100 OHM,1%,0.125W,TC=100	50139	BCK1000FT
A5R5	322-3085-07			RES,FXD:METAL FILM;75 OHM,0.1%,0.2W,TC=25 PPM	91637	CCF502-C75ROOBT
A5R6	321-5023-00			RES,FXD:THICK FILM;2.74K OHM,1%,0.125W,TC=100 PPM	50139	BCK2741FT
A5R7	321-5023-00			RES,FXD:THICK FILM;2.74K OHM,1%,0.125W,TC=100 PPM	50139	BCK2741FT
A5R8	321-5266-00			RES,FXD:THICK FILM;11K OHM,1%,0.125W,TC=100	59124	RK73H2B1102FT
A5R9	321-5029-00			RES,FXD:THICK FILM;8.25K OHM,1%,0.125W,TC=100 PPM	50139	BCK8251FT
A5R11	321-5113-00			RES,FXD:THICK FILM;75 OHM,1%,0.125W,TC=100 PPM	56845	CRCW1206-75ROFT
A5R12	321-5113-00			RES,FXD:THICK FILM;75 OHM,1%,0.125W,TC=100 PPM	56845	CRCW1206-75ROFT
A5R13	321-5281-00			RES,FXD:THICK FILM;2K OHM,1%,0.125W,TC=100 PPM	59124	RK73H2B2001FT
A5R14	311-5033-00			RES,VAR,TRMR:CERMET;500 OHM,25%,0.25W,4MM SQ, TOP ADJ	TK2073	G4DT501M
A5R15	321-5019-00			RES,FXD:THICK FILM;1.21K OHM,1%,0.125W,TC=100 PPM	50139	BCK1211FT
A5R16	321-5018-00			RES,FXD:THICK FILM;1.0K OHM,1%,0.125W,TC=100 PPM	50139	BCK1001FT
A5R17	321-5030-00			RES,FXD:THICK FILM;10.0K OHM,1%,0.125W,TC=100 PPM	50139	BCK1002FT
A5R18	321-5030-00			RES,FXD:THICK FILM;10.0K OHM,1%,0.125W,TC=100 PPM	50139	BCK1002FT
A5R19	322-3085-07			RES,FXD:METAL FILM;75 OHM,0.1%,0.2W,TC=25 PPM	91637	CCF502-C75ROOBT
A5R20	321-5023-00			RES,FXD:THICK FILM;2.74K OHM,1%,0.125W,TC=100 PPM	50139	BCK2741FT
A5R21	321-5023-00			RES,FXD:THICK FILM;2.74K OHM,1%,0.125W,TC=100 PPM	50139	BCK2741FT
A5R22	321-5266-00			RES,FXD:THICK FILM;11K OHM,1%,0.125W,TC=100	59124	RK73H2B1102FT
A5R23	321-5029-00			RES,FXD:THICK FILM;8.25K OHM,1%,0.125W,TC=100 PPM	50139	BCK8251FT
A5R25	321-5113-00			RES,FXD:THICK FILM;75 OHM,1%,0.125W,TC=100 PPM	56845	CRCW1206-75ROFT
A5R26	321-5113-00			RES,FXD:THICK FILM;75 OHM,1%,0.125W,TC=100 PPM	56845	CRCW1206-75ROFT
A5R27	321-5281-00			RES,FXD:THICK FILM;2K OHM,1%,0.125W,TC=100 PPM	59124	RK73H2B2001FT
A5R28	311-5033-00			RES,VAR,TRMR:CERMET;500 OHM,25%,0.25W,4MM SQ, TOP ADJ	TK2073	G4DT501M
A5R29	321-5019-00			RES,FXD:THICK FILM;1.21K OHM,1%,0.125W,TC=100 PPM	50139	BCK1211FT
A5R30	321-5018-00			RES,FXD:THICK FILM;1.0K OHM,1%,0.125W,TC=100 PPM	50139	BCK1001FT
A5R31	321-5030-00			RES,FXD:THICK FILM;10.0K OHM,1%,0.125W,TC=100 PPM	50139	BCK1002FT
A5R32	321-5030-00			RES,FXD:THICK FILM;10.0K OHM,1%,0.125W,TC=100 PPM	50139	BCK1002FT
A5R33	322-3085-07			RES,FXD:METAL FILM;75 OHM,0.1%,0.2W,TC=25 PPM	91637	CCF502-C75ROOBT
A5R34	321-5023-00			RES,FXD:THICK FILM;2.74K OHM,1%,0.125W,TC=100 PPM	50139	BCK2741FT
A5R35	321-5023-00			RES,FXD:THICK FILM;2.74K OHM,1%,0.125W,TC=100 PPM	50139	BCK2741FT
A5R36	321-5266-00			RES,FXD:THICK FILM;11K OHM,1%,0.125W,TC=100	59124	RK73H2B1102FT
A5R37	321-5029-00			RES,FXD:THICK FILM;8.25K OHM,1%,0.125W,TC=100 PPM	50139	BCK8251FT
A5R39	321-5113-00			RES,FXD:THICK FILM;75 OHM,1%,0.125W,TC=100 PPM	56845	CRCW1206-75ROFT
A5R40	321-5113-00			RES,FXD:THICK FILM;75 OHM,1%,0.125W,TC=100 PPM	56845	CRCW1206-75ROFT

Replaceable electrical parts list (Cont.)

Component number	Tektronix part number	Serial no. effective	Serial no. discontin'd	Name & description	Mfr. code	Mfr. part number
A5R41	321-5281-00			RES,FXD:THICK FILM;2K OHM,1%,0.125W,TC=100 PPM	59124	RK73H2B2001FT
A5R42	311-5033-00			RES,VAR,TRMR:CERMET;500 OHM,25%,0.25W,4MM SQ, TOP ADJ	TK2073	G4DT501M
A5R43	321-5019-00			RES,FXD:THICK FILM;1.21K OHM,1%,0.125W,TC=100 PPM	50139	BCK1211FT
A5R44	321-5018-00			RES,FXD:THICK FILM;1.0K OHM,1%,0.125W,TC=100 PPM	50139	BCK1001FT
A5R45	321-5030-00			RES,FXD:THICK FILM;10.0K OHM,1%,0.125W,TC=100 PPM	50139	BCK1002FT
A5R46	321-5030-00			RES,FXD:THICK FILM;10.0K OHM,1%,0.125W,TC=100 PPM	50139	BCK1002FT
A5R47	322-3085-07			RES,FXD:METAL FILM;75 OHM,0.1%,0.2W,TC=25 PPM	91637	CCF502-C75ROOBT
A5R48	321-5023-00			RES,FXD:THICK FILM;2.74K OHM,1%,0.125W,TC=100 PPM	50139	BCK2741FT
A5R49	321-5023-00			RES,FXD:THICK FILM;2.74K OHM,1%,0.125W,TC=100 PPM	50139	BCK2741FT
A5R50	321-5266-00			RES,FXD:THICK FILM;11K OHM,1%,0.125W,TC=100	59124	RK73H2B1102FT
A5R51	321-5029-00			RES,FXD:THICK FILM;8.25K OHM,1%,0.125W,TC=100 PPM	50139	BCK8251FT
A5R53	321-5113-00			RES,FXD:THICK FILM;75 OHM,1%,0.125W,TC=100 PPM	56845	CRCW1206-75ROFT
A5R54	321-5113-00			RES,FXD:THICK FILM;75 OHM,1%,0.125W,TC=100 PPM	56845	CRCW1206-75ROFT
A5R55	321-5281-00			RES,FXD:THICK FILM;2K OHM,1%,0.125W,TC=100 PPM	59124	RK73H2B2001FT
A5R56	311-5033-00			RES,VAR,TRMR:CERMET;500 OHM,25%,0.25W,4MM SQ, TOP ADJ	TK2073	G4DT501M
A5R57	321-5019-00			RES,FXD:THICK FILM;1.21K OHM,1%,0.125W,TC=100 PPM	50139	BCK1211FT
A5R58	321-5018-00			RES,FXD:THICK FILM;1.0K OHM,1%,0.125W,TC=100 PPM	50139	BCK1001FT
A5R59	321-5030-00			RES,FXD:THICK FILM;10.0K OHM,1%,0.125W,TC=100 PPM	50139	BCK1002FT
A5R60	321-5030-00			RES,FXD:THICK FILM;10.0K OHM,1%,0.125W,TC=100 PPM	50139	BCK1002FT
A5R61	321-5050-00			RES,FXD:THICK FILM;33.2 OHM,1%,0.125W,TC=100 PPM	57668	MCR18FWEA33E2
A5R62	321-5050-00			RES,FXD:THICK FILM;33.2 OHM,1%,0.125W,TC=100 PPM	57668	MCR18FWEA33E2
A5R63	321-5050-00			RES,FXD:THICK FILM;33.2 OHM,1%,0.125W,TC=100 PPM	57668	MCR18FWEA33E2
A5R64	321-5050-00			RES,FXD:THICK FILM;33.2 OHM,1%,0.125W,TC=100 PPM	57668	MCR18FWEA33E2
A5R65	321-5012-00			RES,FXD:THICK FILM;332 OHM,1%,0.125W,TC=100	50139	BCK3320FT
A5R66	321-5014-00			RES,FXD:THICK FILM;475 OHM,1%,0.125W,TC=100	50139	BCK4750FT
A5R67	321-5014-00			RES,FXD:THICK FILM;475 OHM,1%,0.125W,TC=100	50139	BCK4750FT
A5R68	321-5012-00			RES,FXD:THICK FILM;332 OHM,1%,0.125W,TC=100	50139	BCK3320FT
A5R69	321-5050-00			RES,FXD:THICK FILM;33.2 OHM,1%,0.125W,TC=100 PPM	57668	MCR18FWEA33E2
A5R70	321-5050-00			RES,FXD:THICK FILM;33.2 OHM,1%,0.125W,TC=100 PPM	57668	MCR18FWEA33E2
A5TP1	214-4085-00			TERM,TEST POINT:0.070 ID,0.220 H,0.063 DIAP CB,0.015 X 0.032 BRASS,W/RED NYLON COLLAR	26364	104-01-02
A5TP2	214-4085-00			TERM,TEST POINT:0.070 ID,0.220 H,0.063 DIAP CB,0.015 X 0.032 BRASS,W/RED NYLON COLLAR	26364	104-01-02
A5TP3	214-4085-00			TERM,TEST POINT:0.070 ID,0.220 H,0.063 DIAP CB,0.015 X 0.032 BRASS,W/RED NYLON COLLAR	26364	104-01-02
A5TP4	214-4085-00			TERM,TEST POINT:0.070 ID,0.220 H,0.063 DIAP CB,0.015 X 0.032 BRASS,W/RED NYLON COLLAR	26364	104-01-02
A5U1	156-5324-01			IC,DIGITAL:ECL,TRANSLATOR:QUAD ECL-TO-TTL	04713	MC10H125FNR2

Replaceable electrical parts list (Cont.)

Component number	Tektronix part number	Serial no. effective	Serial no. discont'd	Name & description	Mfr. code	Mfr. part number
A5U2	160-9919-00			IC,DIGITAL:CMOS,PLD,EEPLD,7032,32 M/C,32 I/O,4 IN,15NS,PRGM 156-6500-00,EPM7032-15,PLCC44,T	TK0198	160991900
	136-1229-00			SOCKET,PLCC:SMD,44 POS,0.05 CTR,0.186 H,TIN,W/O PLZ POSTS,TUBE PACK	00779	821979-3
A5U3	156-6561-00			IC,CONVERTER:BIPOLAR,D/A;10 BIT,60MHZ,CURRENT OUT,LATCHED,LOW POWER,W/REFERENCE	61271	MB40760PF
A5U4	156-6905-00			IC,ASIC:CMOS,CUSTOM;PAL ENCODER,ADG313	27014	MM9423-VUL
A5U5	160-9918-00			IC,MEMORY:CMOS,EPROM,256K X 8,150NS,PRGM 156-6302-00,27C020,PLCC32	TK0198	160991800
	136-5011-00			SOCKET,PLCC:SMD;32 POS,0.05 CTR,0.800X 0.700 INCH WIDE,0.200 H,BE/CU,TIN,W/O PLZ POSTS	22526	69802-132
A5U6	156-6274-01			IC,MEMORY:CMOS,SRAM;32K X 8,25NS	80009	156627401
A5U7	156-6560-00			IC,LINEAR:BIPOLAR,OP-AMP;CURRENT FEED-BACK,100MHZ,HIGH OUTPUT CURRENT	13919	OPA603AU
A5U8	156-6560-00			IC,LINEAR:BIPOLAR,OP-AMP;CURRENT FEED-BACK,100MHZ,HIGH OUTPUT CURRENT	13919	OPA603AU
A5U9	156-6561-00			IC,CONVERTER:BIPOLAR,D/A;10 BIT,60MHZ,CURRENT OUT,LATCHED,LOW POWER,W/REFERENCE	61271	MB40760PF
A5U10	156-6905-00			IC,ASIC:CMOS,CUSTOM;PAL ENCODER,ADG313	27014	MM9423-VUL
A5U11	160-9918-00			IC,MEMORY:CMOS,EPROM,256K X 8,150NS,PRGM 156-6302-00,27C020,PLCC32	TK0198	160991800
	136-5011-00			SOCKET,PLCC:SMD;32 POS,0.05 CTR,0.800X 0.700 INCH WIDE,0.200 H,BE/CU,TIN,W/O PLZ POSTS	22526	69802-132
A5U12	156-6274-01			IC,MEMORY:CMOS,SRAM;32K X 8,25NS	80009	156627401
A5U13	156-6560-00			IC,LINEAR:BIPOLAR,OP-AMP;CURRENT FEED-BACK,100MHZ,HIGH OUTPUT CURRENT	13919	OPA603AU
A5U14	156-6560-00			IC,LINEAR:BIPOLAR,OP-AMP;CURRENT FEED-BACK,100MHZ,HIGH OUTPUT CURRENT	13919	OPA603AU
A5U15	156-6561-00			IC,CONVERTER:BIPOLAR,D/A;10 BIT,60MHZ,CURRENT OUT,LATCHED,LOW POWER,W/REFERENCE	61271	MB40760PF
A5U16	156-6905-00			IC,ASIC:CMOS,CUSTOM;PAL ENCODER,ADG313	27014	MM9423-VUL
A5U17	160-9918-00			IC,MEMORY:CMOS,EPROM,256K X 8,150NS,PRGM 156-6302-00,27C020,PLCC32	TK0198	160991800
	136-5011-00			SOCKET,PLCC:SMD;32 POS,0.05 CTR,0.800X 0.700 INCH WIDE,0.200 H,BE/CU,TIN,W/O PLZ POSTS	22526	69802-132
A5U18	156-6274-01			IC,MEMORY:CMOS,SRAM;32K X 8,25NS	80009	156627401
A5U19	156-6560-00			IC,LINEAR:BIPOLAR,OP-AMP;CURRENT FEED-BACK,100MHZ,HIGH OUTPUT CURRENT	13919	OPA603AU
A5U20	156-6560-00			IC,LINEAR:BIPOLAR,OP-AMP;CURRENT FEED-BACK,100MHZ,HIGH OUTPUT CURRENT	13919	OPA603AU
A5U21	156-6561-00			IC,CONVERTER:BIPOLAR,D/A;10 BIT,60MHZ,CURRENT OUT,LATCHED,LOW POWER,W/REFERENCE	61271	MB40760PF
A5U22	156-6905-00			IC,ASIC:CMOS,CUSTOM;PAL ENCODER,ADG313	27014	MM9423-VUL
A5U23	160-9918-00			IC,MEMORY:CMOS,EPROM,256K X 8,150NS,PRGM 156-6302-00,27C020,PLCC32	TK0198	160991800

Replaceable Electrical Parts

Replaceable electrical parts list (Cont.)

Component number	Tektronix part number	Serial no. effective	Serial no. discontinued	Name & description	Mfr. code	Mfr. part number
	136-5011-00			SOCKET,PLCC:SMD;32 POS,0.05 CTR,0.800X 0.700 INCH WIDE,0.200 H,BE/CU,TIN,W/O PLZ POSTS	22526	69802-132
A5U24	156-6274-01			IC,MEMORY:CMOS,SRAM;32K X 8,25NS	80009	156627401
A5U25	156-6560-00			IC,LINER:BIPOlar,OP-AMP:CURRENT FEED-BACK,100MHZ,HIGH OUTPUT CURRENT	13919	OPA603AU
A5U26	156-6560-00			IC,LINER:BIPOlar,OP-AMP:CURRENT FEED-BACK,100MHZ,HIGH OUTPUT CURRENT	13919	OPA603AU

Replaceable electrical parts list

Component number	Tektronix part number	Serial no. effective	Serial no. discont'd	Name & description	Mfr. code	Mfr. part number
A6	671-3126-01		B020533	CKT BD ASSY:TEST SIGNALBOARD	80009	671312601
A6	671-3126-02	B020534	B021330	CKT BD ASSY:TEST SIGNALBOARD	80009	671312602
A6	671-3126-03	B021331		CKT BD ASSY:TEST SIGNALBOARD (OPTION 02 ONLY)	80009	671312602
A6C1	283-5098-00			CAP,FXD,CER:MLC;0.1UF,+80%-20%,50V,Z5U,1206	04222	12065E104ZAT3A
A6C2	283-5098-00			CAP,FXD,CER:MLC;0.1UF,+80%-20%,50V,Z5U,1206	04222	12065E104ZAT3A
A6C3	283-5098-00			CAP,FXD,CER:MLC;0.1UF,+80%-20%,50V,Z5U,1206	04222	12065E104ZAT3A
A6C4	283-5098-00			CAP,FXD,CER:MLC;0.1UF,+80%-20%,50V,Z5U,1206	04222	12065E104ZAT3A
A6C5	290-0963-00			CAP,FXD,ALUM:220UF,+50-20%,25WVDC,10 X12MM	55680	UVX1V221MPA
A6C6	290-0963-00			CAP,FXD,ALUM:220UF,+50-20%,25WVDC,10 X12MM	55680	UVX1V221MPA
A6C7	290-0963-00			CAP,FXD,ALUM:220UF,+50-20%,25WVDC,10 X12MM	55680	UVX1V221MPA
A6C8	283-5098-00			CAP,FXD,CER:MLC;0.1UF,+80%-20%,50V,Z5U,1206	04222	12065E104ZAT3A
A6C9	283-5098-00			CAP,FXD,CER:MLC;0.1UF,+80%-20%,50V,Z5U,1206	04222	12065E104ZAT3A
A6C10	283-5098-00			CAP,FXD,CER:MLC;0.1UF,+80%-20%,50V,Z5U,1206	04222	12065E104ZAT3A
A6C11	283-5098-00			CAP,FXD,CER:MLC;0.1UF,+80%-20%,50V,Z5U,1206	04222	12065E104ZAT3A
A6C12	283-5098-00			CAP,FXD,CER:MLC;0.1UF,+80%-20%,50V,Z5U,1206	04222	12065E104ZAT3A
A6C13	283-5098-00			CAP,FXD,CER:MLC;0.1UF,+80%-20%,50V,Z5U,1206	04222	12065E104ZAT3A
A6C14	283-5098-00			CAP,FXD,CER:MLC;0.1UF,+80%-20%,50V,Z5U,1206	04222	12065E104ZAT3A
A6C15	283-5098-00			CAP,FXD,CER:MLC;0.1UF,+80%-20%,50V,Z5U,1206	04222	12065E104ZAT3A
A6C16	283-5098-00			CAP,FXD,CER:MLC;0.1UF,+80%-20%,50V,Z5U,1206	04222	12065E104ZAT3A
A6C17	283-5098-00			CAP,FXD,CER:MLC;0.1UF,+80%-20%,50V,Z5U,1206	04222	12065E104ZAT3A
A6C18	283-5098-00			CAP,FXD,CER:MLC;0.1UF,+80%-20%,50V,Z5U,1206	04222	12065E104ZAT3A
A6C19	283-5203-00			CAP,FXD,CER:MLC;1000PF,10%,100V,X7R,1206	04222	12061C102KAT1A
A6C20	283-5203-00			CAP,FXD,CER:MLC;1000PF,10%,100V,X7R,1206	04222	12061C102KAT1A
A6C21	283-5003-00			CAP,FXD,CER:MLC;0.01UF,10%,50V,X7R,1206	TK2058	C3216X7R1H103K-
A6C22	283-5003-00			CAP,FXD,CER:MLC;0.01UF,10%,50V,X7R,1206	TK2058	C3216X7R1H103K-
A6C23	283-5202-00			CAP,FXD,CER:MLC;0.022UF,10%,50V,X7R,1206,SMD,8MM	04222	12065C223KAT1A
A6C24	283-5203-00			CAP,FXD,CER:MLC;1000PF,10%,100V,X7R,1206	04222	12061C102KAT1A
A6C25	283-5203-00			CAP,FXD,CER:MLC;1000PF,10%,100V,X7R,1206	04222	12061C102KAT1A
A6C27	283-5098-00			CAP,FXD,CER:MLC;0.1UF,+80%-20%,50V,Z5U,1206	04222	12065E104ZAT3A
A6C28	283-5267-00			CAP,FXD,CER:MLC;1UF,+80%-20%,25V,Y5V,1206	04222	12063G105ZAT1A
A6C29	283-5267-00			CAP,FXD,CER:MLC;1UF,+80%-20%,25V,Y5V,1206	04222	12063G105ZAT1A
A6C30	283-5203-00			CAP,FXD,CER:MLC;1000PF,10%,100V,X7R,1206	04222	12061C102KAT1A
A6C31	283-5098-00			CAP,FXD,CER:MLC;0.1UF,+80%-20%,50V,Z5U,1206	04222	12065E104ZAT3A
A6C32	283-5098-00			CAP,FXD,CER:MLC;0.1UF,+80%-20%,50V,Z5U,1206	04222	12065E104ZAT3A
A6C33	290-0963-00			CAP,FXD,ALUM:220UF,+50-20%,25WVDC,10 X12MM	55680	UVX1V221MPA
A6C34	283-5283-00			CAP,FXD,CER:MLC;1.5PF,+/- .25PF,100V,NPO,.120X.060	04222	12061A1R5CAT*A
A6C35	283-5283-00			CAP,FXD,CER:MLC;1.5PF,+/- .25PF,100V,NPO,.120X.060	04222	12061A1R5CAT*A
A6C36	283-5341-00			CAP,FXD,CER:MLC;4.7PF,.25PF,100V,NPO	04222	12061A4R7CATMA

Replaceable electrical parts list (Cont.)

Component number	Tektronix part number	Serial no. effective	Serial no. discont'd	Name & description	Mfr. code	Mfr. part number
A6C37	283-5098-00			CAP,FXD,CER:MLC;0.1UF,+80%-20%,50V,Z5U,1206	04222	12065E104ZAT3A
A6C38	283-5098-00			CAP,FXD,CER:MLC;0.1UF,+80%-20%,50V,Z5U,1206	04222	12065E104ZAT3A
A6C39	283-5098-00			CAP,FXD,CER:MLC;0.1UF,+80%-20%,50V,Z5U,1206	04222	12065E104ZAT3A
A6C40	283-5098-00			CAP,FXD,CER:MLC;0.1UF,+80%-20%,50V,Z5U,1206	04222	12065E104ZAT3A
A6C41	283-5098-00			CAP,FXD,CER:MLC;0.1UF,+80%-20%,50V,Z5U,1206	04222	12065E104ZAT3A
A6C42	283-5098-00			CAP,FXD,CER:MLC;0.1UF,+80%-20%,50V,Z5U,1206	04222	12065E104ZAT3A
A6C43	283-5098-00			CAP,FXD,CER:MLC;0.1UF,+80%-20%,50V,Z5U,1206	04222	12065E104ZAT3A
A6C44	283-5098-00			CAP,FXD,CER:MLC;0.1UF,+80%-20%,50V,Z5U,1206	04222	12065E104ZAT3A
A6C45	283-5098-00			CAP,FXD,CER:MLC;0.1UF,+80%-20%,50V,Z5U,1206	04222	12065E104ZAT3A
A6C46	283-5098-00			CAP,FXD,CER:MLC;0.1UF,+80%-20%,50V,Z5U,1206	04222	12065E104ZAT3A
A6C47	283-5098-00			CAP,FXD,CER:MLC;0.1UF,+80%-20%,50V,Z5U,1206	04222	12065E104ZAT3A
A6J1	131-3323-00			CONN,HDR:PCB;MALE,STR,2 X 20,0.1 CTR,0.365D	22526	66506-025
A6J5	131-0391-00			CONN,RF JACK:SMB;MALE,STR,PCB,GOLD/GOLD,0.293 H X 0.155 TAIL,3/0.045 SQ TAIL 0.038 DIA CTR COND,0.2 SQ PCB,0.312 HEX	24931	32JR105-1
A6J6	131-0391-00			CONN,RF JACK:SMB;MALE,STR,PCB,GOLD/GOLD,0.293 H X 0.155 TAIL,3/0.045 SQ TAIL 0.038 DIA CTR COND,0.2 SQ PCB,0.312 HEX	24931	32JR105-1
A6L1	108-5000-00			INDUCTOR,FXD:SIGNAL;1UH,5%,I<0.45A,RDC<0.5 OHM,Q>50,SRF>140MHZ	TK2058	NL453232T-1R0J-
A6R1	321-5006-00			RES,FXD:THICK FILM;100 OHM,1%,0.125W,TC=100	50139	BCK1000FT
A6R2	321-5008-00			RES,FXD:THICK FILM;150 OHM,1%,0.125W,TC=100	50139	BCK1500FT
A6R3	321-5006-00			RES,FXD:THICK FILM;100 OHM,1%,0.125W,TC=100	50139	BCK1000FT
A6R4	321-5008-00			RES,FXD:THICK FILM;150 OHM,1%,0.125W,TC=100	50139	BCK1500FT
A6R5	321-5012-00			RES,FXD:THICK FILM;332 OHM,1%,0.125W,TC=100	50139	BCK3320FT
A6R6	321-5014-00			RES,FXD:THICK FILM;475 OHM,1%,0.125W,TC=100	50139	BCK4750FT
A6R7	321-5012-00			RES,FXD:THICK FILM;332 OHM,1%,0.125W,TC=100	50139	BCK3320FT
A6R8	321-5014-00			RES,FXD:THICK FILM;475 OHM,1%,0.125W,TC=100	50139	BCK4750FT
A6R9	321-5018-00			RES,FXD:THICK FILM;1.0K OHM,1%,0.125W,TC=100 PPM	50139	BCK1001FT
A6R10	321-5030-00		671-3126-02	RES,FXD:THICK FILM;1.0K OHM,1%,0.125W,TC=100 PPM	50139	BCK1002FT
A6R10	321-5018-00	671-3126-03		RES,FXD:THICK FILM;1.0K OHM,1%,0.125W,TC=100 PPM	50139	BCK1002FT
A6R11	321-5030-00			RES,FXD:THICK FILM;10.0K OHM,1%,0.125W,TC=100 PPM	50139	BCK1002FT
A6R12	321-5030-00		671-3126-02	RES,FXD:THICK FILM;1.0K OHM,1%,0.125W,TC=100 PPM	50139	BCK1002FT
A6R12	321-5018-00	671-3126-03		RES,FXD:THICK FILM;1.0K OHM,1%,0.125W,TC=100 PPM	50139	BCK1002FT
A6R13	321-5014-00			RES,FXD:THICK FILM;475 OHM,1%,0.125W,TC=100	50139	BCK4750FT
A6R14	321-5008-00			RES,FXD:THICK FILM;150 OHM,1%,0.125W,TC=100	50139	BCK1500FT
A6R15	321-5010-00			RES,FXD:THICK FILM;221 OHM,1%,0.125W,TC=100	50139	BCK221FT
A6R16	321-5010-00			RES,FXD:THICK FILM;221 OHM,1%,0.125W,TC=100	50139	BCK221FT
A6R17	321-5008-00			RES,FXD:THICK FILM;150 OHM,1%,0.125W,TC=100	50139	BCK1500FT
A6R18	321-5008-00			RES,FXD:THICK FILM;150 OHM,1%,0.125W,TC=100	50139	BCK1500FT

Replaceable electrical parts list (Cont.)

Component number	Tektronix part number	Serial no. effective	Serial no. discont'd	Name & description	Mfr. code	Mfr. part number
A6R19	321-5045-00			RES,FXD:THICK FILM;68.1 OHM,1%,0.125W,TC=100 PPM	50139	BCD68R1FT
A6R20	321-5045-00			RES,FXD:THICK FILM;68.1 OHM,1%,0.125W,TC=100 PPM	50139	BCD68R1FT
A6R21	321-5018-00			RES,FXD:THICK FILM;1.0K OHM,1%,0.125W,TC=100 PPM	50139	BCK1001FT
A6R22	321-5024-00			RES,FXD:THICK FILM;3.32K OHM,1%,0.125W,TC=100 PPM	50139	BCK3321FT
A6R23	321-5028-00			RES,FXD:THICK FILM;6.81K OHM,1%,0.125W,TC=100 PPM	50139	BCK6811FT
A6R24	321-5051-00			RES,FXD:THICK FILM;0 OHM,1%,0.125W,TC=100 PPM	09969	CRCW1206 JUMPER
A6R25	321-5018-00			RES,FXD:THICK FILM;1.0K OHM,1%,0.125W,TC=100 PPM	50139	BCK1001FT
A6R26	321-5051-00			RES,FXD:THICK FILM;0 OHM,1%,0.125W,TC=100 PPM	09969	CRCW1206 JUMPER
A6R27	321-5050-00			RES,FXD:THICK FILM;33.2 OHM,1%,0.125W,TC=100 PPM	57668	MCR18FWEA33E2
A6R28	321-5050-00			RES,FXD:THICK FILM;33.2 OHM,1%,0.125W,TC=100 PPM	57668	MCR18FWEA33E2
A6R29	321-5045-00			RES,FXD:THICK FILM;68.1 OHM,1%,0.125W,TC=100 PPM	50139	BCD68R1FT
A6R30	321-5051-00			RES,FXD:THICK FILM;0 OHM,1%,0.125W,TC=100 PPM	09969	CRCW1206 JUMPER
A6R31	321-5051-00			RES,FXD:THICK FILM;0 OHM,1%,0.125W,TC=100 PPM	09969	CRCW1206 JUMPER
A6R32	321-5051-00			RES,FXD:THICK FILM;0 OHM,1%,0.125W,TC=100 PPM	09969	CRCW1206 JUMPER
A6R34	322-3289-00	671-3126-02	671-3126-02	RES,METAL FILM;1.0K OHM,1%,0.2W,TC=100 PPM,OPT 02	57668	671312602
A6R34	322-3193-00	671-3126-03		RES,METAL FILM;1.0K OHM,1%,0.2W,TC=100 PPM,OPT 02	57668	CRB20T68EFX1001
A6R35	322-3289-00	671-3126-02		RES,METAL FILM;1.0K OHM,1%,0.2W,TC=100 PPM,OPT 02	57668	CRB20T29EFX1002
A6TP1	214-4085-00			TERM,TEST POINT:0.070 ID,0.220 H,0.063 DIAP CB,0.015 X 0.032 BRASS,W/RED NYLON COLLAR	26364	104-01-02
A6TP2	214-4085-00			TERM,TEST POINT:0.070 ID,0.220 H,0.063 DIAP CB,0.015 X 0.032 BRASS,W/RED NYLON COLLAR	26364	104-01-02
A6TP3	214-4085-00			TERM,TEST POINT:0.070 ID,0.220 H,0.063 DIAP CB,0.015 X 0.032 BRASS,W/RED NYLON COLLAR	26364	104-01-02
A6TP4	214-4085-00			TERM,TEST POINT:0.070 ID,0.220 H,0.063 DIAP CB,0.015 X 0.032 BRASS,W/RED NYLON COLLAR	26364	104-01-02
A6TP5	214-4085-00			TERM,TEST POINT:0.070 ID,0.220 H,0.063 DIAP CB,0.015 X 0.032 BRASS,W/RED NYLON COLLAR	26364	104-01-02
A6U1	156-5324-01			IC,DIGITAL:ECL,TRANSLATOR:QUAD ECL-TO-TTL	04713	MC10H125FN2
A6U2	156-5070-01			IC,DIGITAL:HCTCMOS,BFR;OCTAL BFR/DRIVER, 3-STATE	0JR04	TC74HCT244AFW(E
A6U3	156-5070-01			IC,DIGITAL:HCTCMOS,BFR;OCTAL BFR/DRIVER, 3-STATE	0JR04	TC74HCT244AFW(E
A6U4	156-5071-01			IC,DIGITAL:HCTCMOS,TRANSCEIVER;OCTAL,3-STATE	0JR04	TC74HCT245AFW(E
A6U5	156-5071-01			IC,DIGITAL:HCTCMOS,TRANSCEIVER;OCTAL,3-STATE	0JR04	TC74HCT245AFW(E
A6U6	156-5143-01			IC,DIGITAL:HCTCMOS,FLIP FLOP;OCTAL D-TYPE,3-STATE	0JR04	TC74HCT374AFN(E
A6U9	156-6780-00		671-3126-00	IC,DGTL:CMOS,PLD;EEPLD,7128E,128 M/C,64,I/O,4 IN,15NS	67183	EPM7128ELC84-15
A6U9	163-0296-00	671-3126-01		IC,DIGITAL:CMOS,PLD,EEPLD,7128E,128 M/C,64/I/O,4IN,15NS,PRGM 156-6780-00,EPM7128E-15,PLCC84,	TK0198	163029600
	136-5010-00			SOCKET,PLCC:SMD;84 POS,0.05 CTR,0.186H,TIN,W/PLZ POST,TUBE PACK	22526	69802-084
A6U10	156-6780-00		671-3126-00	IC,DGTL:CMOS,PLD;EEPLD,7128E,128 M/C,64,I/O,4 IN,15NS	67183	EPM7128ELC84-15
A6U10	163-0297-01	671-3126-01		IC,DIGITAL:CMOS,PLD,EEPLD,7128E,128 M/C,64 I/O,4 IN,15NS,PRGM 156-6780-00,EPM7128E-15,PLCC8	80009	163-0297-01

Replaceable electrical parts list (Cont.)

Component number	Tektronix part number	Serial no. effective	Serial no. discont'd	Name & description	Mfr. code	Mfr. part number
	136-5010-00			SOCKET,PLCC:SMD;84 POS,0.05 CTR,0.186H,TIN,W/PLZ POST,TUBE PACK	22526	69802-084
A6U11	156-6274-01			IC,MEMORY:CMOS,SRAM;32K X 8,25NS	80009	156627401
A6U12	156-6547-00		671-3126-00	IC,MEMORY:CMOS,EPROM;64K X 8,150NS	34335	AM27C512-150JC
A6U12	163-0300-00	671-3126-01		IC,MEMORY:CMOS,EPROM,64K X 8,150NS,PRGM156-6547-00,27C512,PLCC32	TK0198	163030000
	136-5011-00			SOCKET,PLCC:SMD;32 POS,0.05 CTR,0.800X 0.700 INCH WIDE,0.200 H,BE/CU,TIN,W/O PLZ POSTS	22526	69802-132
A6U13	156-6274-01			IC,MEMORY:CMOS,SRAM;32K X 8,25NS	80009	156627401
A6U14	156-5070-01			IC,DIGITAL:HCTCMOS,BFR;OCTAL BFR/DRIVER, 3-STATE	0JR04	TC74HCT244AFW(E
A6U15	156-5070-01			IC,DIGITAL:HCTCMOS,BFR;OCTAL BFR/DRIVER, 3-STATE	0JR04	TC74HCT244AFW(E
A6U16	156-5071-01			IC,DIGITAL:HCTCMOS,TRANSCEIVER;OCTAL,3-STATE	0JR04	TC74HCT245AFW(E
A6U17	156-5071-01			IC,DIGITAL:HCTCMOS,TRANSCEIVER;OCTAL,3-STATE	0JR04	TC74HCT245AFW(E
A6U18	156-5164-01			IC,DIGITAL:FTTL,GATES;QUAD 2-INPUT NAND,OC	01295	SN74F38DR
A6U19	156-6794-00			IC,MEMORY:CMOS,SRAM;32K X 8,15NS,5C2568,SOJ28.300	TK2519	AS7C256-15JC
A6U20	156-6794-00			IC,MEMORY:CMOS,SRAM;32K X 8,15NS,5C2568,SOJ28.300	TK2519	AS7C256-15JC
A6U21	156-6718-00			IC,DIGITAL:CMOS,PLD;FPGA,XC3100A FAMILY,3195,484 CLBS,176 IOBS,70 I/O,230 MHZ	68994	XC3195A-4PC84C
A6U22	156-6668-00			IC,MISC:ECL,MISC;GENLINX CABLE DRIVER WITHTWO ADJUSTABLE OUTPUTS	37964	GS9008
A6U23	155-0416-00			IC,ASIC:BIPOLAR,VIDEO SERIALZER;FULL CUSTOM,M763	TK2598	155041600

Replaceable electrical parts list

Component number	Tektronix part number	Serial no. effective	Serial no. discont'd	Name & description	Mfr. code	Mfr. part number
A7	671-2059-00			CIRCUIT BD ASSY:SERIAL FILTER	80009	671205900
A7C1	283-0197-02			CAP,FXD,CER DI:470PF,5%,50V	04222	SR591A471JAAAP1
A7C2	283-0197-02			CAP,FXD,CER DI:470PF,5%,50V	04222	SR591A471JAAAP1
A7C3	283-0197-02			CAP,FXD,CER DI:470PF,5%,50V	04222	SR591A471JAAAP1
A7C4	283-0197-02			CAP,FXD,CER DI:470PF,5%,50V	04222	SR591A471JAAAP1
A7C5	283-0197-02			CAP,FXD,CER DI:470PF,5%,50V	04222	SR591A471JAAAP1
A7C6	283-0197-02			CAP,FXD,CER DI:470PF,5%,50V	04222	SR591A471JAAAP1
A7C7	283-0197-02			CAP,FXD,CER DI:470PF,5%,50V	04222	SR591A471JAAAP1
A7C8	283-0197-02			CAP,FXD,CER DI:470PF,5%,50V	04222	SR591A471JAAAP1
A7C9	283-0197-02			CAP,FXD,CER DI:470PF,5%,50V	04222	SR591A471JAAAP1
A7C10	283-0197-02			CAP,FXD,CER DI:470PF,5%,50V	04222	SR591A471JAAAP1
A7C11	283-0197-02			CAP,FXD,CER DI:470PF,5%,50V	04222	SR591A471JAAAP1
A7C12	283-0197-02			CAP,FXD,CER DI:470PF,5%,50V	04222	SR591A471JAAAP1
A7C13	283-0197-02			CAP,FXD,CER DI:470PF,5%,50V	04222	SR591A471JAAAP1
A7C14	283-0197-02			CAP,FXD,CER DI:470PF,5%,50V	04222	SR591A471JAAAP1
A7C15	283-0197-02			CAP,FXD,CER DI:470PF,5%,50V	04222	SR591A471JAAAP1
A7C16	283-0197-02			CAP,FXD,CER DI:470PF,5%,50V	04222	SR591A471JAAAP1
A7C17	283-0197-02			CAP,FXD,CER DI:470PF,5%,50V	04222	SR591A471JAAAP1
A7C18	283-0197-02			CAP,FXD,CER DI:470PF,5%,50V	04222	SR591A471JAAAP1
A7FL1	119-3580-00			FILTER,EMI:	TK2058	ZJSR-5101-102TA
A7FL2	119-3580-00			FILTER,EMI:	TK2058	ZJSR-5101-102TA
A7FL3	119-3580-00			FILTER,EMI:	TK2058	ZJSR-5101-102TA
A7FL4	119-3580-00			FILTER,EMI:	TK2058	ZJSR-5101-102TA
A7FL5	119-3580-00			FILTER,EMI:	TK2058	ZJSR-5101-102TA
A7FL6	119-3580-00			FILTER,EMI:	TK2058	ZJSR-5101-102TA
A7FL7	119-3580-00			FILTER,EMI:	TK2058	ZJSR-5101-102TA
A7FL8	119-3580-00			FILTER,EMI:	TK2058	ZJSR-5101-102TA
A7FL9	119-3580-00			FILTER,EMI:	TK2058	ZJSR-5101-102TA
A7J2	131-3926-00			CONN,DSUB:	80009	131-3926-00
A7W1	174-2461-00			CA ASSY,SP,ELEC:10,28 AWG,17.0 L,RBN	80009	174-2461-00
A8	119-4809-00			DISPLAY MOD:LCD;320 X 240,DOT MATRIX NTNG AREA	TK0IU	DMC20261ANY-LY-
B100	119-4270-00			FAN,TUBEAXIAL:12 VDC,2.6W,0.22A,4200 RPM,32DB, 16.6CFM,60X60MM,25MMTHICK,W/288MM LEADS&SLEEVE,W/ CONNECT,FBA TYPE	2W944	612
J100	131-3207-00			CONN,RCPT,ELEC:MALE,3 CONTACT	82389	D3M
	175-9542-00			*ATTACHED PARTS* CA ASSY,SP,ELEC:3,26 AWG,4.75 L,MULTI COND	TK1386	ORDER BY DESC

Replaceable electrical parts list (Cont.)

Component number	Tektronix part number	Serial no. effective	Serial no. discont'd	Name & description	Mfr. code	Mfr. part number
	211-0038-00			SCREW,MACHINE:4-40 X 0.312,FLH,100 DEG,STL (QUANTITY 2)	TK0435	ORDER BY DESC
				END ATTACHED PARTS		
J200	131-3207-00			CONN,RCPT,ELEC:MALE,3 CONTACT	82389	D3M
				ATTACHED PARTS		
	175-9542-00			CA ASSY,SP,ELEC:3,26 AWG,4.75 L,MULTI COND	TK1386	ORDER BY DESC
	211-0038-00			SCREW,MACHINE:4-40 X 0.312,FLH,100 DEG,STL (QUANTITY 2)	TK0435	ORDER BY DESC
				END ATTACHED PARTS		
W1	174-1495-00			CA ASSY,SP,ELEC:20,28 AWG,3.0 L,RIBBONSAFETY CONTROLLED (CONNECTED @ A2J1 & A3J1)	TK1547	174-1495-00
W2	174-1495-00			CA ASSY,SP,ELEC:20,28 AWG,3.0 L,RIBBONSAFETY CONTROLLED (CONNECTED @ A2J2 & A3J2)	TK1547	174-1495-00
W3	174-0034-00			CA ASSY,SP,ELEC:28 AWG,3.0 L,RIBBON,2X17 X 2X17 0.1 CTR BOX (CONNECTED @ A2J3 & A4J160)	TK1547	ORDER BY DESC
W4	174-3306-00			CABLE ASSY:RIBBON;IDC,14,28 AWG,7.5 L,2X7, 0.1 CTR,RCPT,NON PLZ X2X7,0.1 CTR,PCB (CONNECTED @ A2J11 & DISPLAY MODULE)	TK2469	174-3306-00
W5	174-2576-00			CA,ASSY RF:COAXIAL:RFD,75 OHM,18.25 L,9-2, BNC,FRONT MT,JACK X RTANG,50 OHM SMB (CONNECTED @ A2J17 & "SERIAL BLACK" REAR)	80009	174257600
W6	174-2576-00			CA,ASSY RF:COAXIAL:RFD,75 OHM,18.25 L,9-2, BNC,FRONT MT,JACK X RTANG,50 OHM SMB (CONNECTED @ A2J18 & "SERIAL BARS" REAR)	80009	174257600
W7	175-9861-00			CABLE ASSY,RF:75 OHM COAX,4.797 L,9-3 (CONNECTED @ A3J7 TO "SERIAL AUDIO 1+2" REREAR PANEL)	80009	175986100
W8	175-9861-00			CABLE ASSY,RF:75 OHM COAX,4.797 L,9-3 (CONNECTED @ A3J8 TO "SERIAL AUDIO 3+4"	80009	175986100
W9	174-1495-00			CA ASSY,SP,ELEC:20,28 AWG,3.0 L,RIBBONSAFETY CONTROLLED (CONNECTED @ A2J4 & A5J1,OPTION 01 ONLY)	TK1547	174-1495-00
W10	174-1495-00			CA ASSY,SP,ELEC:20,28 AWG,3.0 L,RIBBONSAFETY CONTROLLED (CONNECTED @ A2J5 & A6J1,OPTION 02 ONLY)	TK1547	174-1495-00
W11	174-2576-00			CA,ASSY RF:COAXIAL:RFD,75 OHM,18.25 L,9-2, BNC,FRONT MT,JACK X RTANG,50 OHM SMB (CONNECTED @ A6J5 TO "SERIAL SIGNAL" REAR, OPTION 02 ONLY)	80009	174257600
W12	174-2576-00			CA,ASSY RF:COAXIAL:RFD,75 OHM,18.25 L,9-2, BNC,FRONT MT,JACK X RTANG,50 OHM SMB (CONNECTED @ A6J6 TO "SERIAL SIGNAL" REAR, OPTION 02 ONLY)	80009	174257600

Diagrams/Circuit Board Illustrations

Symbols

Graphic symbols and class designation letters are based on ANSI Standard Y32.2–1975.

Logic symbology is based on ANSI Y32.14–1973 in terms of positive logic. Logic symbols depict the logic function performed and may differ from the manufacturer’s data.

Overline, parenthesis, or leading slash indicate a low asserting state.

Example: ID CONTROL, (ID CONTROL), or /ID CONTROL.

Abbreviations are based on ANSI Y1.1–1972.

Other ANSI standards that are used in the preparation of diagrams by Tektronix, Inc. are:

- Y14.15, 1966 -- Drafting Practices.
- Y14.2, 1973 -- Line Conventions and Lettering.
- Y10.5, 1968 -- Letter Symbols for Quantities Used in Electrical Science and Electrical Engineering.

American National Standard Institute
1430 Broadway, New York, New York 10018

Component Values

Electrical components shown on the diagrams are in the following units unless noted otherwise:

Capacitors: Values one or greater are in picofarads (pF).
Values less than one are in microfarads (μ F).

Resistors = Ohms (Ω).

The following information and special symbols may appear in this manual.

Assembly Numbers

Each assembly in the instrument is assigned an assembly number (e.g., A20). The assembly number appears on the diagram (in circuit board outline), circuit board illustration title, and lookup table for the schematic diagram.

The Replaceable Electrical Parts List is arranged by assembly number in numerical sequence; the components are listed by component number. Example:

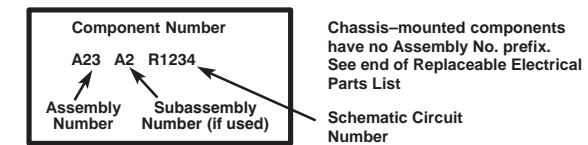

Grid Coordinates

The schematic diagram and circuit board component location illustration have grids. A lookup table with the grid coordinates is provided for ease of locating the component. Only the components illustrated on the facing diagram are listed in the lookup table.

When more than one schematic diagram is used to illustrate the circuitry on a circuit board, the circuit board illustration will only appear opposite the first diagram; the lookup table will list the diagram number of other diagrams that the other circuitry appears on.

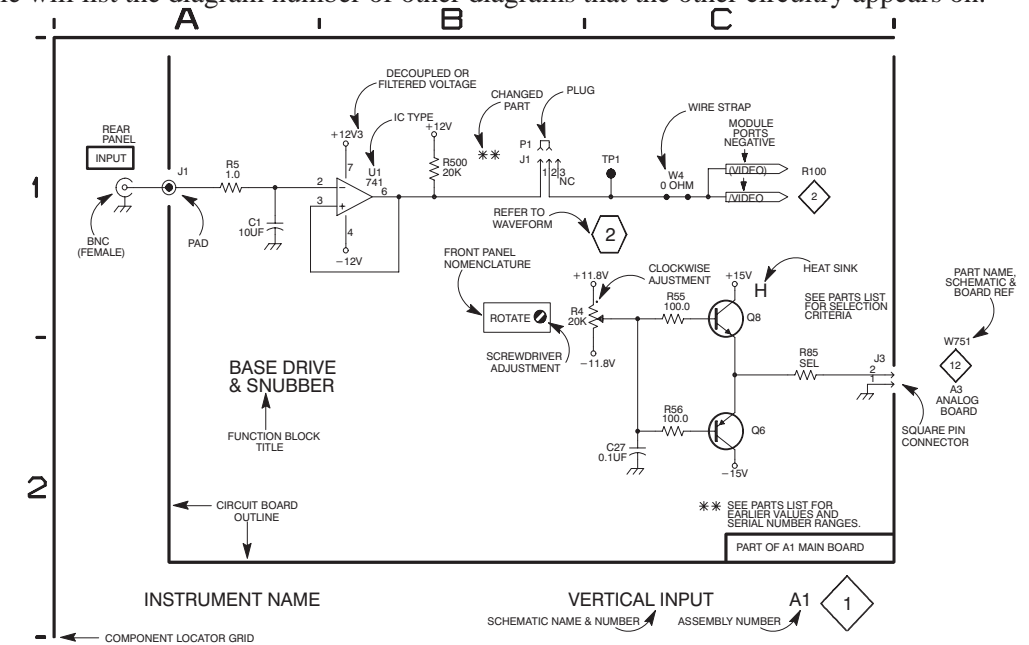

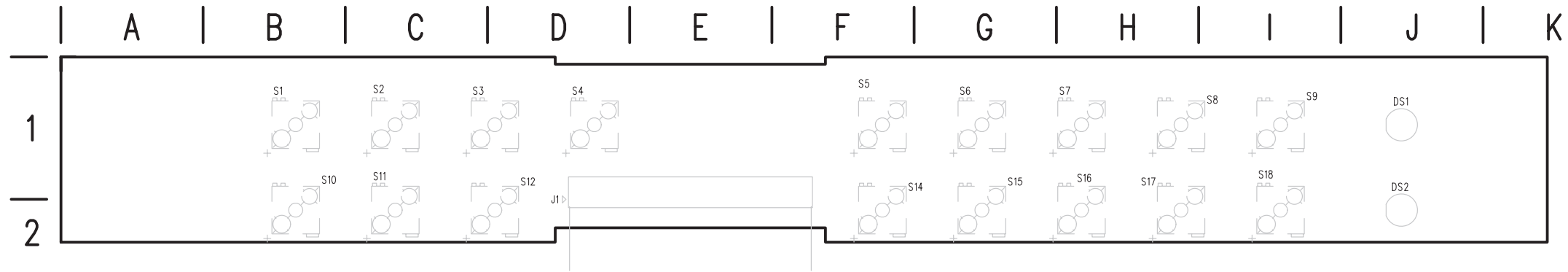

 **Static Sensitive Devices**
See Maintenance Section

A1 Front Panel Board

A1 Front Panel Board and Diagram <1> Component Locator

1/2			1/2			1/2			1/2			1/2			1/2			1/2					
DS1	G2	J1	S1A	A2	B1	S3B	B2	C1	S6A	E2	G1	S8B	E2	I1	S11A	B4	C1	S14B	D3	F1	S17A	E4	H1
DS2	G3	J1	S1B	A2	B1	S4A	C2	D1	S6B	E2	G1	S9A	F2	I1	S11B	B3	C1	S15A	E4	G1	S17B	E3	H1
			S2A	B2	C1	S4B	C2	D1	S7A	E2	H1	S9B	F2	I1	S12A	B4	D1	S15B	E3	G1	S18A	F4	I1
J1	H2	D2	S2B	B2	C1	S5A	D2	F1	S7B	E2	H1	S10A	A4	B1	S12B	B3	D1	S16A	E4	H1	S18B	F3	I1
			S3A	B2	C1	S5B	D2	F1	S8A	E2	I1	S10B	A3	B1	S14A	D4	F1	S16B	E3	H1			

A

B

C

D

E

F

G

H

1

2

3

4

5

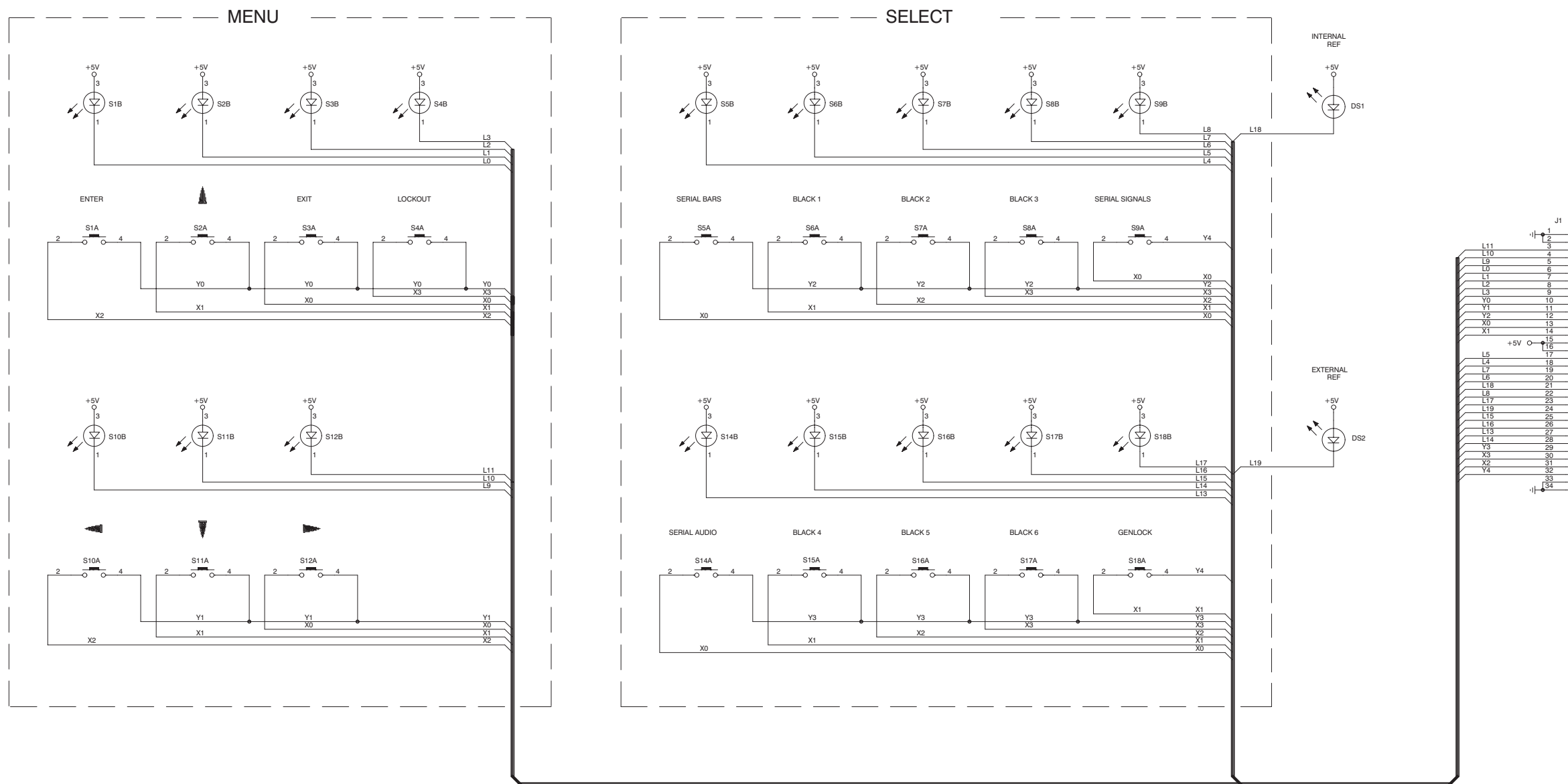

A1 FRONT PANEL BOARD

A | B | C | D | E | F | G | H | I | J | K | L | M | N | O | P

1
2
3
4
5
6
7
8
9

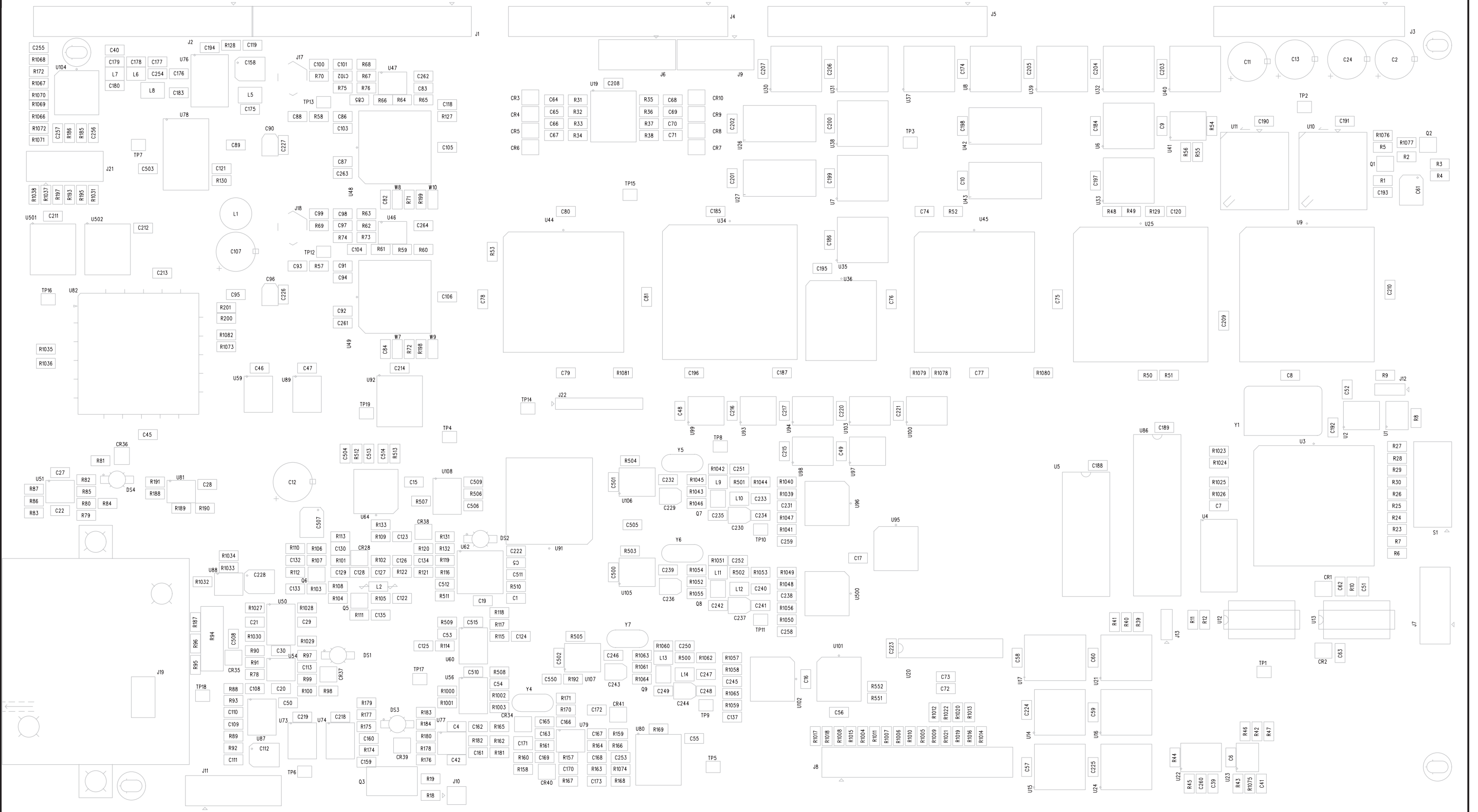

 **Static Sensitive Devices**
See Maintenance Section

A2 Digital Board

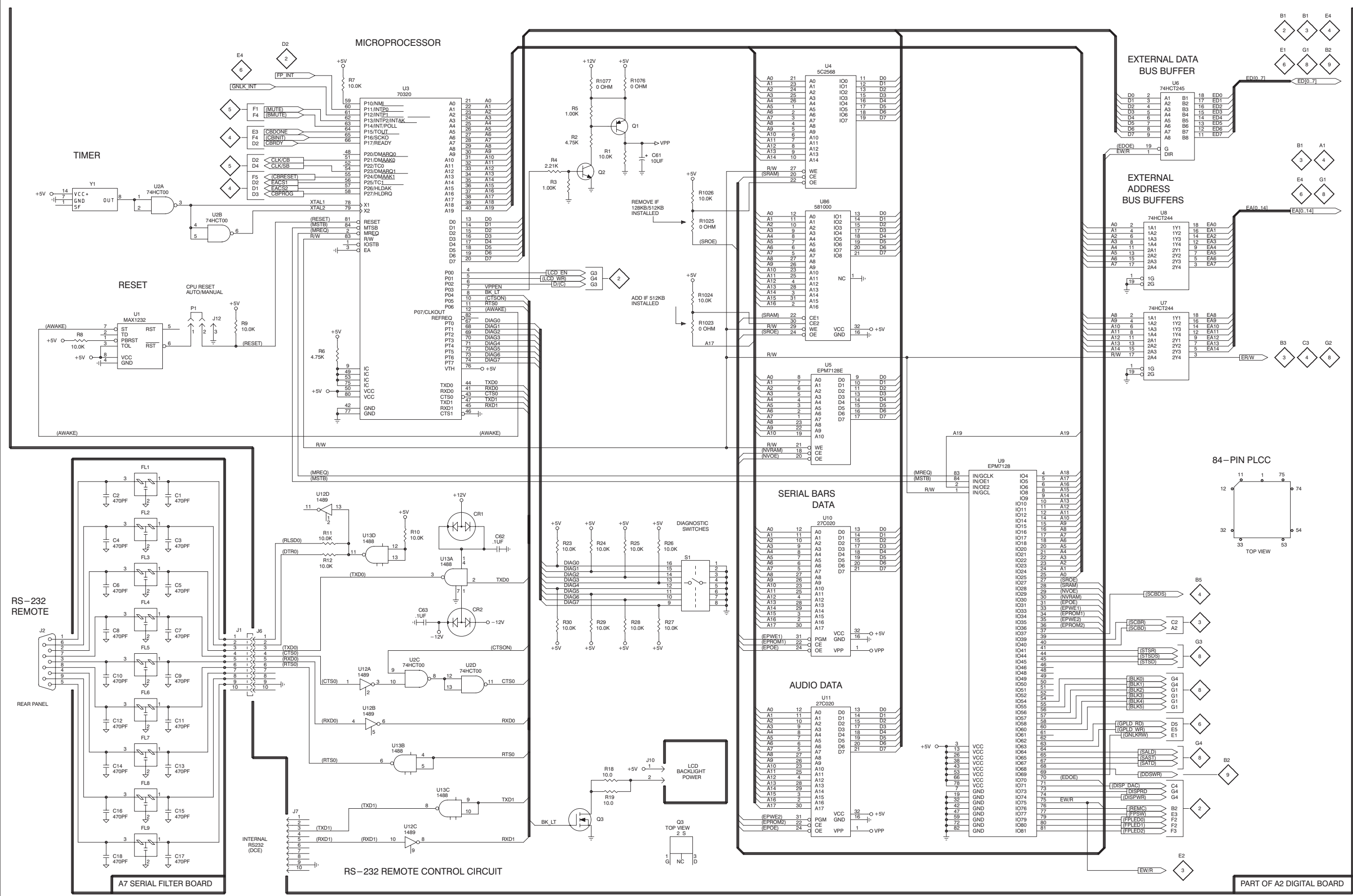

SPG 422 Component Digital Sync Generator

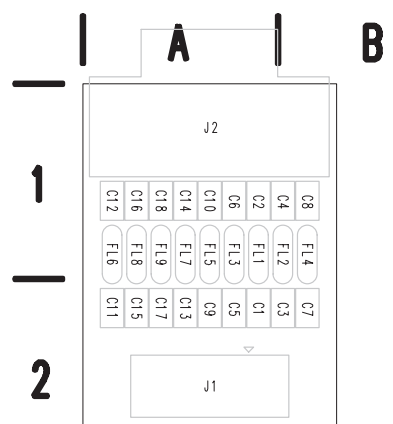

A7 Serial Filter

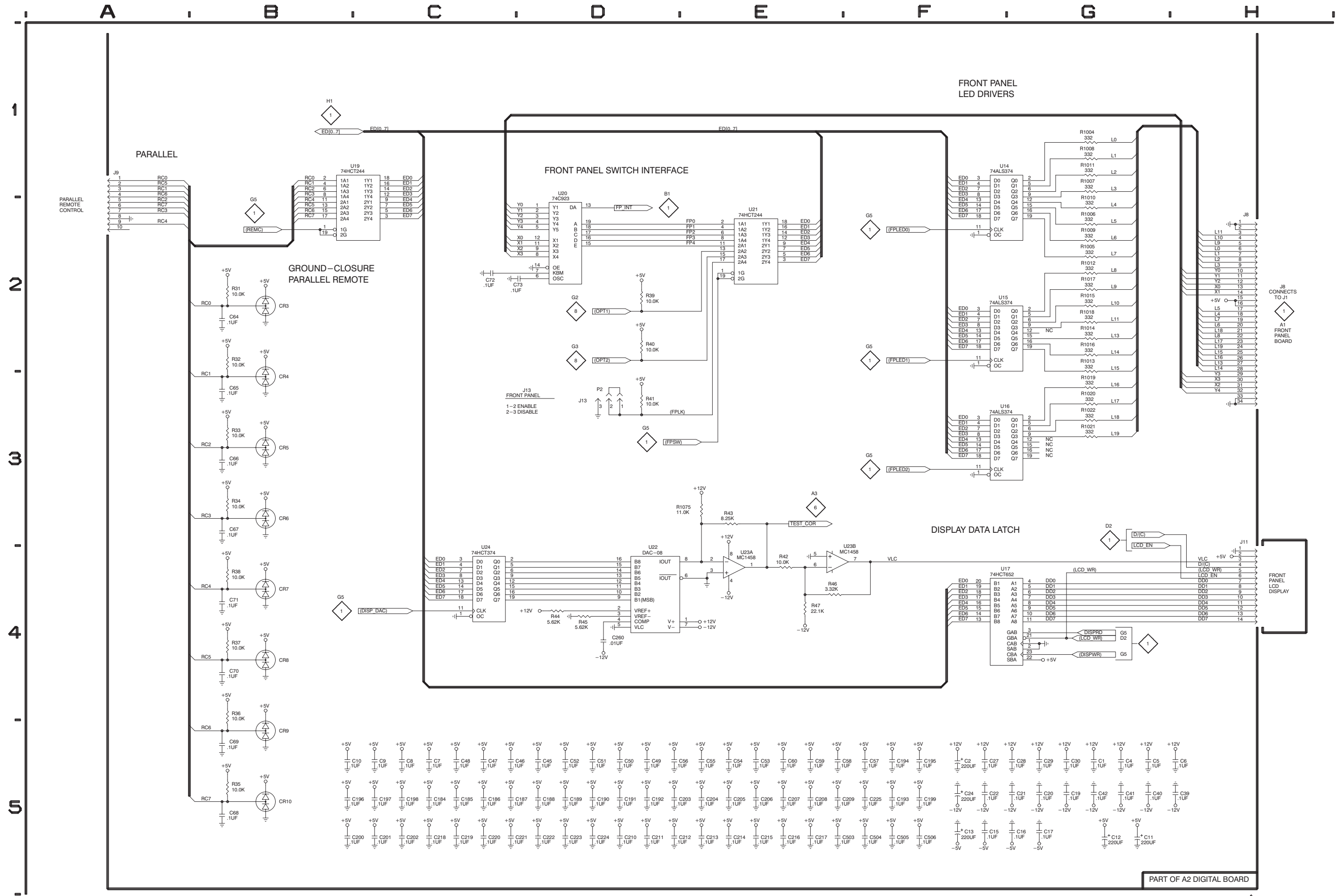

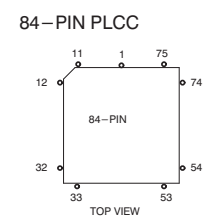
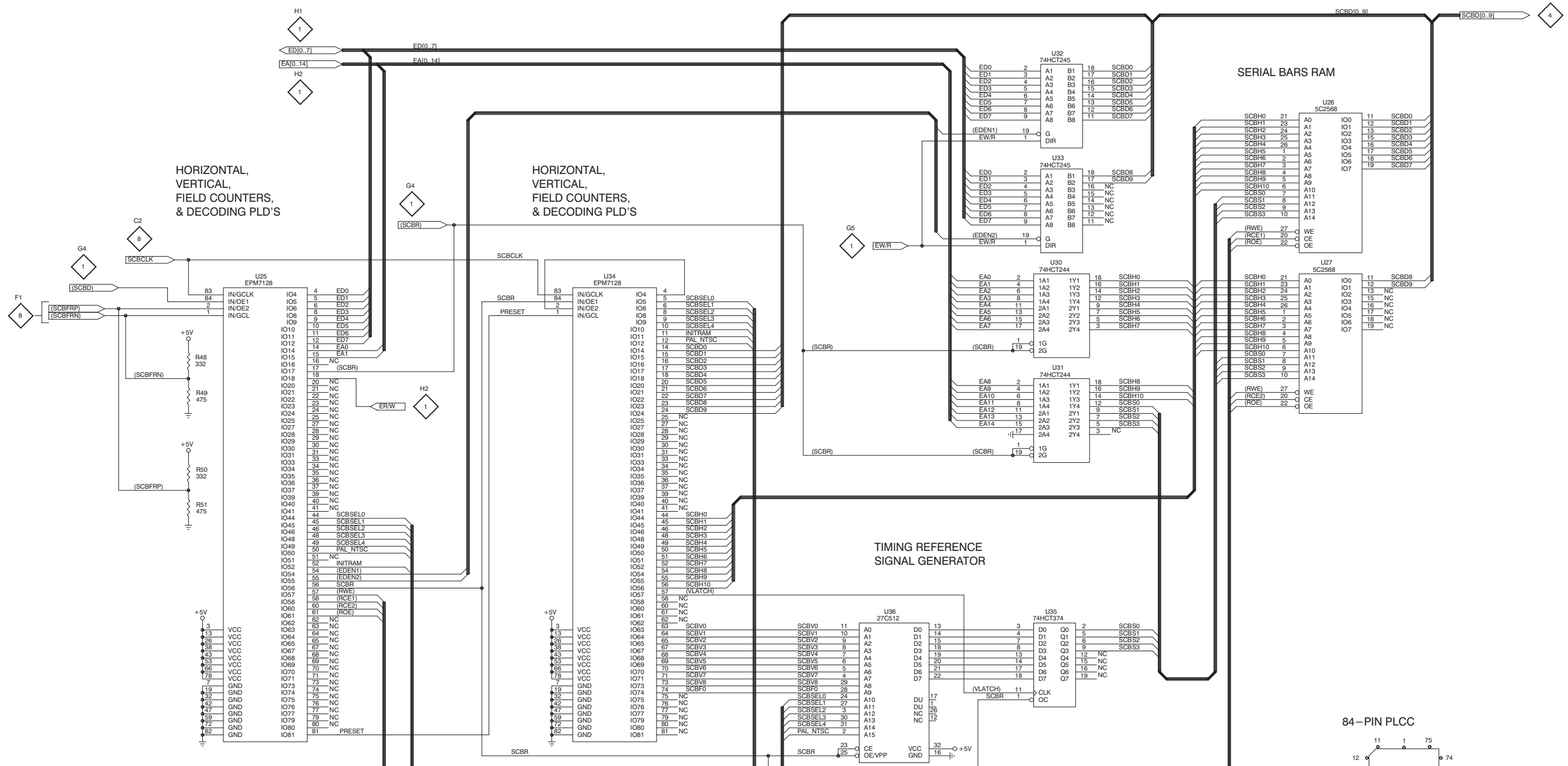

PART OF A2 DIGITAL BOARD

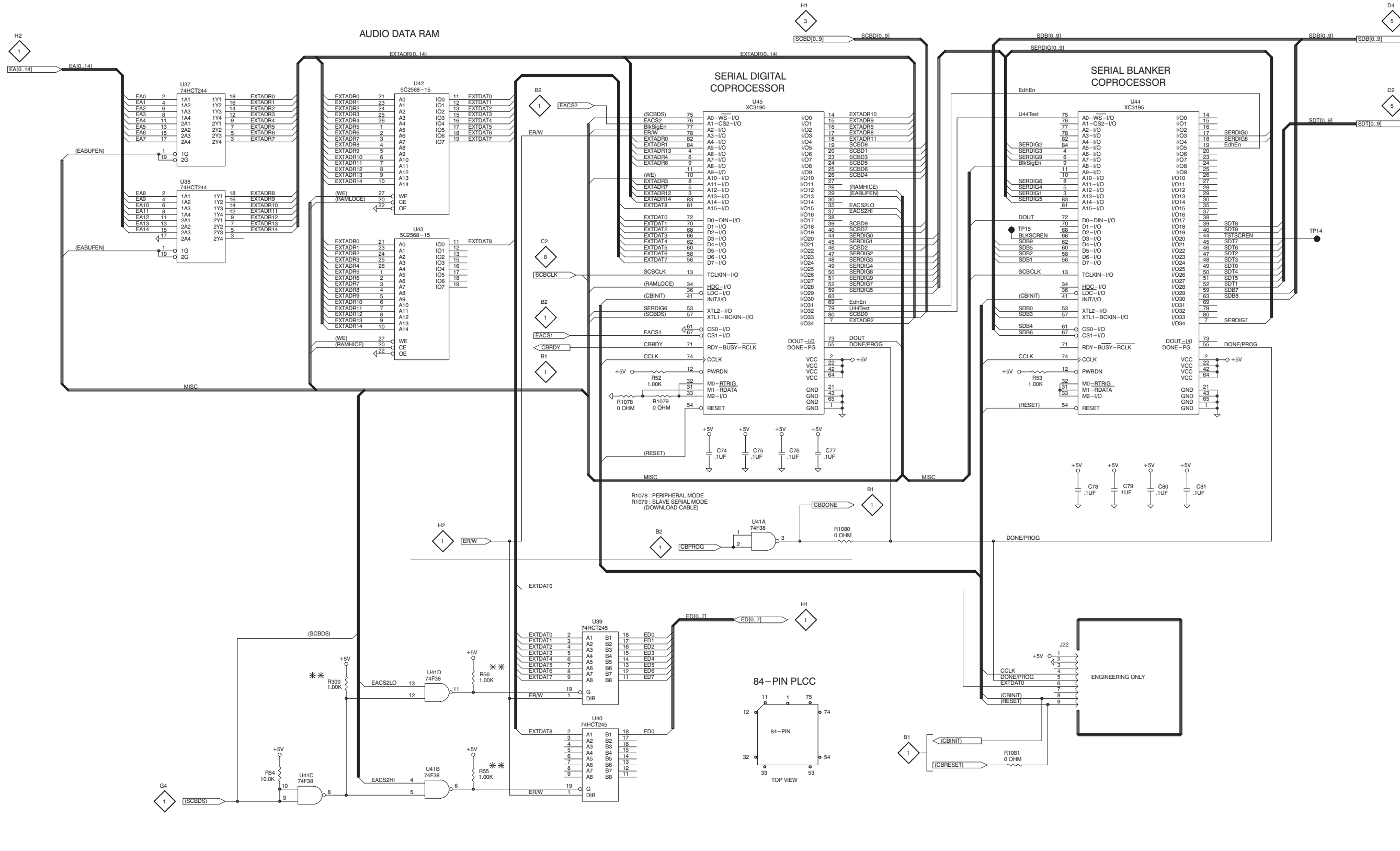

NOTE: ** SEE PARTS LIST FOR EARLIER VALUES AND SERIAL NUMBER RANGES.

PART OF A2 DIGITAL BOARD

1

2

3

4

5

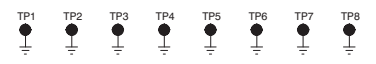
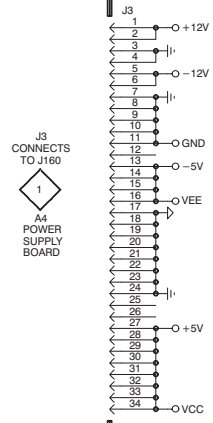

SERIAL BARS OUTPUT SERIALIZER

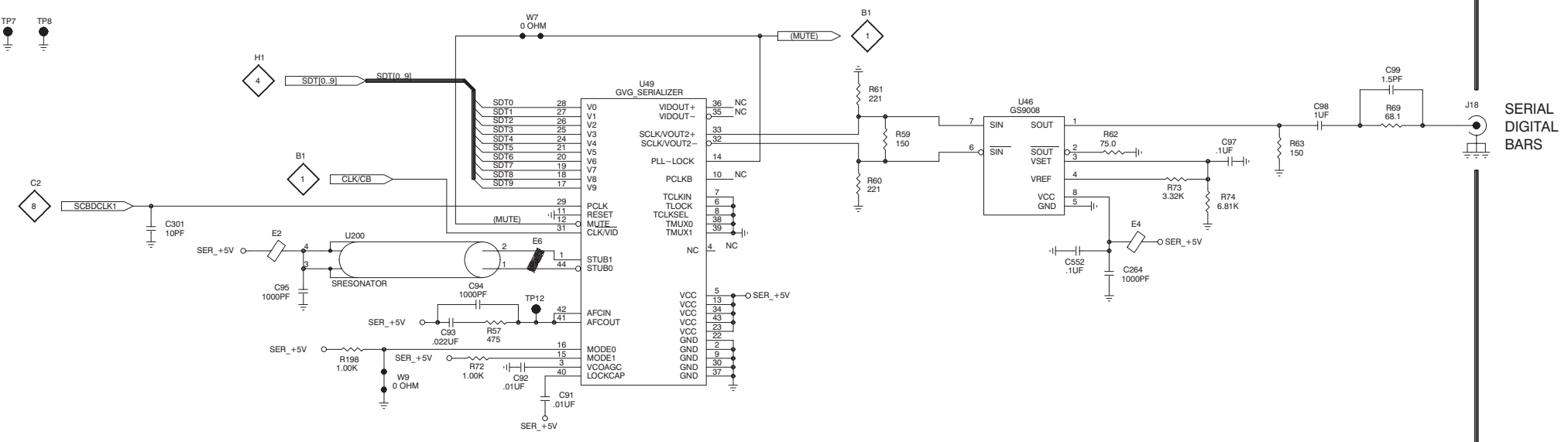

44-PIN PLCC

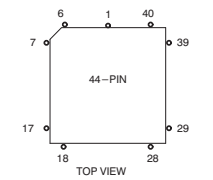

SERIAL BLACK OUTPUT SERIALIZER

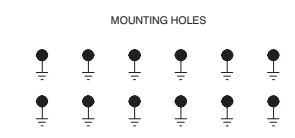
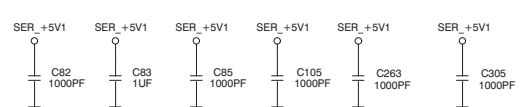
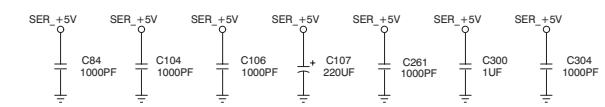
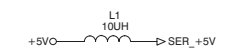
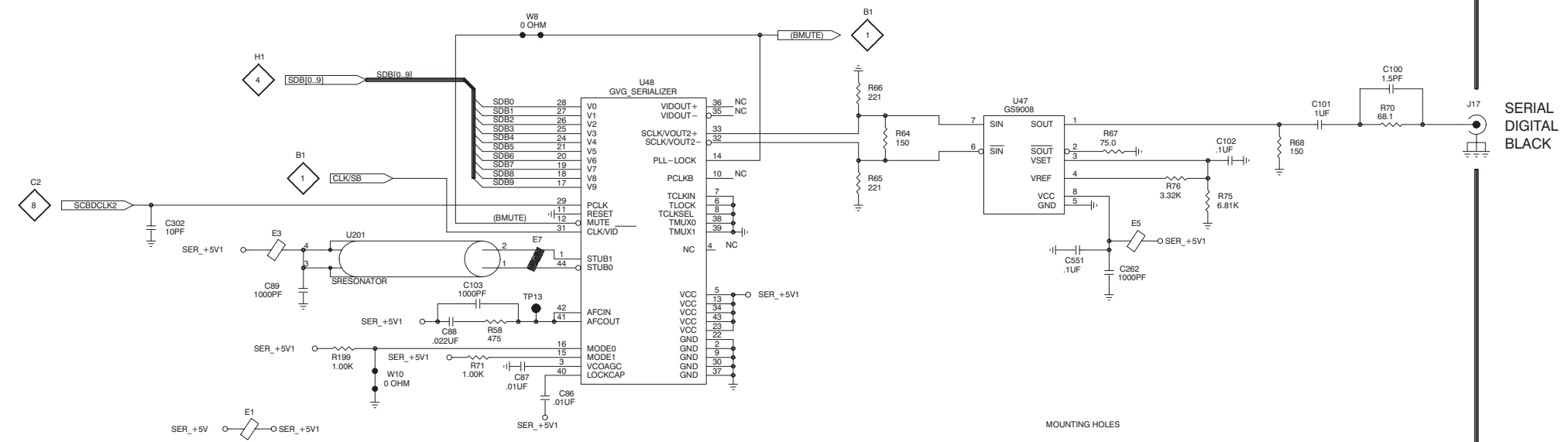

NOTE: * * SEE PARTS LIST FOR EARLIER VALUES AND SERIAL NUMBER RANGES.

PART OF A2 DIGITAL BOARD

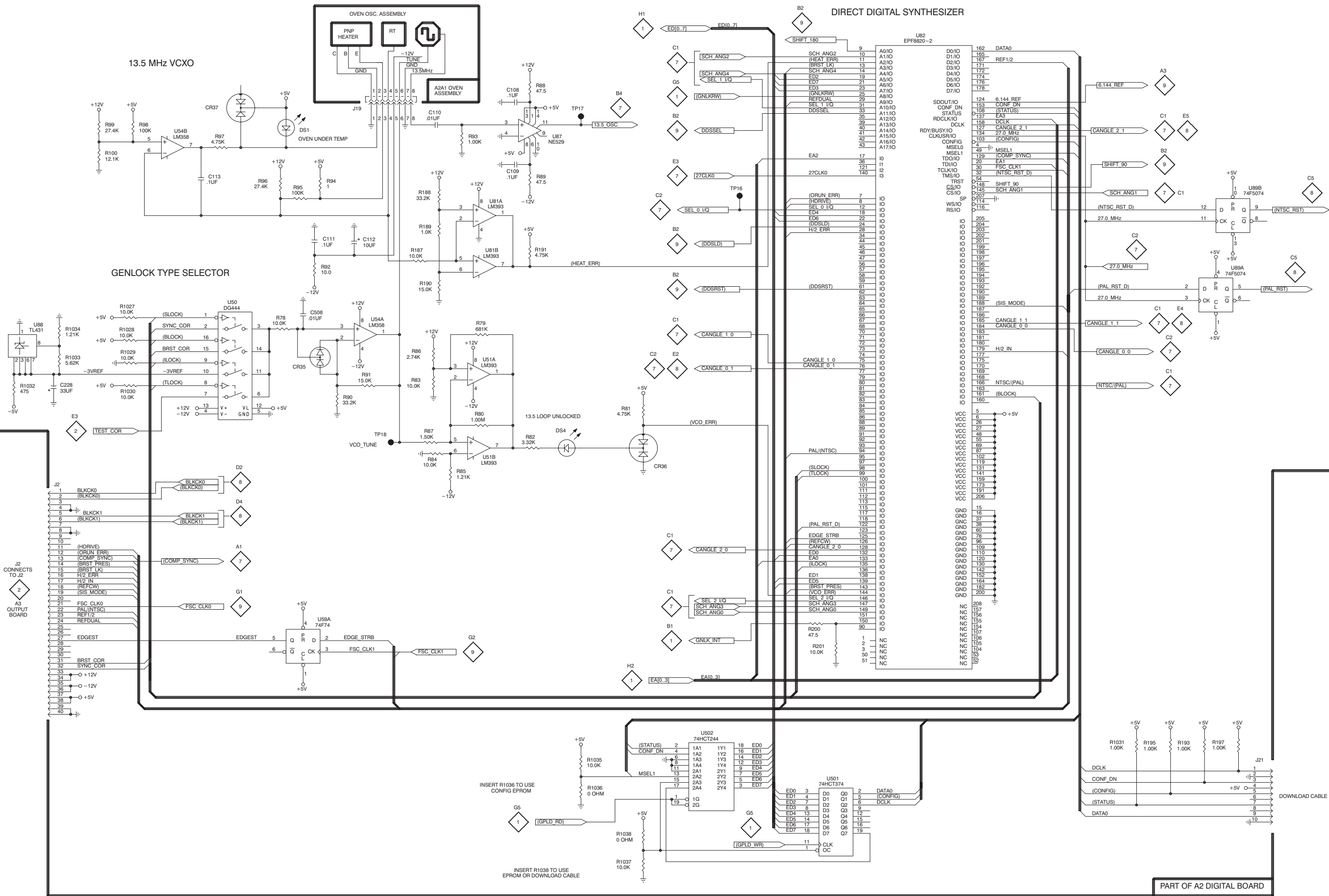

SPG 422 Component Digital Sync Generator

13.5 MHz GENLOCK CONTROL

1
2
3
4
5

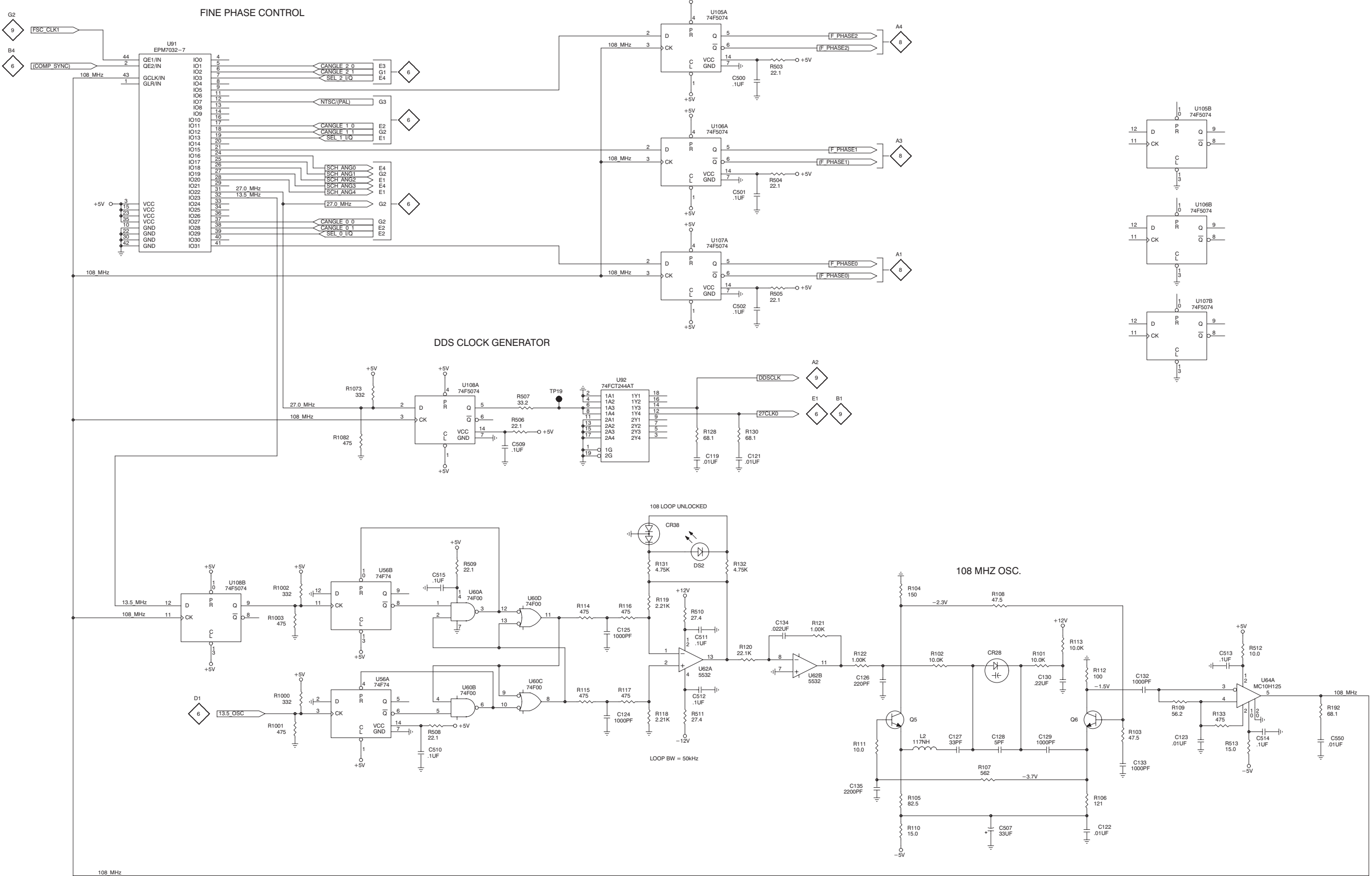

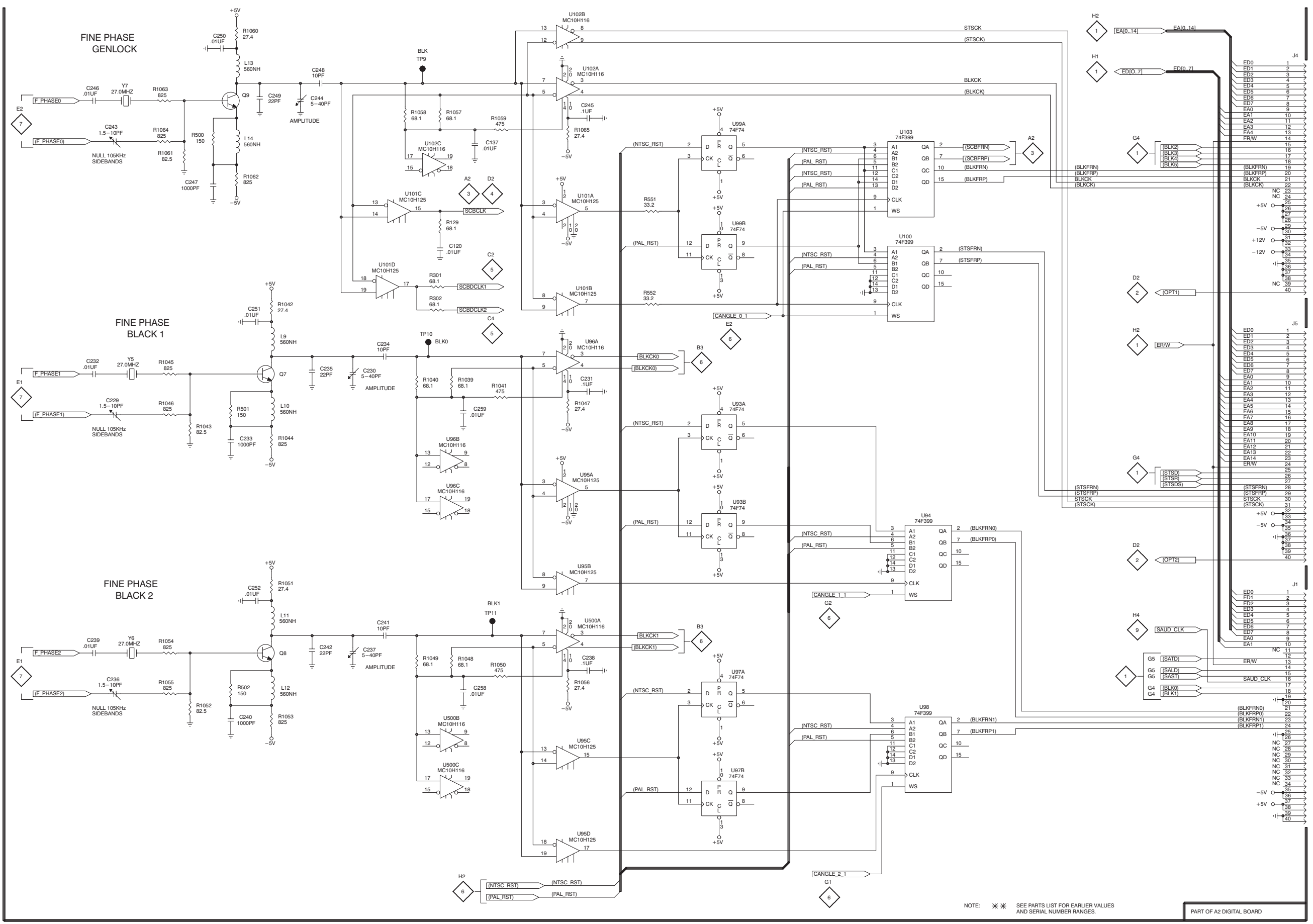

NOTE: ** SEE PARTS LIST FOR EARLIER VALUES AND SERIAL NUMBER RANGES.

PART OF A2 DIGITAL BOARD

1

2

3

4

5

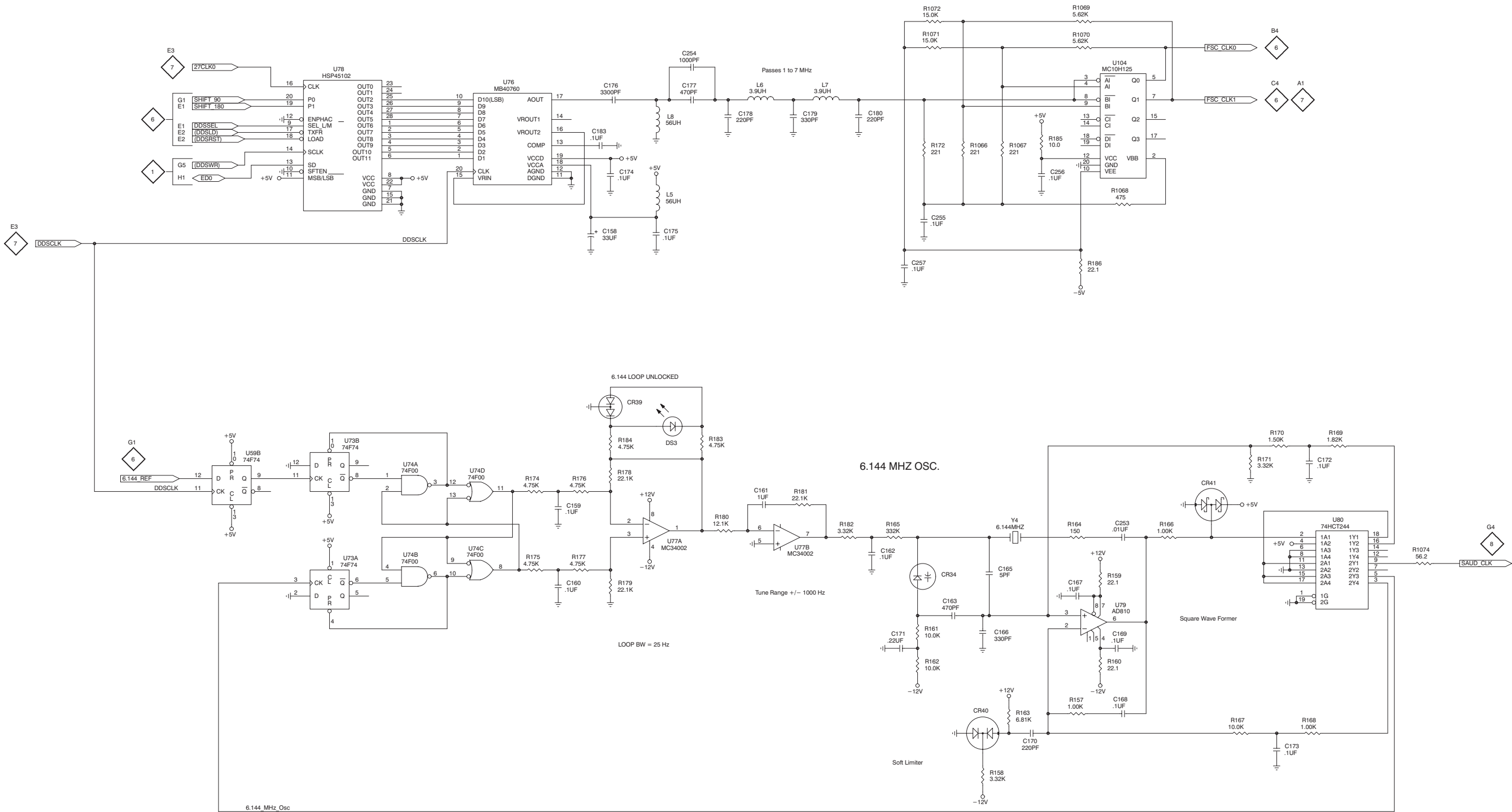

PART OF A2 DIGITAL BOARD

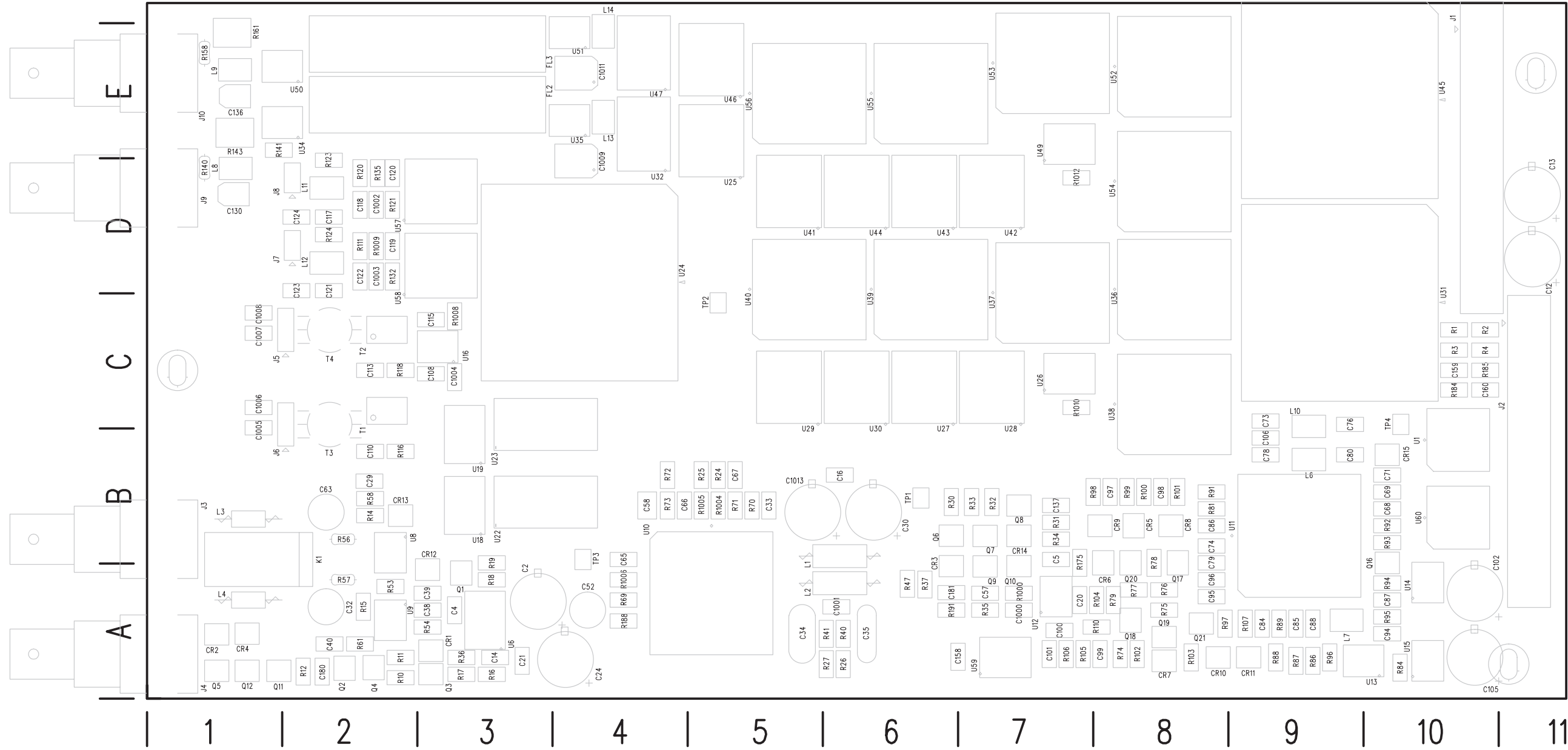

 **Static Sensitive Devices**
See Maintenance Section

A3 Output Board (Front)
(671-3123-02 and above)

1

2

3

4

5

GENLOCK SELECTOR (2:1 MUX)

SYNC STRIPPER

CHROMA FILTER

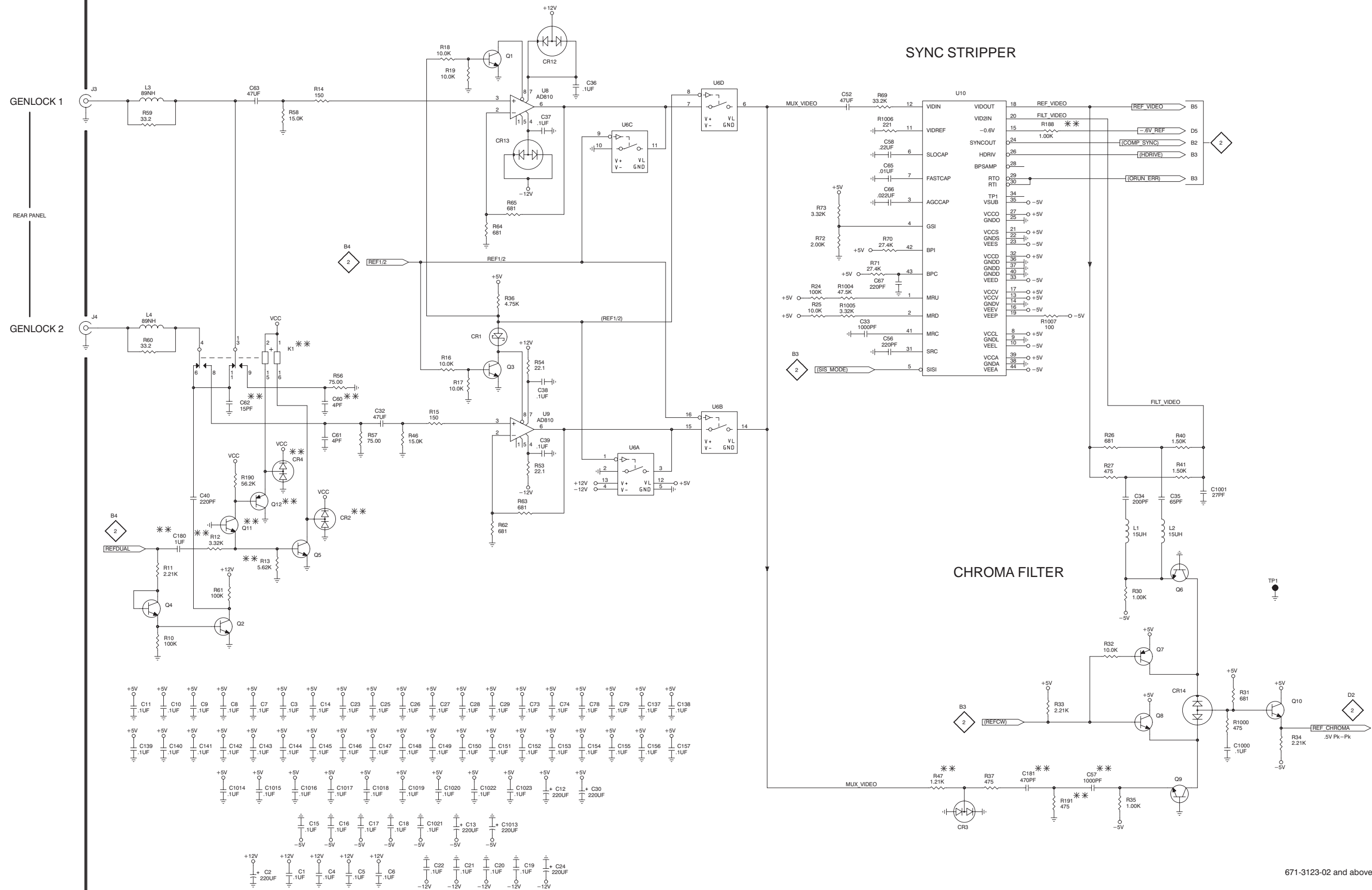

671-3123-02 and above

NOTE: * * * SEE PARTS LIST FOR EARLIER VALUES AND SERIAL NUMBER RANGES.

PART OF A3 OUTPUT BOARD

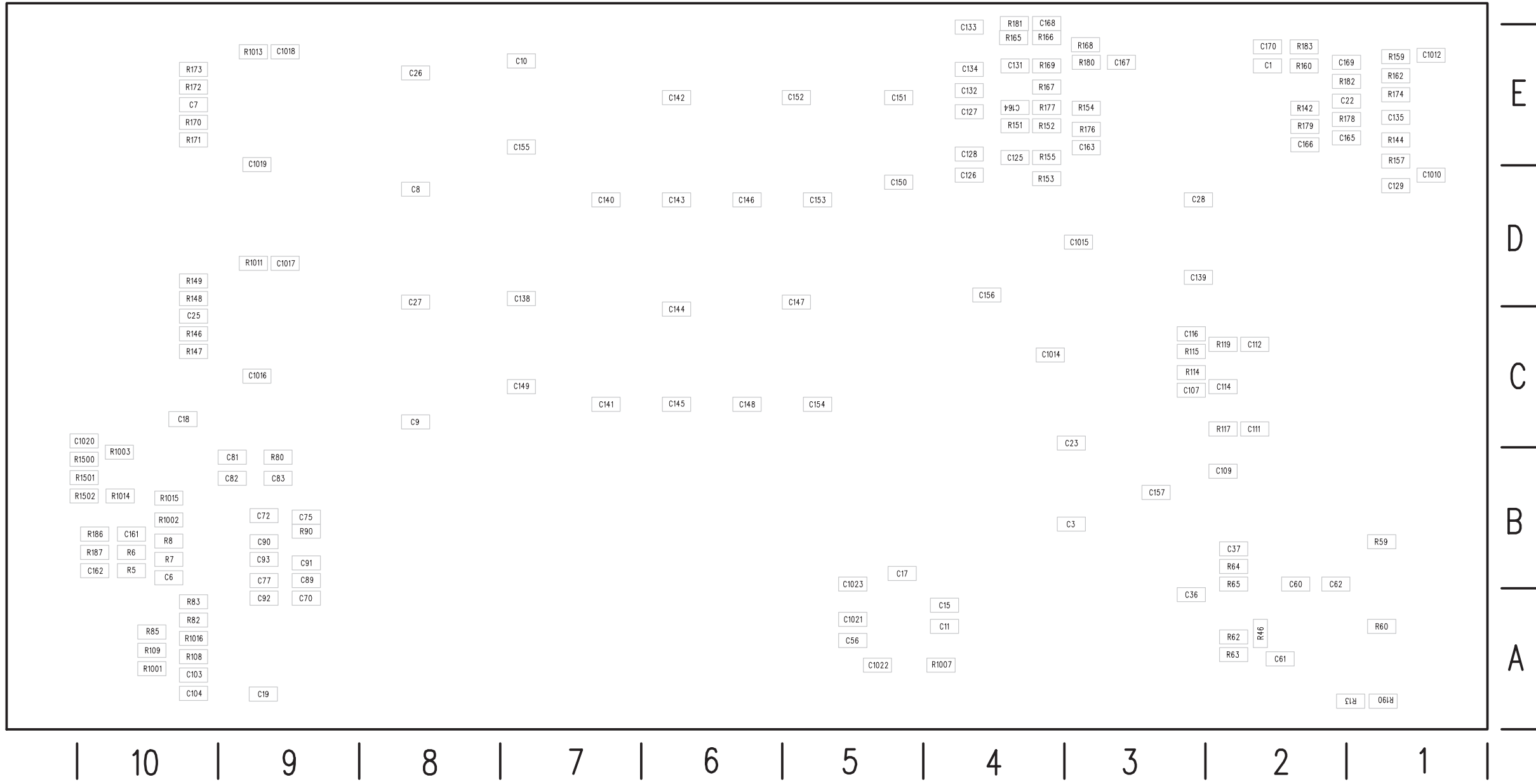

 **Static Sensitive Devices**
See Maintenance Section

A3 Output Board (Back)
(671-3123-02 and above)

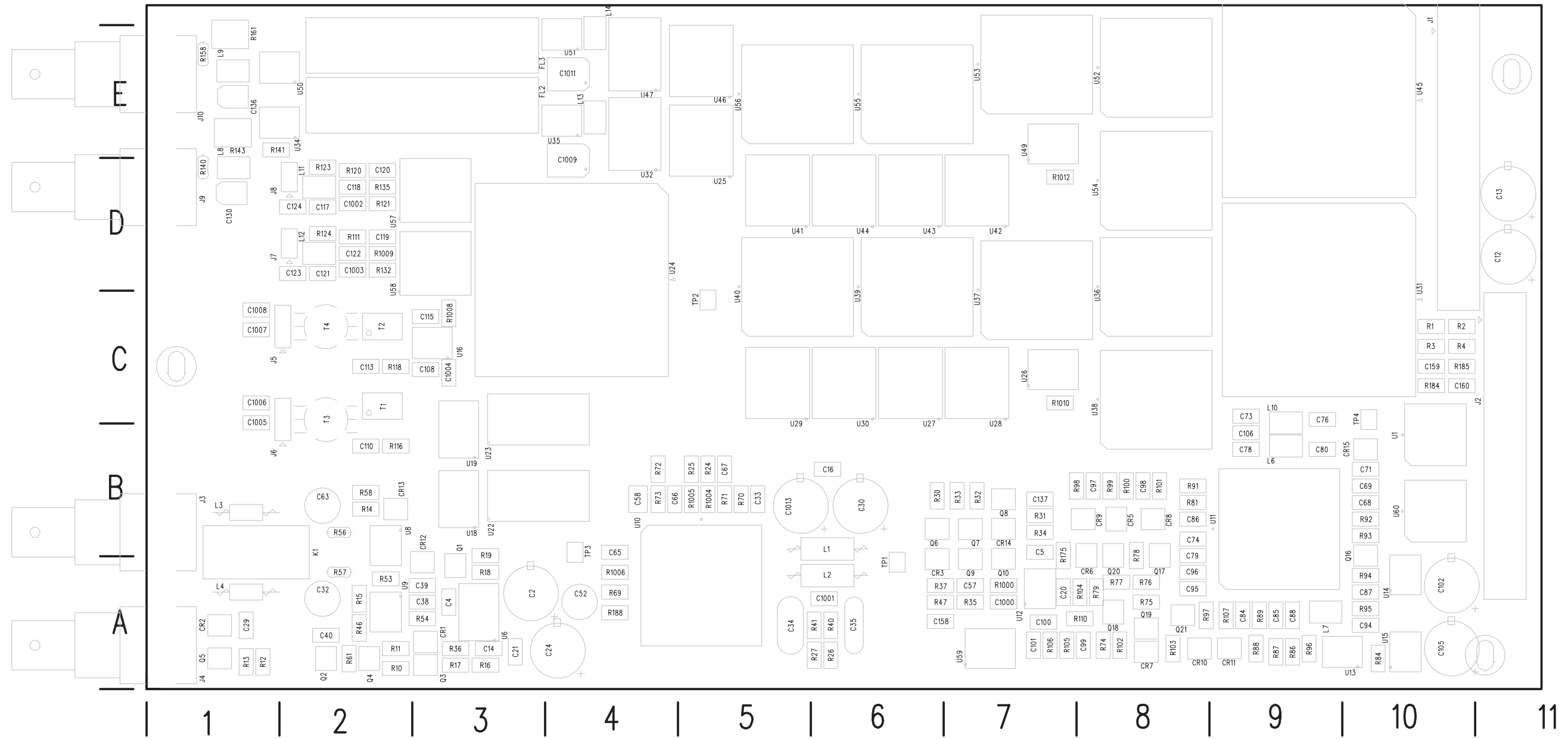

⊗ Static Sensitive Devices
See Maintenance Section

A3 Output Board (Front)
(671-3123-01 and below)

1
2
3
4
5

GENLOCK SELECTOR (2:1 MUX)

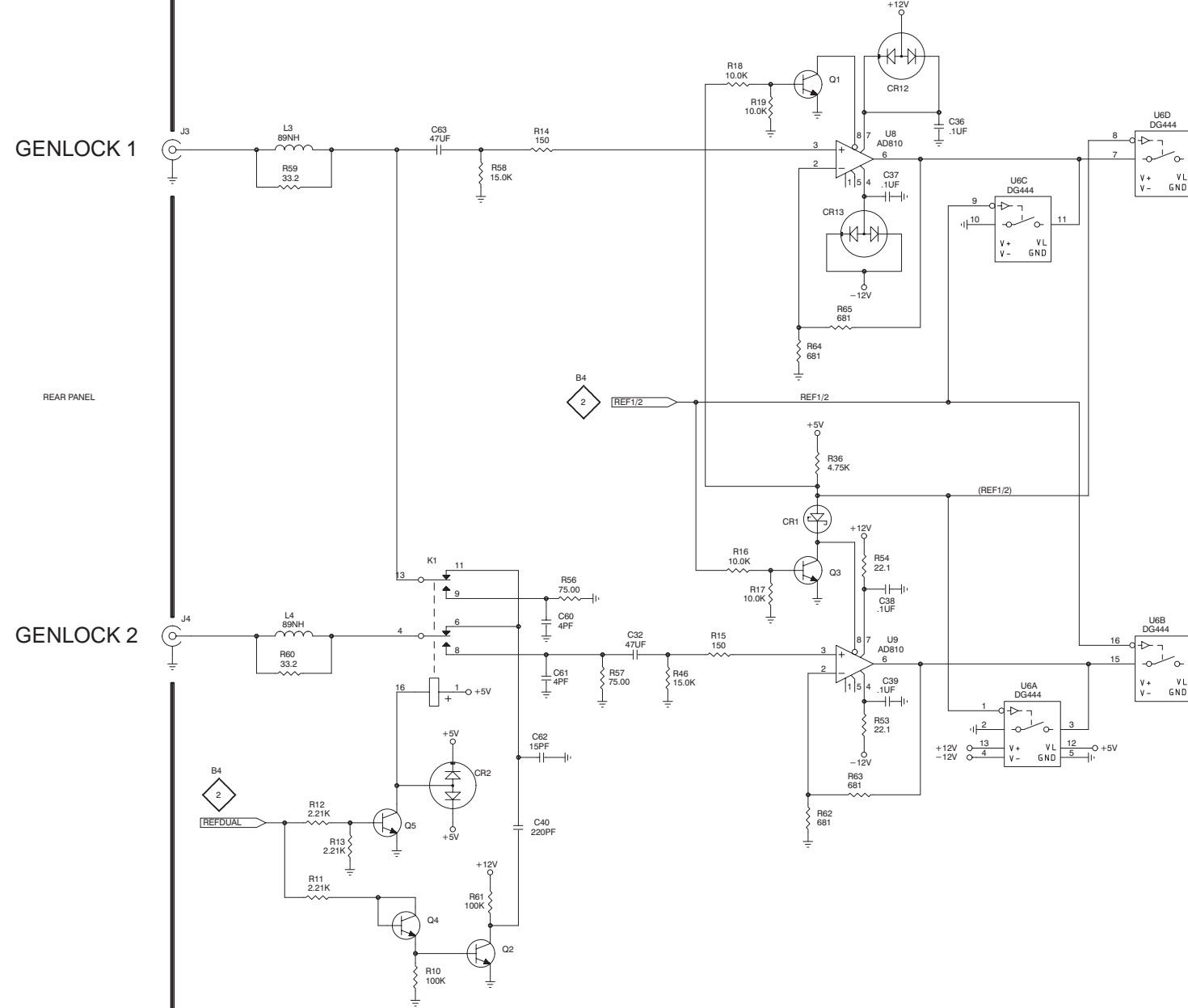

SYNC STRIPPER

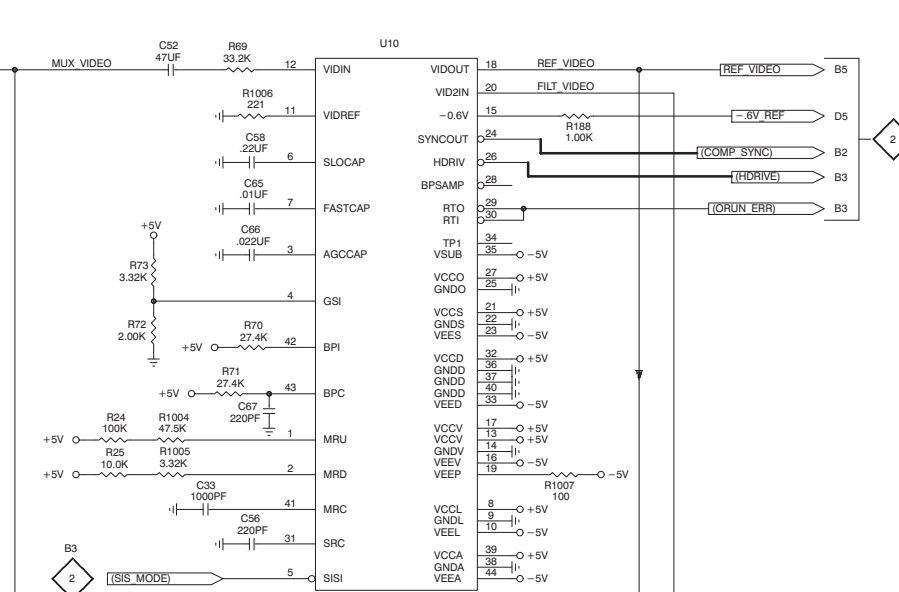

CHROMA FILTER

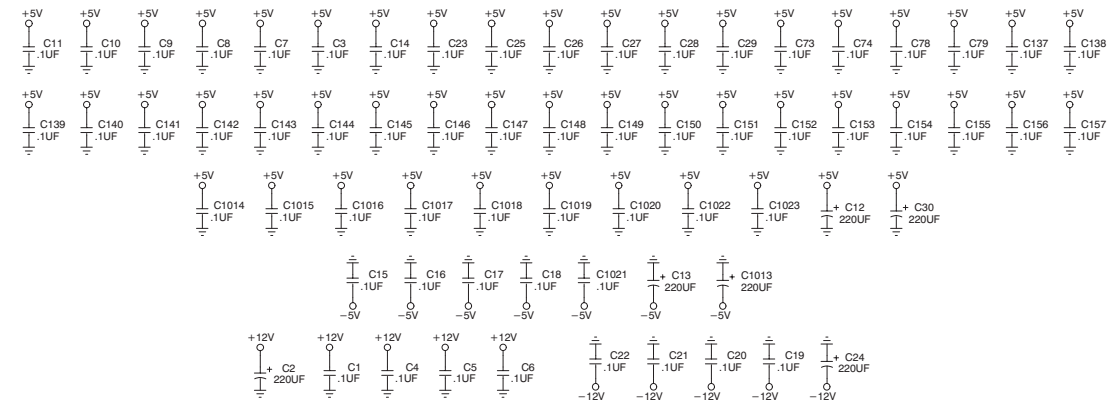
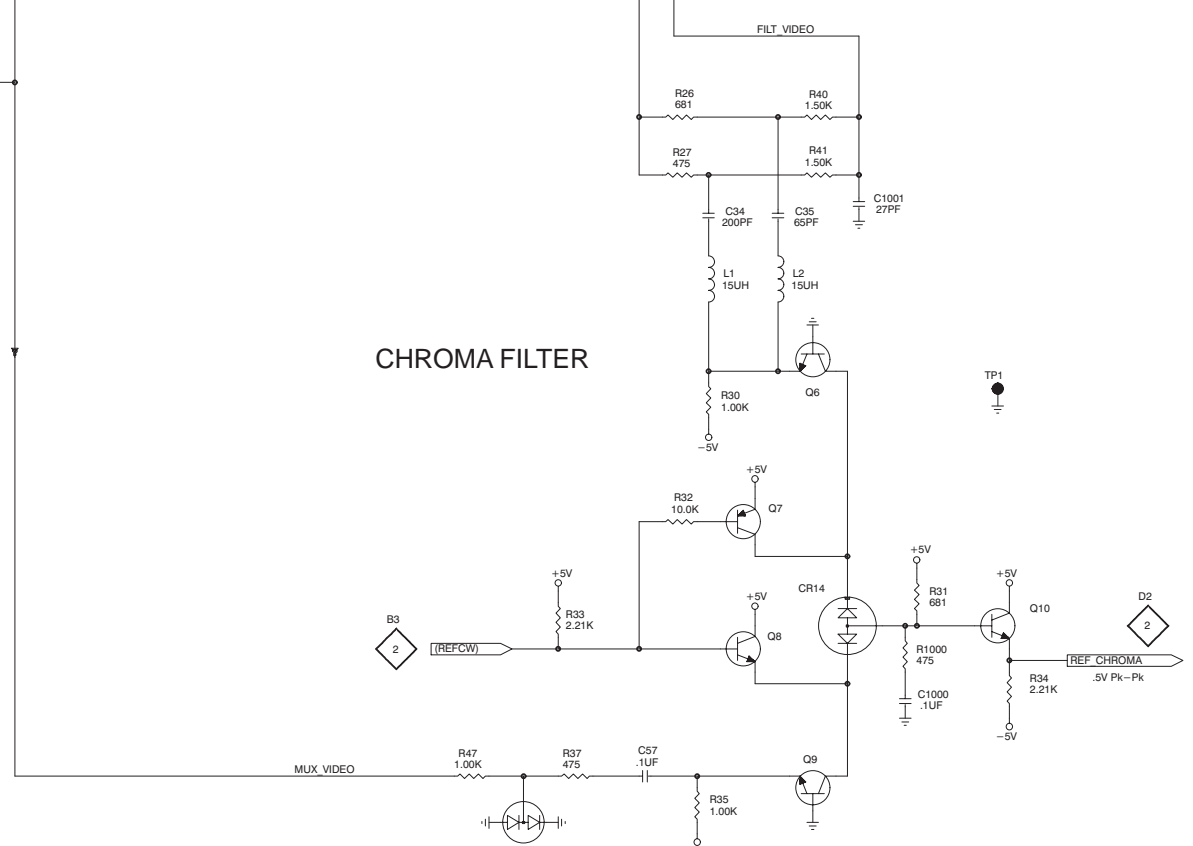

671-3123-01 and below

NOTE: * SEE PARTS LIST FOR EARLIER VALUES AND SERIAL NUMBER RANGES.

PART OF A3 OUTPUT BOARD

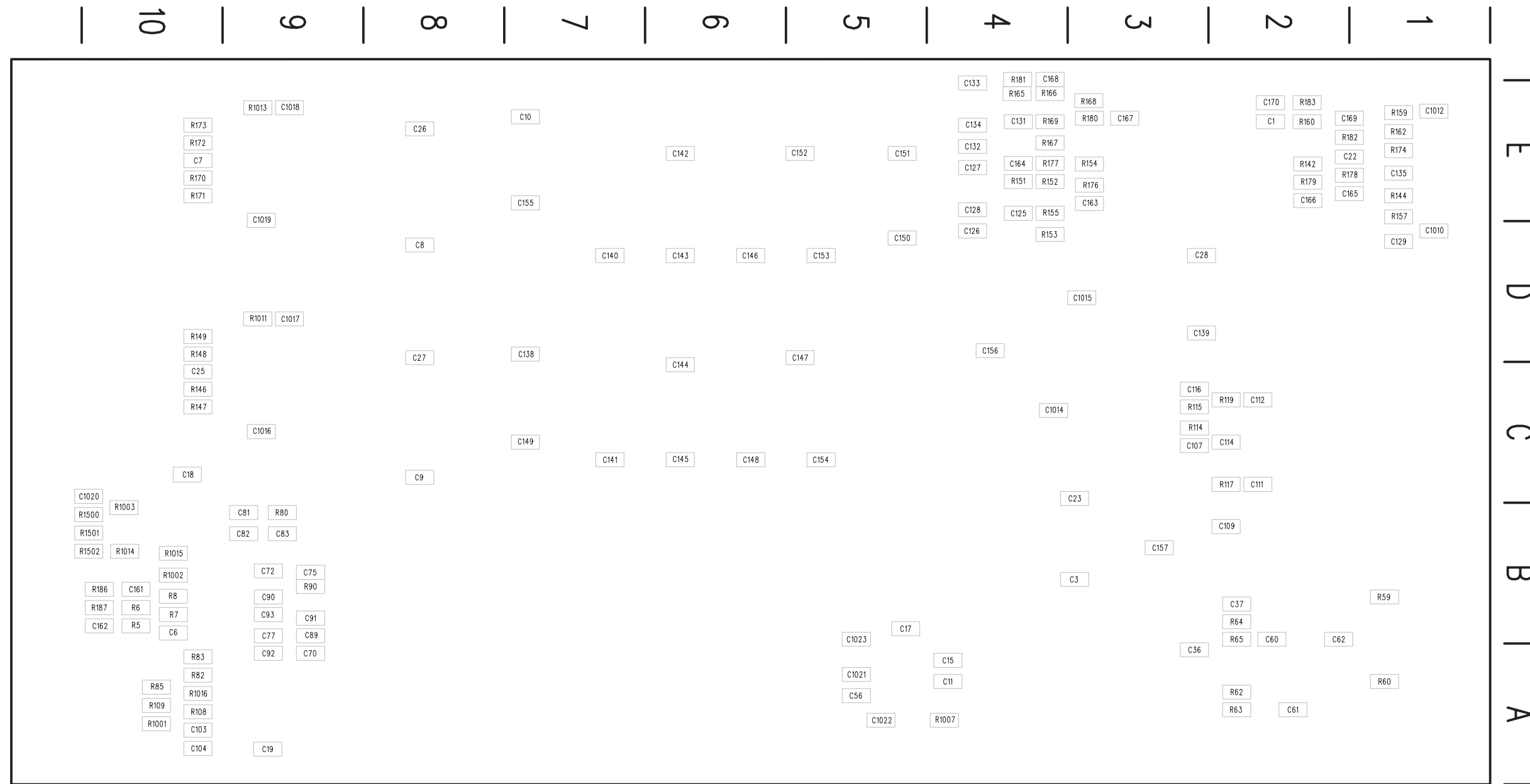

Static Sensitive Devices
 See Maintenance Section

A3 Output Board (Back)
(671-3123-01 and below)

1

2

3

4

5

J2 CONNECTS TO J2 A2 DIGITAL BOARD

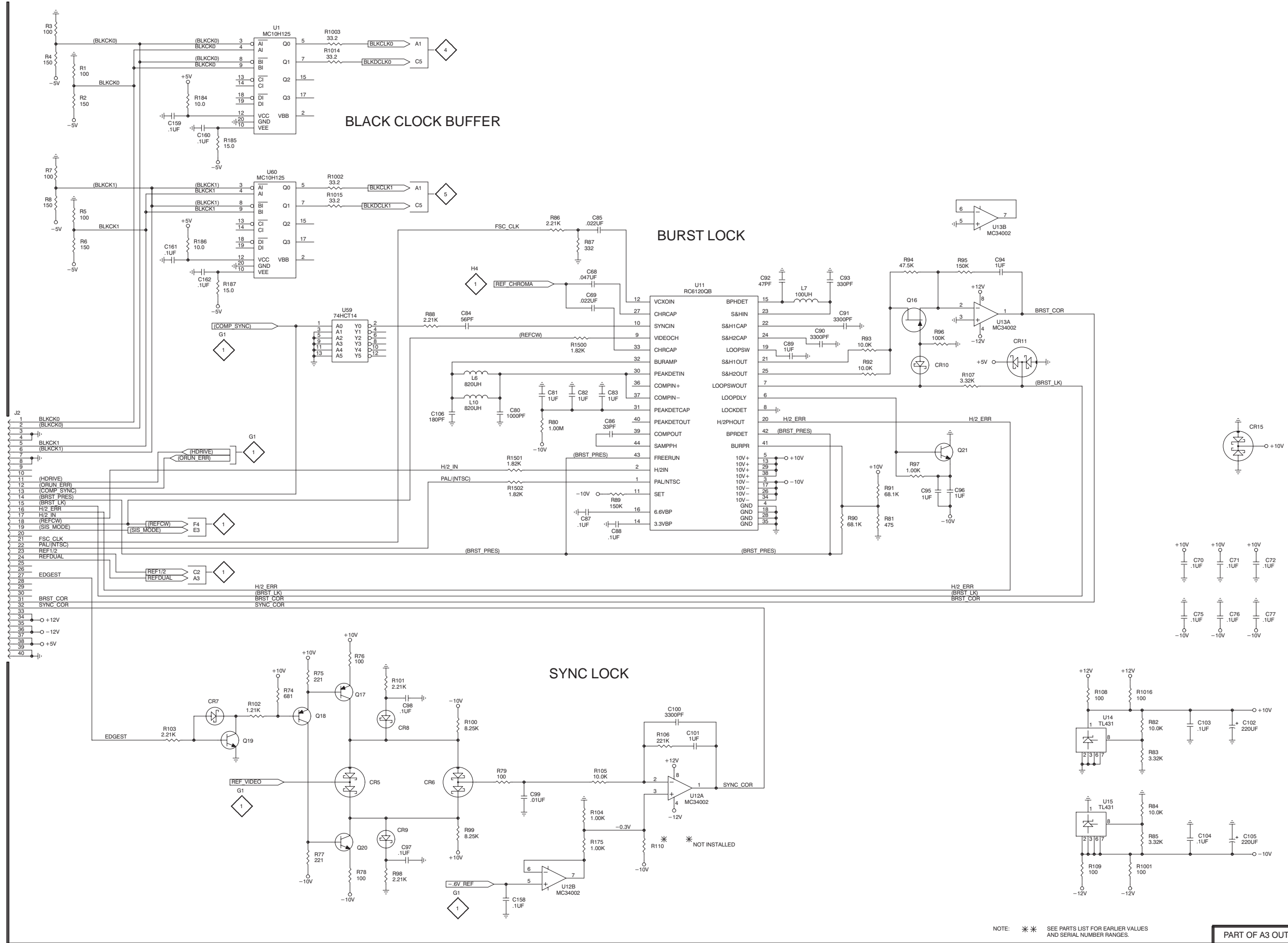

AUDIO GENERATOR

AUDIO PARALLEL TO SERIAL CONVERTERS

AUDIO OUTPUTS

REAR PANEL

SERIAL AUDIO 1 + 2

SERIAL AUDIO 1 + 2

SERIAL AUDIO 3 + 4

SERIAL AUDIO 3 + 4

REAR PANEL

PART OF A3 OUTPUT BOARD

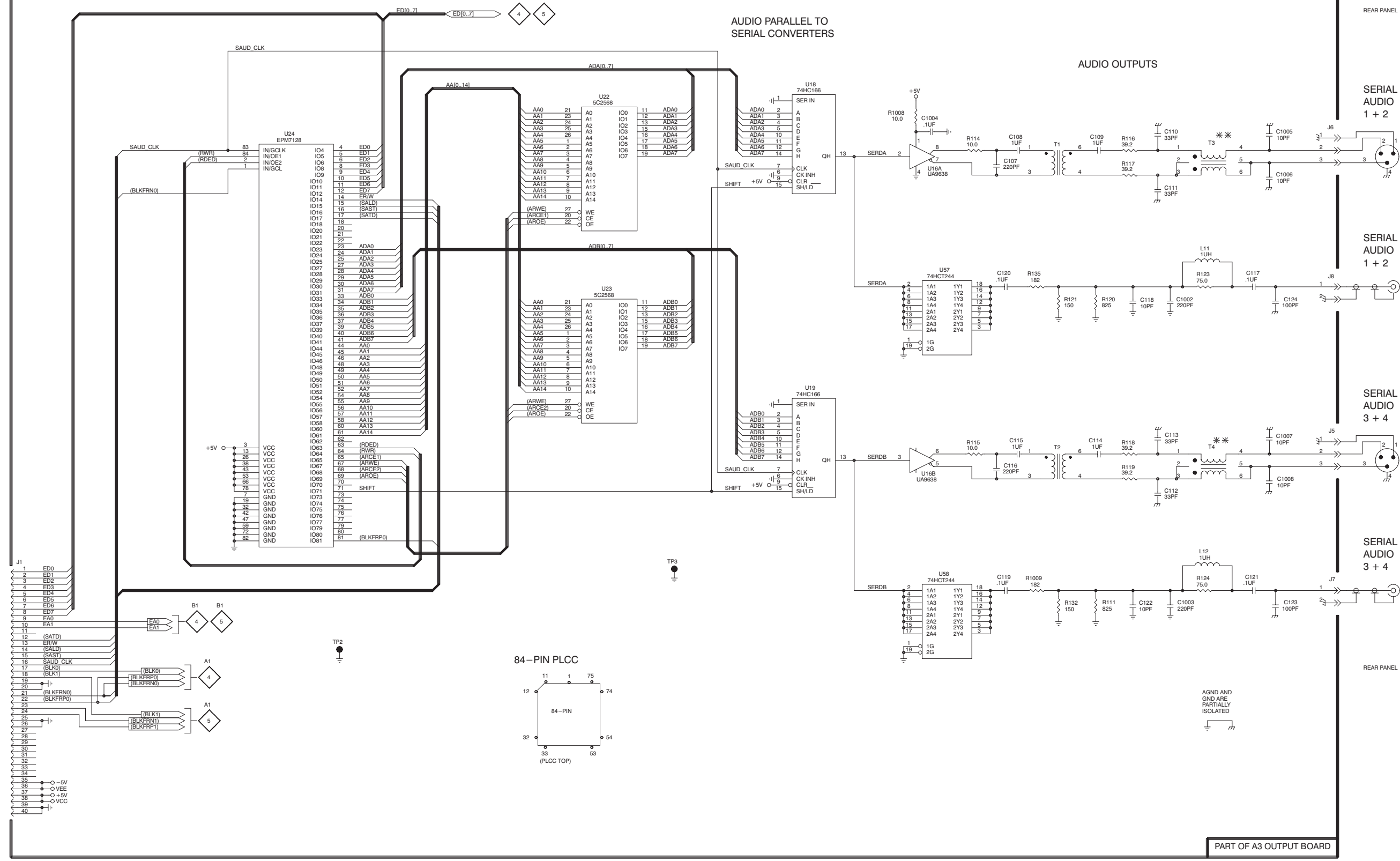

84-PIN PLCC

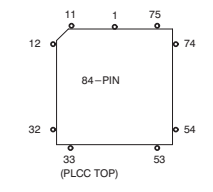

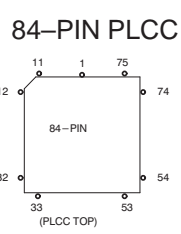
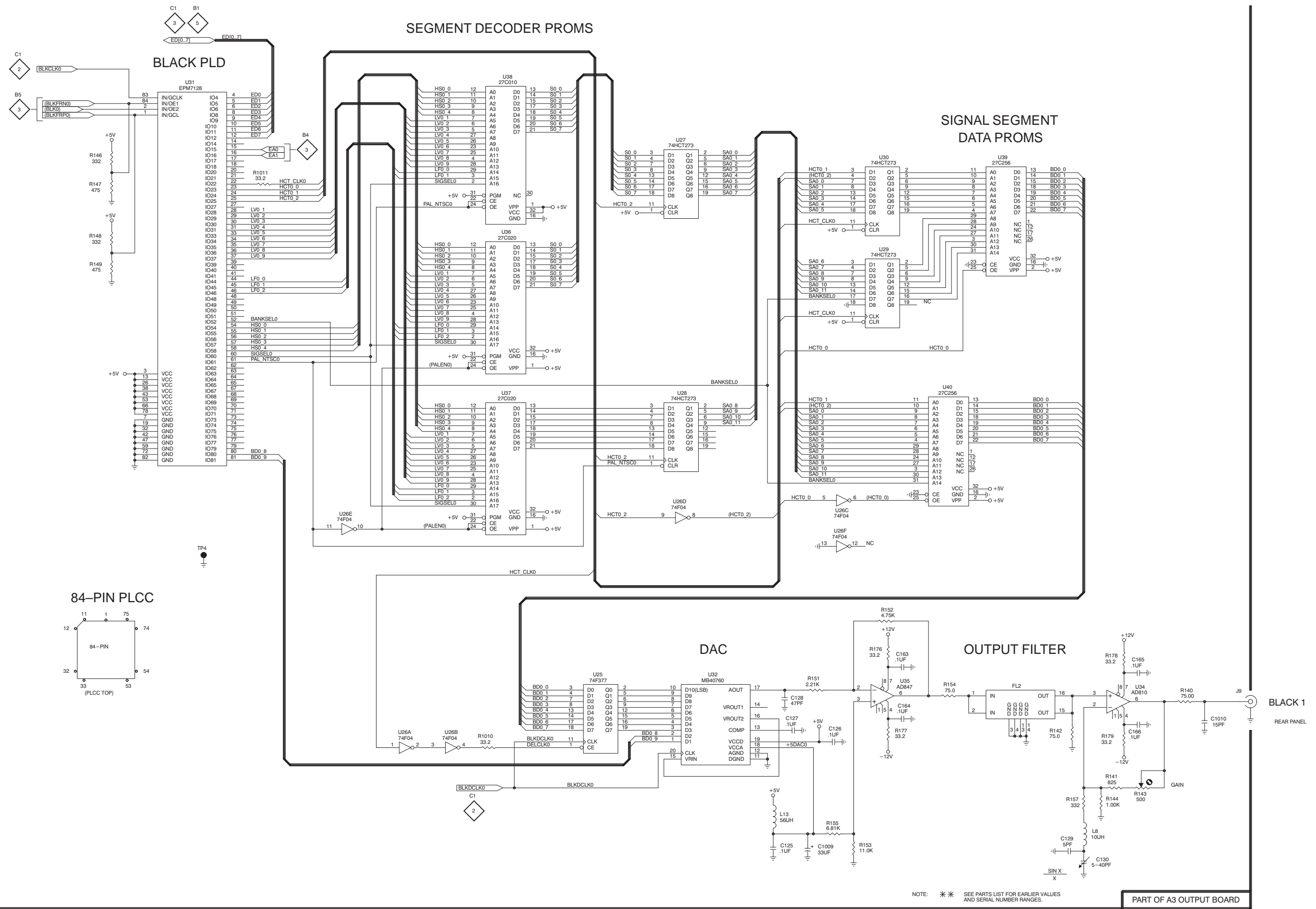

NOTE: ** SEE PARTS LIST FOR EARLIER VALUES AND SERIAL NUMBER RANGES.

PART OF A3 OUTPUT BOARD

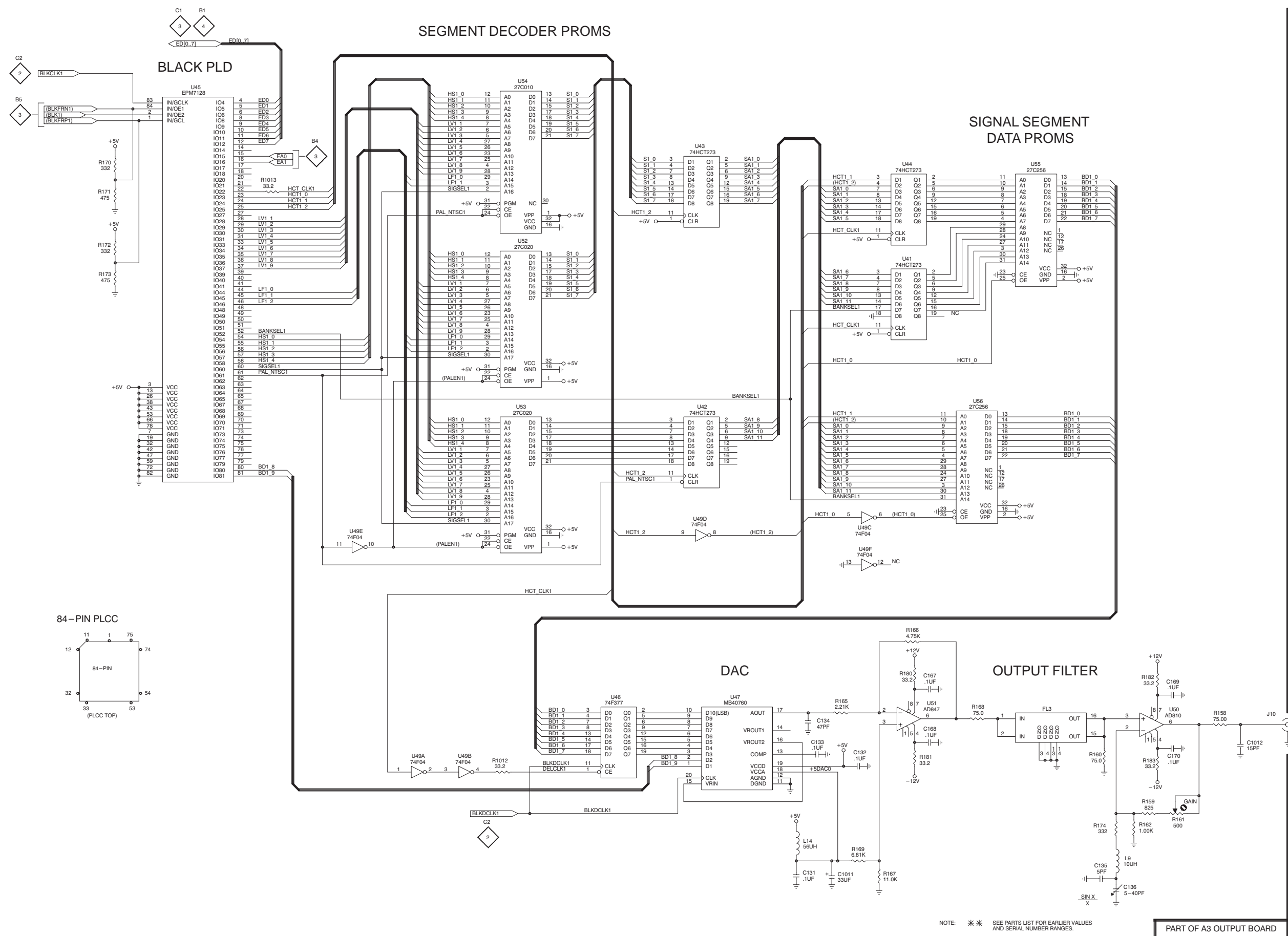

NOTE: * * SEE PARTS LIST FOR EARLIER VALUES AND SERIAL NUMBER RANGES.

PART OF A3 OUTPUT BOARD

BLACK 2
REAR PANEL

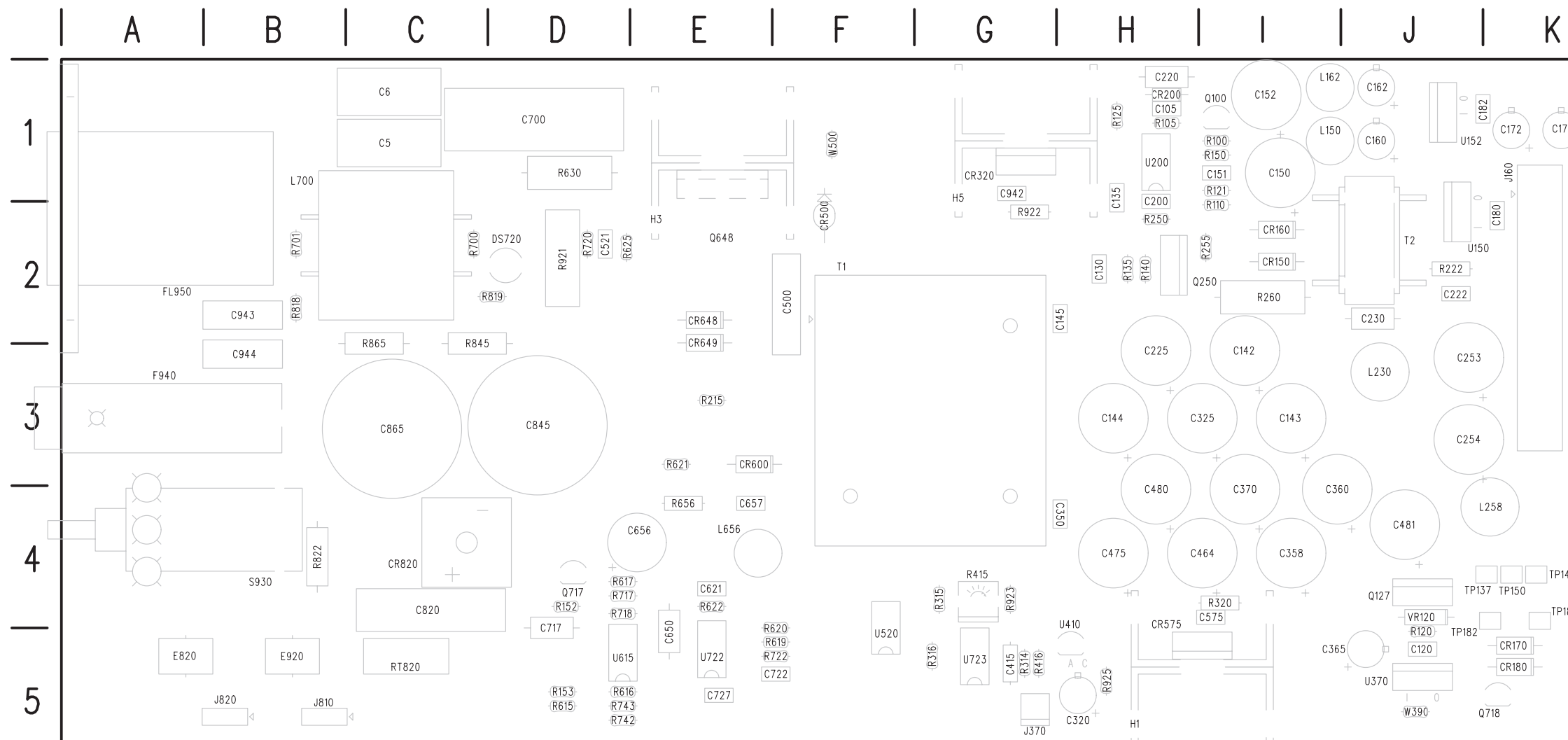

 **Static Sensitive Devices**
See Maintenance Section

A4 Power Supply Board

671-3242-01

A4 Power Supply Board and Diagram <1> Component Locator

		1/2		1/2		1/2		1/2		1/2		1/2		1/2		1/2			
C5	1	D1	C1	C225	1	E3	H3	C657	1	C2	E4	CR649	1	C3	E3	L258	1	G2	J4
C6	1	D1	C1	C230	1	E3	J2	CR820	1	B1	C4	L656	1	C2	E4	L700	1	D1	B1
C105	1	D4	H1	C253	1	F3	J3	C700	1	D1	D1	C717	1	B5	D5	DS720	1	C1	D2
C120	1	G2	J5	C254	1	G2	J3	C717	1	B5	D5	C722	1	A3	E5	C727	1	A3	E5
C130	1	D4	H2	C320	1	E5	H5	C820	1	B1	C4	C820	1	B1	C4	E820	1	B1	A5
C135	1	D3	H2	C325	1	F3	H3	C845	1	C1	D3	E920	1	B1	B5	F940	1	A1	A3
C142	1	E3	I3	C350	1	D2	H4	C865	1	C1	C3	F950	1	A1	A2	FL950	1	A1	A2
C143	1	E3	I3	C358	1	F2	I4	C942	1	D3	G1	C942	1	D3	G1	C943	1	D1	B2
C144	1	F3	H3	C360	1	F2	I4	C943	1	D1	B2	C944	1	D1	B3	C944	1	D1	B3
C145	1	E3	H2	C365	1	H4	I5	C944	1	D1	B3	CR150	1	F3	I2	H1	1	D2	H5
C150	1	F3	I1	C370	1	E2	I4	CR160	1	F4	I2	H2	1	D2	H5	H2	1	D2	H5
C151	1	D4	I1	C415	1	E5	G5	CR170	1	G3	K5	H3	1	C3	E2	H3	1	C3	E2
C152	1	F3	I1	C464	1	E2	H4	CR180	1	G3	K5	H4	1	C3	E2	H4	1	C3	E2
C160	1	F3	J1	C475	1	E2	H4	CR1820	1	D3	H1	H5	1	E2	G2	H5	1	E2	G2
C162	1	F3	J1	C480	1	F2	H4	CR200	1	D3	H1	H6	1	E2	G2	H6	1	E2	G2
C170	1	G3	K1	C481	1	F2	H4	J160	1	H2	K1	J370	1	H4	G5	J370	1	H4	G5
C172	1	G3	K1	C500	1	C2	F2	J810	1	B1	B5	J810	1	B1	B5	J810	1	B1	B5
C180	1	G3	K2	C521	1	C5	D2	J820	1	B2	B5	J820	1	B2	B5	J820	1	B2	B5
C182	1	G3	K1	C575	1	D2	I4	CR320	1	D3	G1	CR500	1	C2	F2	CR500	1	C2	F2
C200	1	E3	H2	C621	1	A3	E4	CR575	1	D2	H5	CR600	1	C2	E3	CR575	1	D2	H5
C220	1	E4	H1	C650	1	B3	E5	CR600	1	C2	E3	CR648	1	B3	E2	CR600	1	C2	E3
C222	1	E4	J2	C656	1	B3	D4	CR648	1	B3	E2	L150	1	F3	I1	CR648	1	B3	E2
								L162	1	F3	I1	L162	1	F3	I1	L162	1	F3	I1
								L230	1	F3	J3	L230	1	F3	J3	L230	1	F3	J3

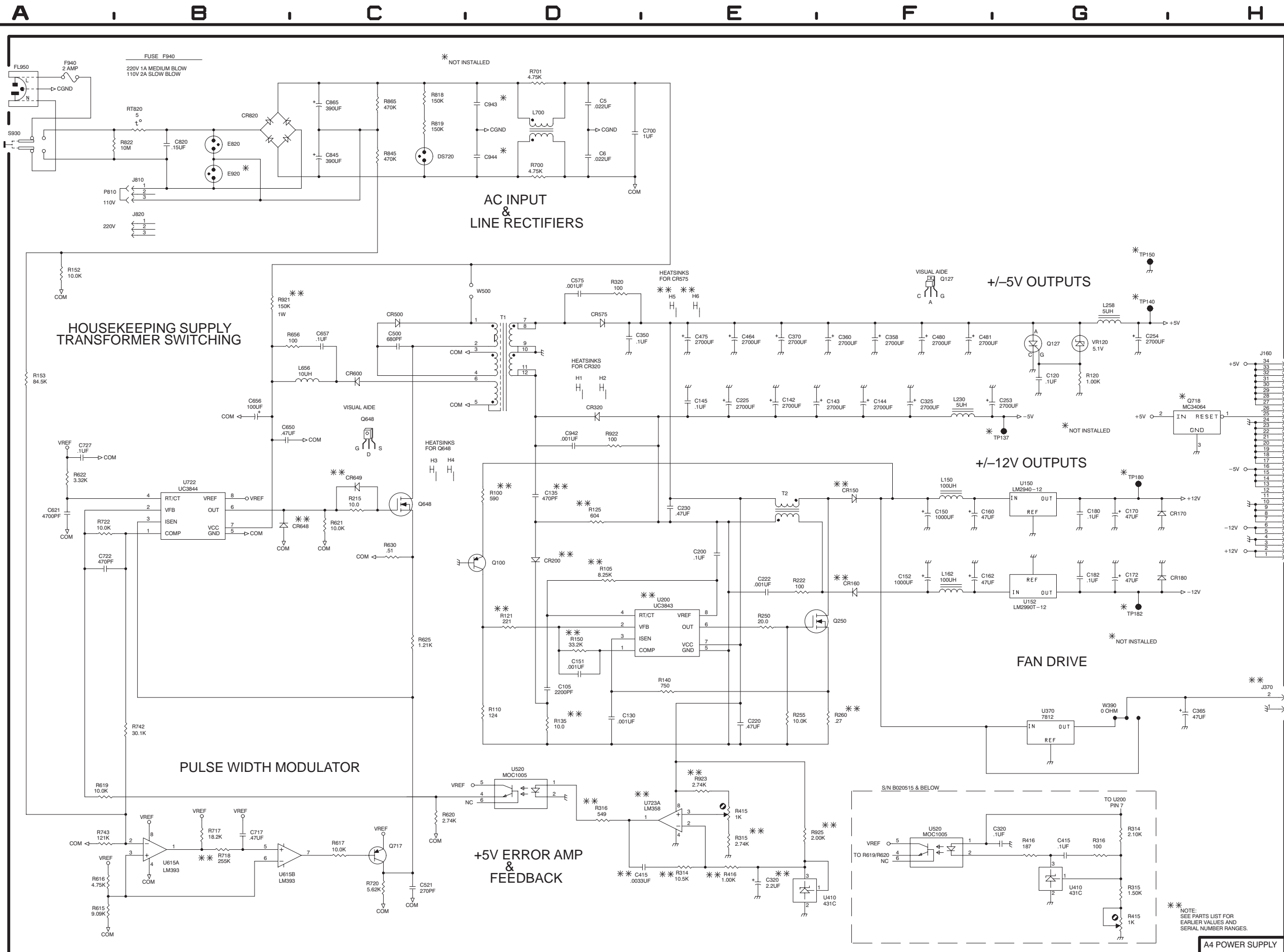

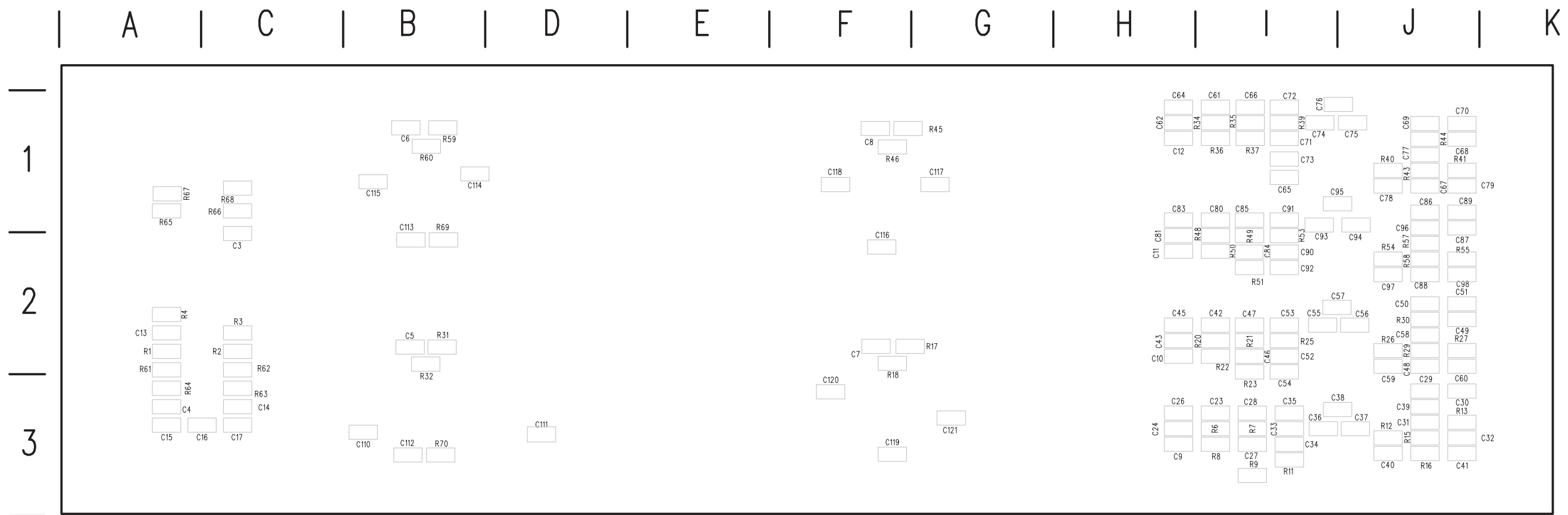

 **Static Sensitive Devices**
See Maintenance Section

A5 Opt 1 Black Generator Board (Back)

Front of Board Illustration and component locator is on the back of this page.

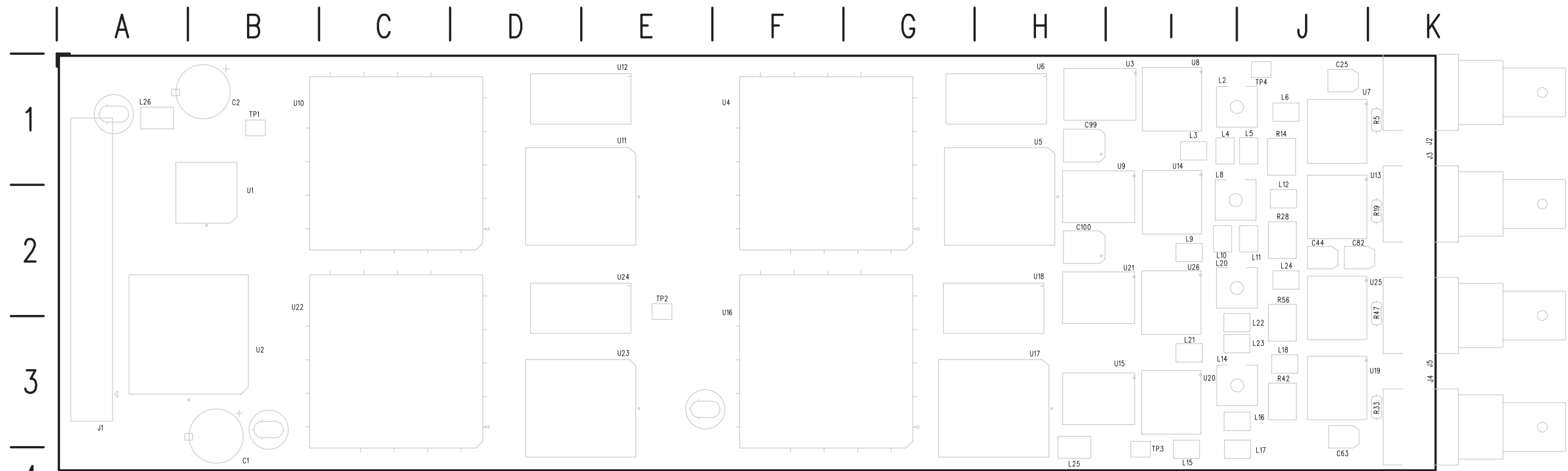

Static Sensitive Devices
See Maintenance Section

A5 Opt 1 Black Generator Board (Front)

A5 Component Board and Diagram <1> Component Locator

(with cross-references to schematic diagrams 2, 3, and 4).

1/2				1/2				1/2				1/2				1/2				1/2				1/2																			
C1	1	E4	B4	C28 †	1	E1	I1	C50 †	2	G3	J2	C72 †	4	E2	I3	C93 †	3	E2	I2	J1	1	A2	A3	L20	3	E2	I2	R16 †	1	G2	J1	R40 †	4	G2	J3	R61 †	1	B5	A2	U7	1	H1	J1
C2	1	F5	B1	C29 †	1	H2	J1	C51 †	2	H2	J2	C73 †	4	E2	I3	C94 †	3	F2	J2	J2	1	H1	K1	L21	3	E3	I3	R17 †	1	C1	F2	R41 †	4	G2	J3	R62 †	1	B5	B2	U8	1	E1	I1
C3 †	1	E4	B2	C30 †	1	H1	J1	C52 †	2	E2	I2	C74 †	4	E2	I3	C95 †	3	F2	J3	J3	2	H2	K1	L22	3	E2	J3	R18 †	1	C1	F1	R42 †	4	G2	J3	R63 †	1	B5	B1	U9	2	C2	I1
C4 †	1	F4	A1	C31 †	1	G2	J1	C53 †	2	E2	I2	C75 †	4	F2	J3	J4	4	H2	K3	L23	3	F2	J3	R19	2	H2	K2	R43 †	4	G3	J3	R64 †	1	B5	A1	U10	2	B2	B1				
C5 †	1	F4	C2	C32 †	1	H2	J1	C54 †	2	E2	I1	C76 †	4	F2	J3	J5	3	H2	K3	L24	3	F2	J2	R20 †	2	D2	I2	R44 †	4	G3	J3	R65 †	1	B3	A3	U11	2	C4	E1				
C6 †	1	F4	C3	C33	1	F1	I1	C55 †	2	E2	I2	C77 †	4	F2	J3	C96 †	3	F2	J2	L25	1	F3	H4	R21 †	2	D2	I2	R45 †	4	B1	F3	R66	1	B3	B3	U12	2	C2	E1				
C7 †	1	F4	F2	C34	1	F2	I1	C56 †	2	F2	J2	C78 †	4	F2	J3	C97 †	3	F2	J2	L26	1	F3	A1	R22 †	2	D2	I2	R46 †	4	B1	F3	R67 †	1	B3	A3	U13	2	G2	K1				
C8 †	1	F4	F3	C35 †	1	F2	I1	C57 †	2	F2	J2	C79 †	4	F2	J3	C98 †	3	F2	J2	L2	1	F2	I1	R23 †	2	D2	I1	R47	3	H2	K3	R68	1	B2	B3	U14	2	D2	I1				
C9 †	1	G4	H1	C36 †	1	F2	I1	C58 †	2	F2	J2	C80 †	3	D3	I3	C99	1	F3	H1	L3	1	F2	I1	R24 †	2	E2	I2	R48 †	3	D2	I2	R69 †	3	C4	C3	U15	4	C2	I3				
C10 †	1	G4	I2	C37 †	1	F2	J1	C59	2	F2	J1	C81 †	3	D3	H2	C100	1	F3	H2	L4	1	F1	I1	R25 †	2	E2	I2	R49 †	3	D2	I2	R70 †	2	C4	C1	U16	4	B2	F2				
C11 †	1	G4	I2	C38 †	1	G2	J1	C60 †	2	F2	J1	C82	3	G3	J2	C101 †	1	E5	C1	L5	1	G1	J1	R26 †	2	G2	J2	R50 †	3	D2	I2	U17	4	C4	H3								
C12 †	1	G4	H3	C39 †	1	G2	J1	C61 †	4	D3	I3	C83 †	3	D2	H3	C102 †	1	E5	C1	L6	1	G1	J1	R27 †	2	G2	J2	R51 †	3	D2	I2	TP1	1	F5	B1	U18	4	C2	H2				
C13 †	1	F5	A2	C40 †	1	G2	J1	C62 †	4	D3	H3	C84 †	3	D2	I2	C103 †	1	F5	C3	L7	2	E3	I2	R28	2	G2	J2	R52 †	3	D2	I2	TP2	1	F5	E2	U19	4	G2	K3				
C14 †	1	F5	B1	C41 †	1	G1	J1	C63	4	D3	H3	C85 †	3	D2	I3	C104 †	1	F5	C3	L8	2	E2	I1	R29 †	2	G3	J2	R53 †	3	E2	I2	TP3	1	F5	I4	U20	4	D2	I3				
C15 †	1	F5	A1	C42 †	2	D3	I2	C64 †	4	D3	H2	C86	3	D2	I3	C105 †	1	F5	C3	L9	2	E2	I2	R30 †	2	G3	J2	R54 †	3	G2	J2	TP4	1	F5	J1								
C16 †	1	F5	B1	C43 †	2	D3	H2	C65 †	4	D2	H3	C87 †	3	G2	J3	C106 †	1	F5	F2	L10	2	E2	I2	R31	2	B1	C2	R55 †	3	G2	J2	U21	3	C2	I2								
C17 †	1	G5	B1	C44	2	G3	J2	C66 †	4	D2	I3	C88 †	3	G2	J2	C107 †	1	F5	G3	L11	2	F2	J2	R32	2	B1	C1	R56 †	3	G2	J2	U22	3	B2	B2								
C23 †	1	E2	I1	C45 †	2	D2	H2	C67 †	4	D2	I3	C89 †	3	G2	J2	C108 †	1	F5	G3	L12	2	F2	J2	R33 †	4	H2	K3	R57 †	3	G3	J2	U23	3	C4	E3								
C24 †	1	E2	I1	C46	2	D2	I2	C68 †	4	D2	I3	C90 †	3	H2	J3	C109 †	1	G5	F3	L13	4	E2	I3	R34 †	4	D2	I3	R58 †	3	G3	J2	U24	3	C2	E2								
C25	1	G2	J1	C47 †	2	D2	I2	C69 †	4	G2	J3	C91 †	3	E2	I2	C110 †	1	G5	F1	L14	4	E2	I3	R35 †	4	D2	I3	R59 †	3	B1	C3	U4	1	C1	F1								
C26	1	E1	H1	C48 †	2	D2	I2	C70 †	4	G3	J3	C92 †	3	E2	I3	C111 †	1	G5	F1	L15	4	E2	J3	R36 †	4	D2	I3	R60 †	3	B1	C3	U5	1	D3	H1								
C27 †	1	E2	I1	C49 †	2	G2	J2	C71 †	4	H2	J3	C71 †	4	E2	I2	C112 †	1	G5	G1	L16	4	E2	J3	R37 †	4	D2	I3	U6	1	D1	H1												
												C113 †	1	G5	G1	L17	4	F2	J4	R38 †	4	D2	I3																				
												C114 †	1	G5	G1	L18	4	F2	J3	R39 †	4	E2	I3																				
												C115 †	1	G5	G1																												

†Parts located on back of board

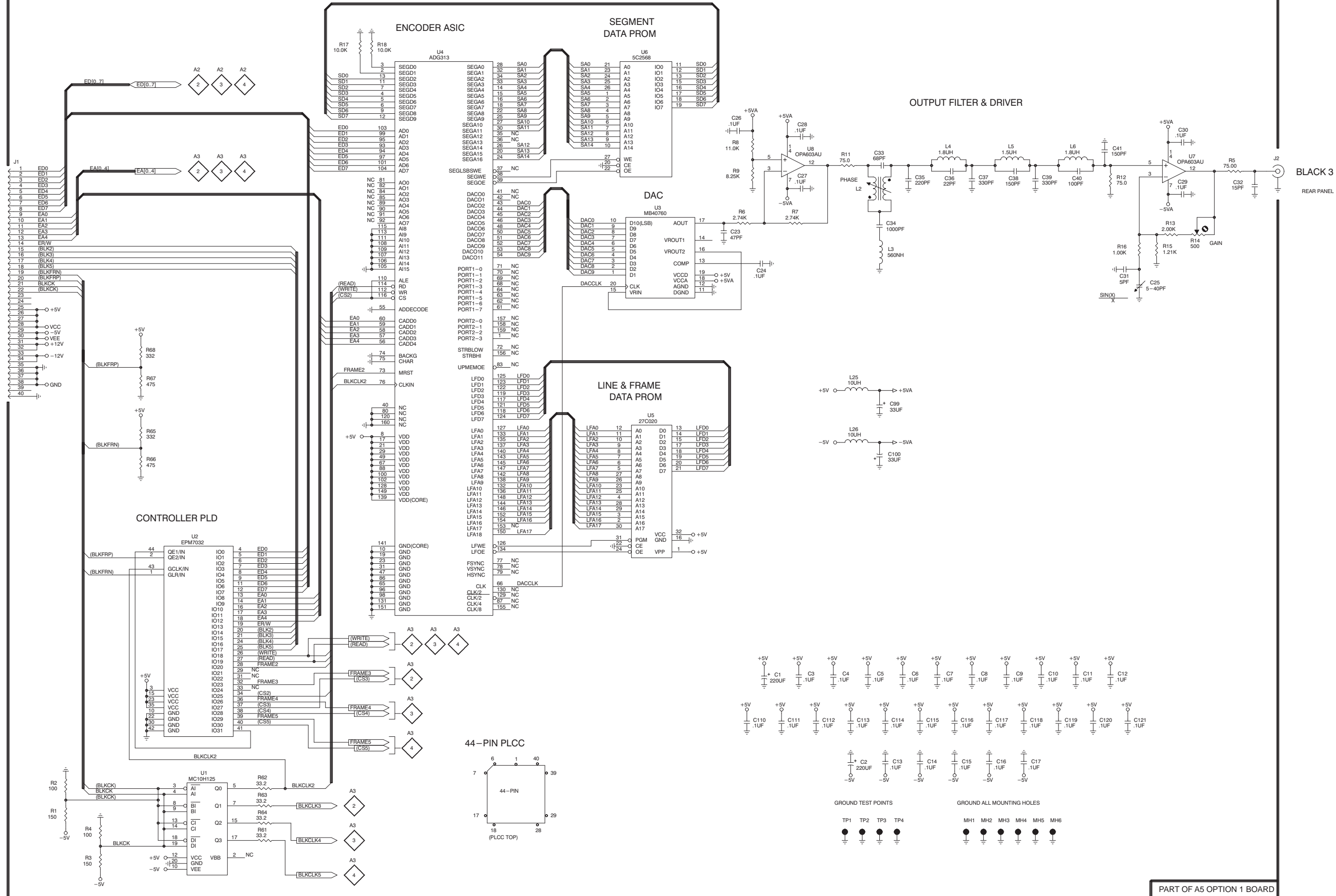

BLACK 3
REAR PANEL

PART OF A5 OPTION 1 BOARD

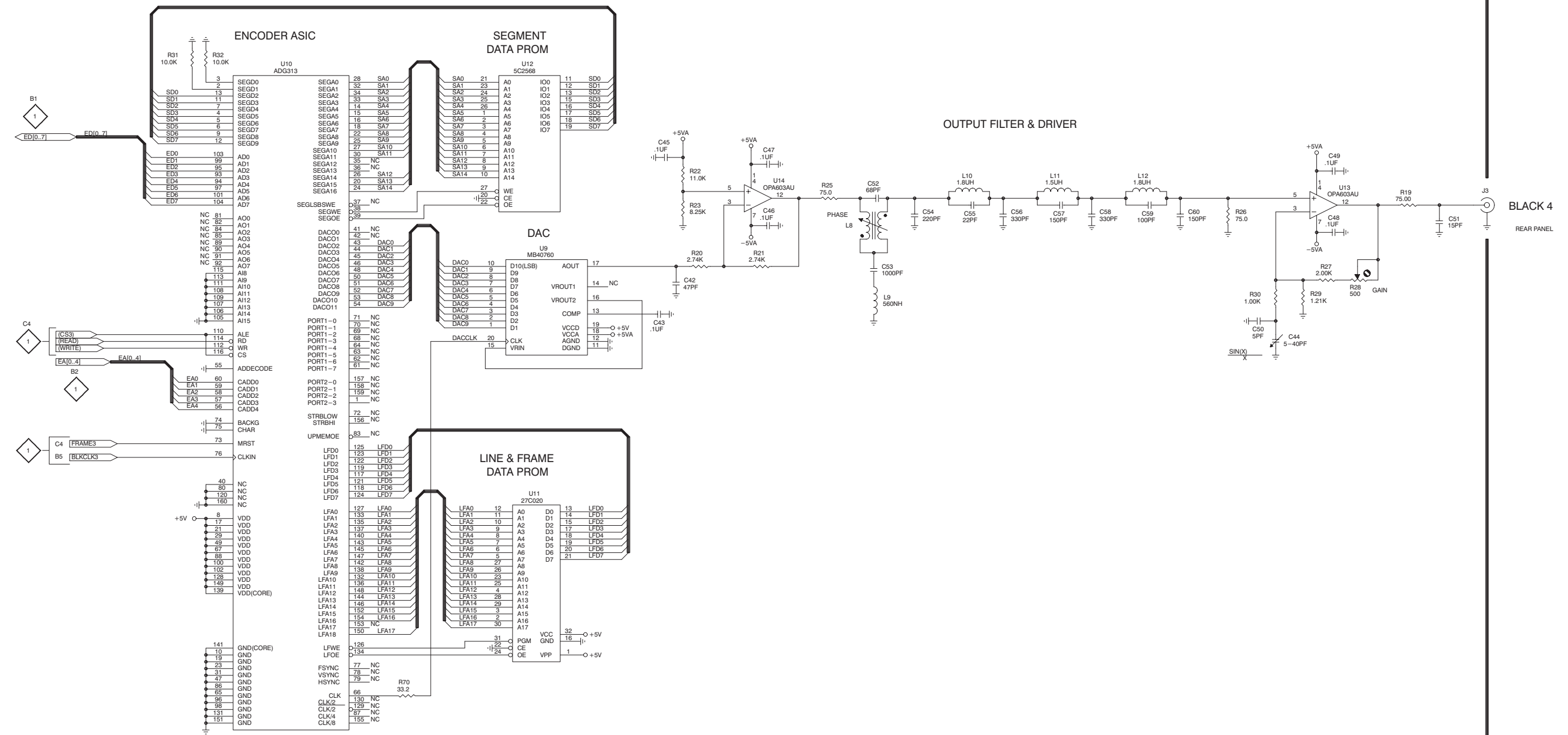

PART OF A5 OPTION 1 BOARD

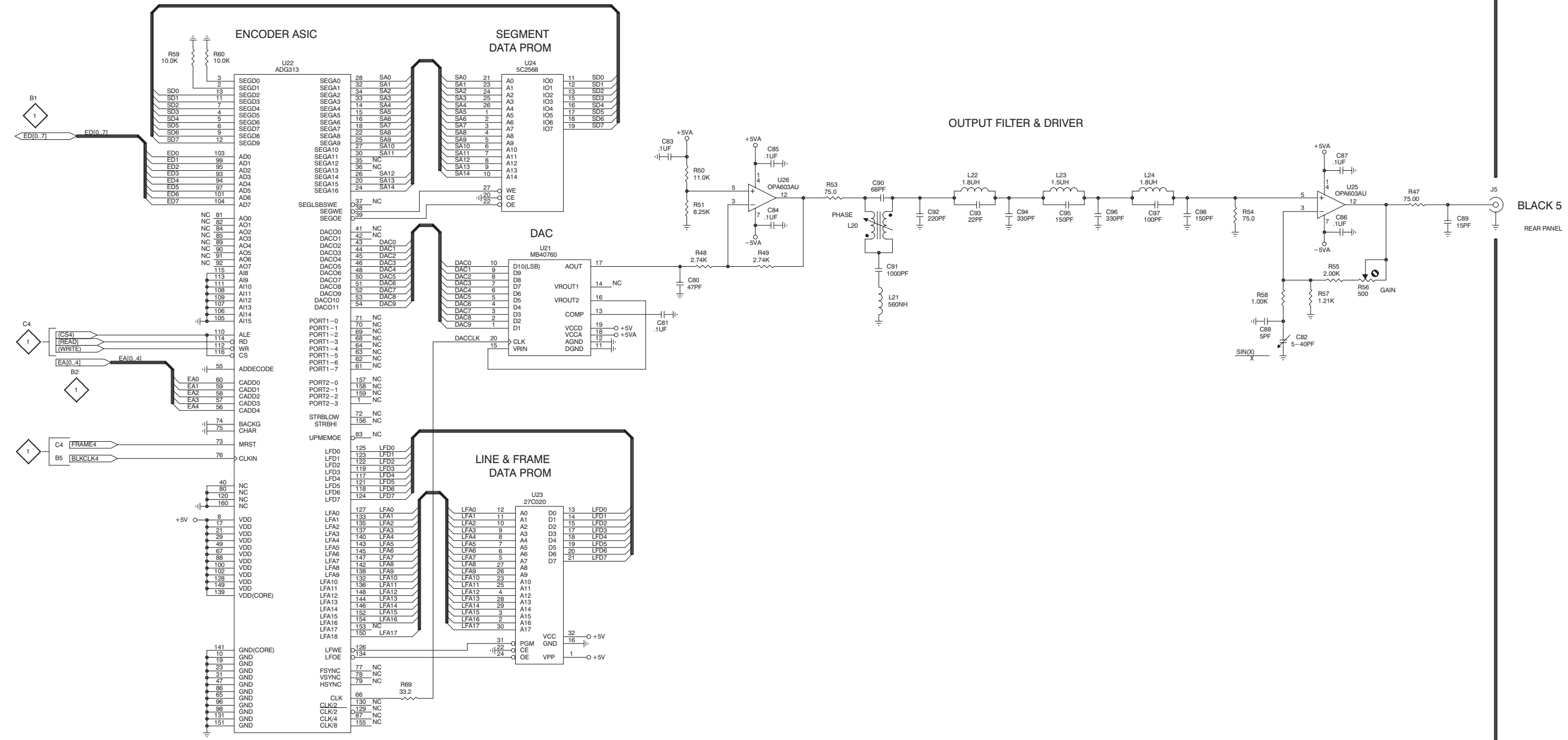

PART OF A5 OPTION 1 BOARD

1

2

3

4

5

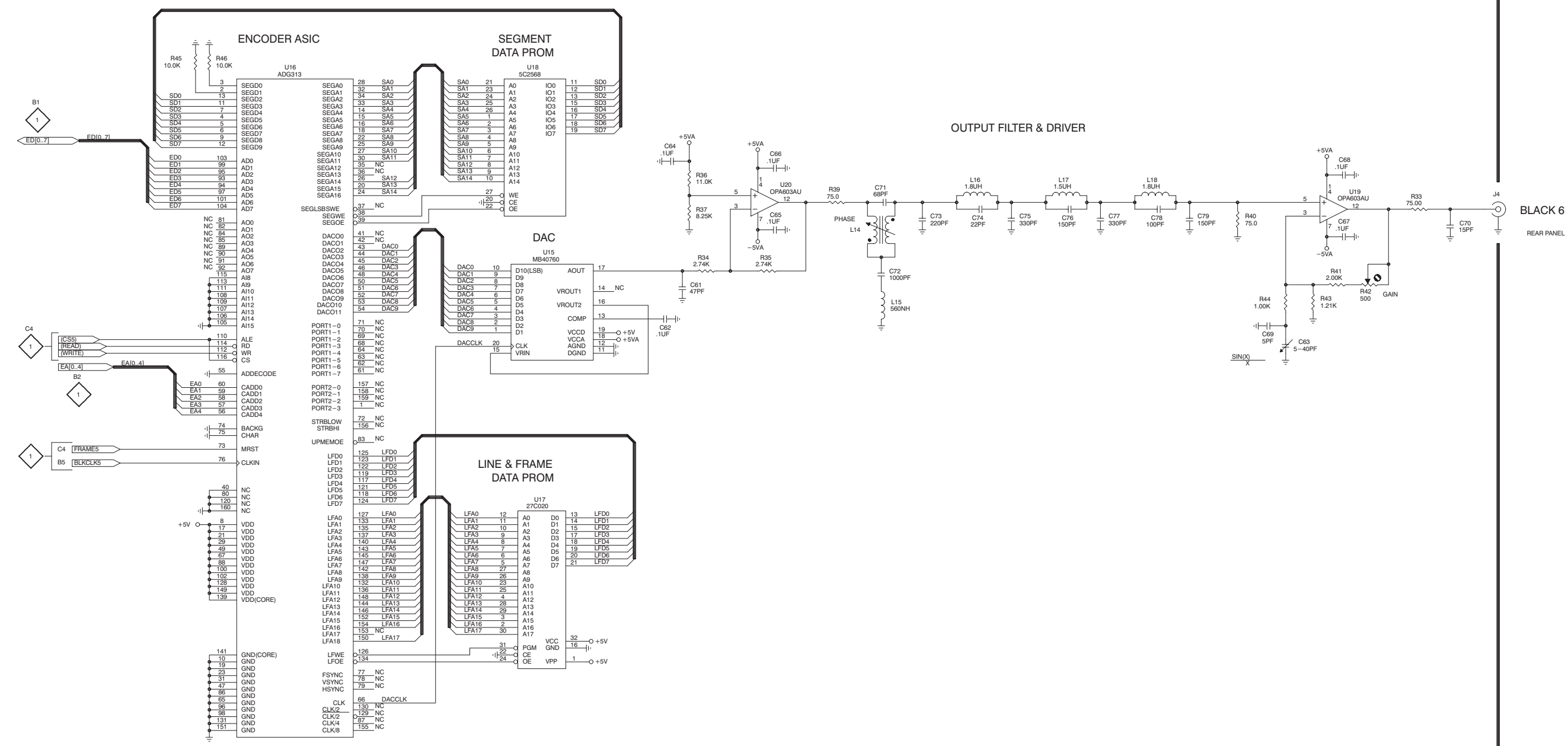

PART OF A5 OPTION 1 BOARD

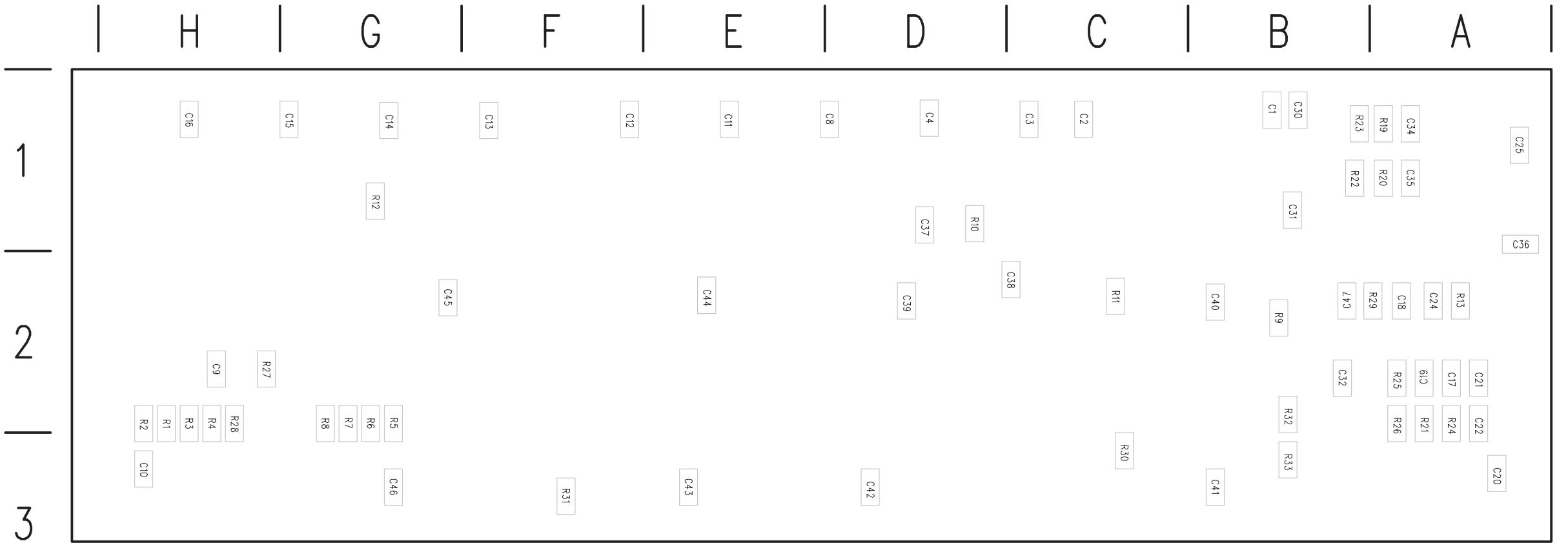

A6 Option 2 Test Signal Generator Board (Back)

 **Static Sensitive Devices**
See Maintenance Section

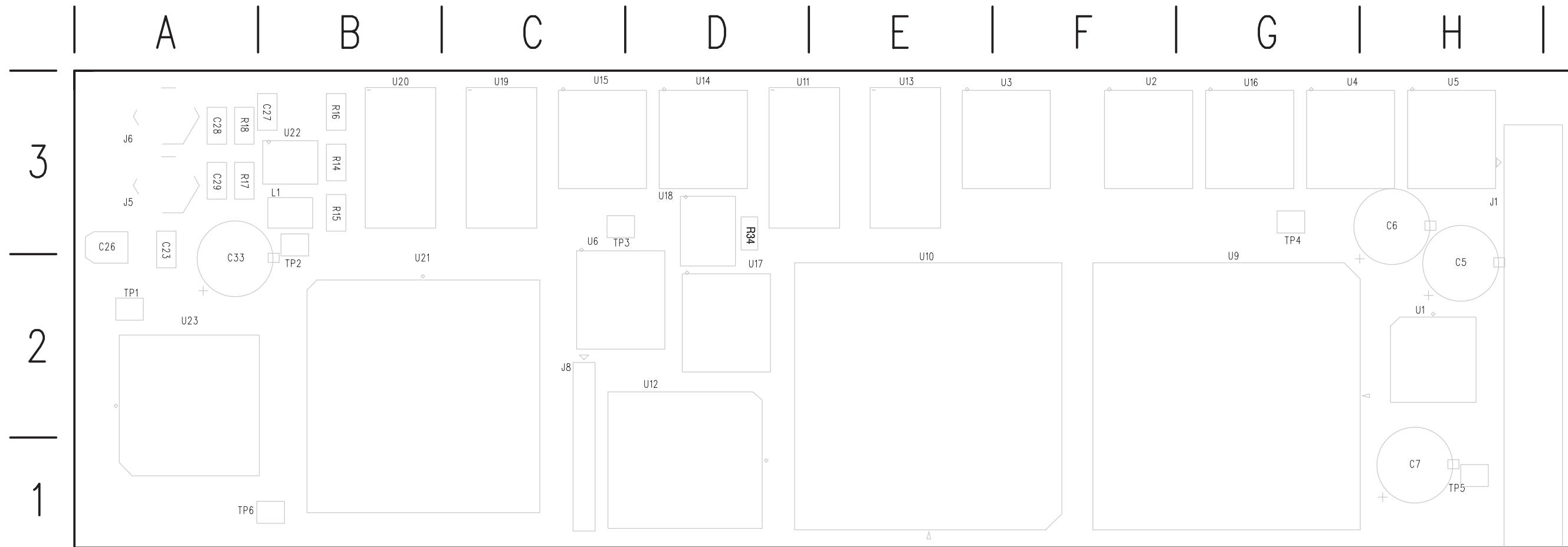

 **Static Sensitive Devices**
See Maintenance Section

A6 Option 2 Test Signal Generator Board (Front)

Back of Board Illustration located on back of this page.

A6 Option 2 Test Signal Generator Board and Diagram <1> Component Locator

(with cross-references to schematic diagrams 2).

1/2				1/2				1/2				1/2				1/2				1/2				1/2																																																																																																																																																																																																																																																																																																																																																																																											
C1 †	1	C5	B1	C17 †	2	G3	A2	C32 †	2	G3	B2	C47 †	2	E4	B2	R8 †	1	A4	G2	R23 †	2	G4	B1	TP4	2	G2	G1	U13	1	G4	E1	C2 †	1	C5	C1	C18 †	2	G3	A2	C33 †	2	G3	A2	C48 †	1	A1	H1	R9 †	2	D3	B2	R24 †	2	F4	A2	TP5	2	G2	H3	U14	2	B1	D1	C3 †	1	C5	C1	C19 †	2	G3	A2	C34 †	2	H4	A1	J1	1	A1	H1	R10 †	2	B4	D1	R25	2	D5	A2	TP6	2	F2	A3	U15	2	B2	C1	C4 †	1	C5	D1	C20 †	2	G3	A3	C35 †	2	H4	A1	J5	2	H4	A1	R11 †	2	A4	C2	R26 †	2	E5	A2	U16	2	C3	G1	C5	1	B5	H2	C21 †	2	E5	A2	C36 †	2	E5	A1	J6	2	H4	A1	R12 †	2	B3	G1	R27 †	1	C2	H2	U17	2	C4	D2	C6	1	B5	H1	C22	2	E5	A2	C37 †	1	D5	D1	J8	2	A5	C2	R13	2	E5	A2	R28	1	D2	H2	U18A	2	B5	D1	C7	1	F5	H3	C23	2	E5	A1	C38 †	1	D5	C2	L1	2	G2	B1	R14	2	F4	B1	R29	2	E4	A2	U18B	2	B4	D1	C8 †	1	C5	D1	C24 †	2	E5	A2	C39 †	1	D5	D2	R15	2	F4	B1	R30 †	2	B5	C3	U18C	2	B4	D1	C9 †	1	F5	H2	C25 †	2	E5	A1	C40 †	1	E5	B2	R16	2	F4	B1	R31 †	2	A5	F3	U18D	2	B3	D1	C10 †	1	F5	H3	C26	2	E5	A1	C41 †	1	E5	B3	R17	2	G4	A1	R32 †	2	D3	B2	U19	2	C1	C1	C11 †	1	D5	E1	C27	2	E5	A1	R18	2	G4	A1	R33 †	2	D3	B3	U20	2	C2	B1	C12 †	1	D5	F1	C28	2	H4	A1	R19 †	2	H4	A1	R34 †	2	B3	D3	U21	2	E2	B2	C13 †	2	E3	F1	C29	2	H4	A1	R20 †	2	H4	A1	U22	2	G4	B1	C14 †	2	F3	G1	C30 †	2	G3	B1	C42 †	1	E5	D3	R21	2	E5	A2	TP1	2	E5	A2	U10	1	D3	E2	C15 †	2	F3	G1	C31 †	2	G3	B1	C43 †	1	E5	E3	R22	2	G4	B1	TP2	2	G2	B2	U11	1	G4	D1	C16 †	2	F3	H1	C32 †	2	G3	B1	C44 †	1	E5	E2	TP3	2	G2	C1	U12	1	E4	D2

†Parts located on Back of Board.

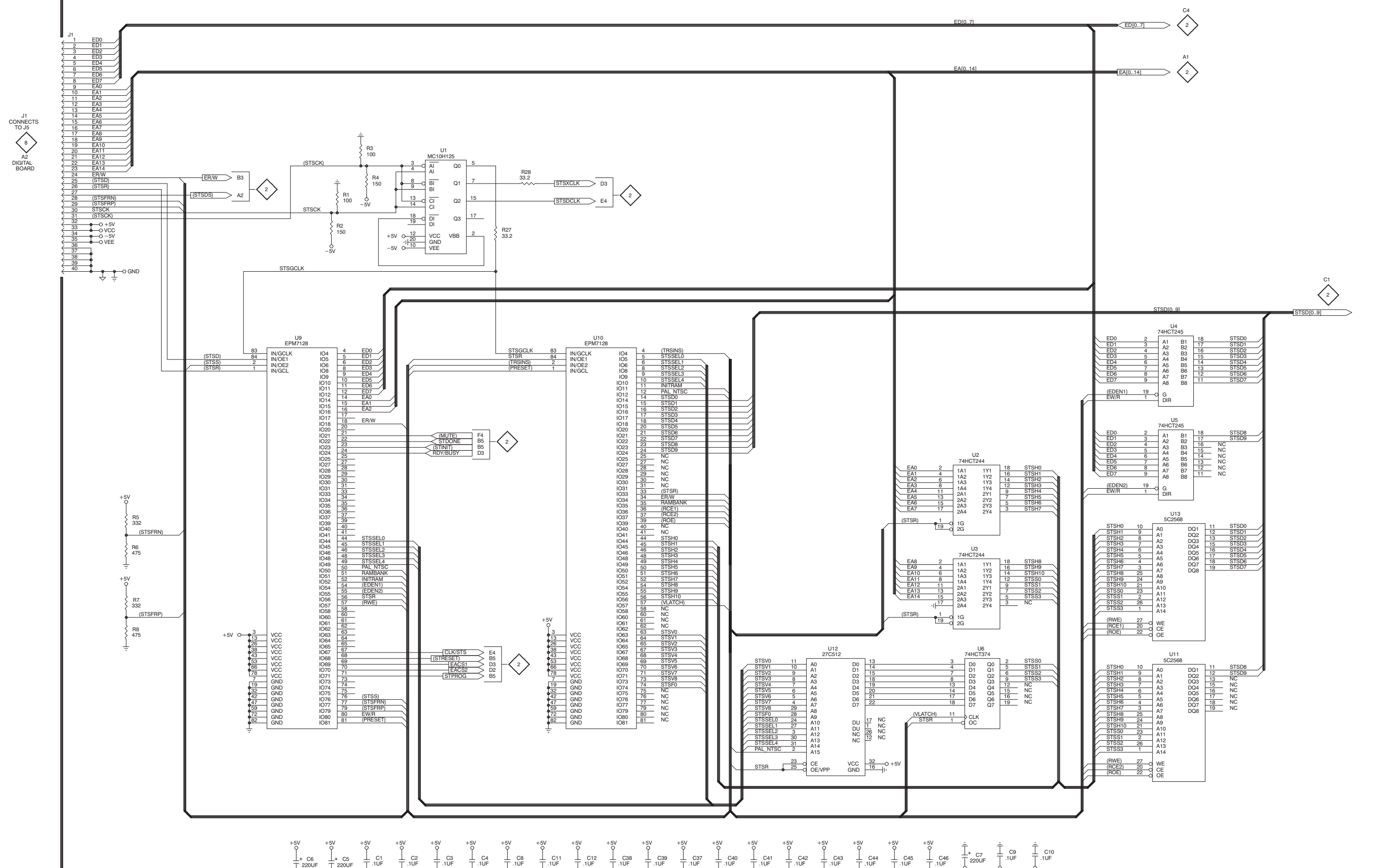

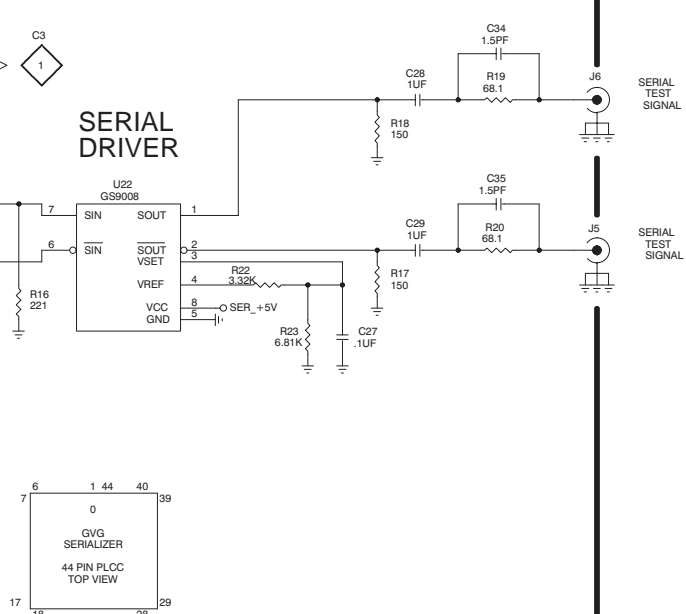
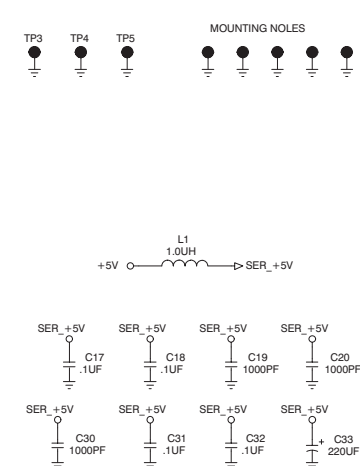
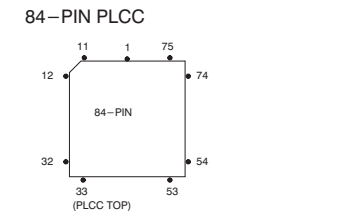
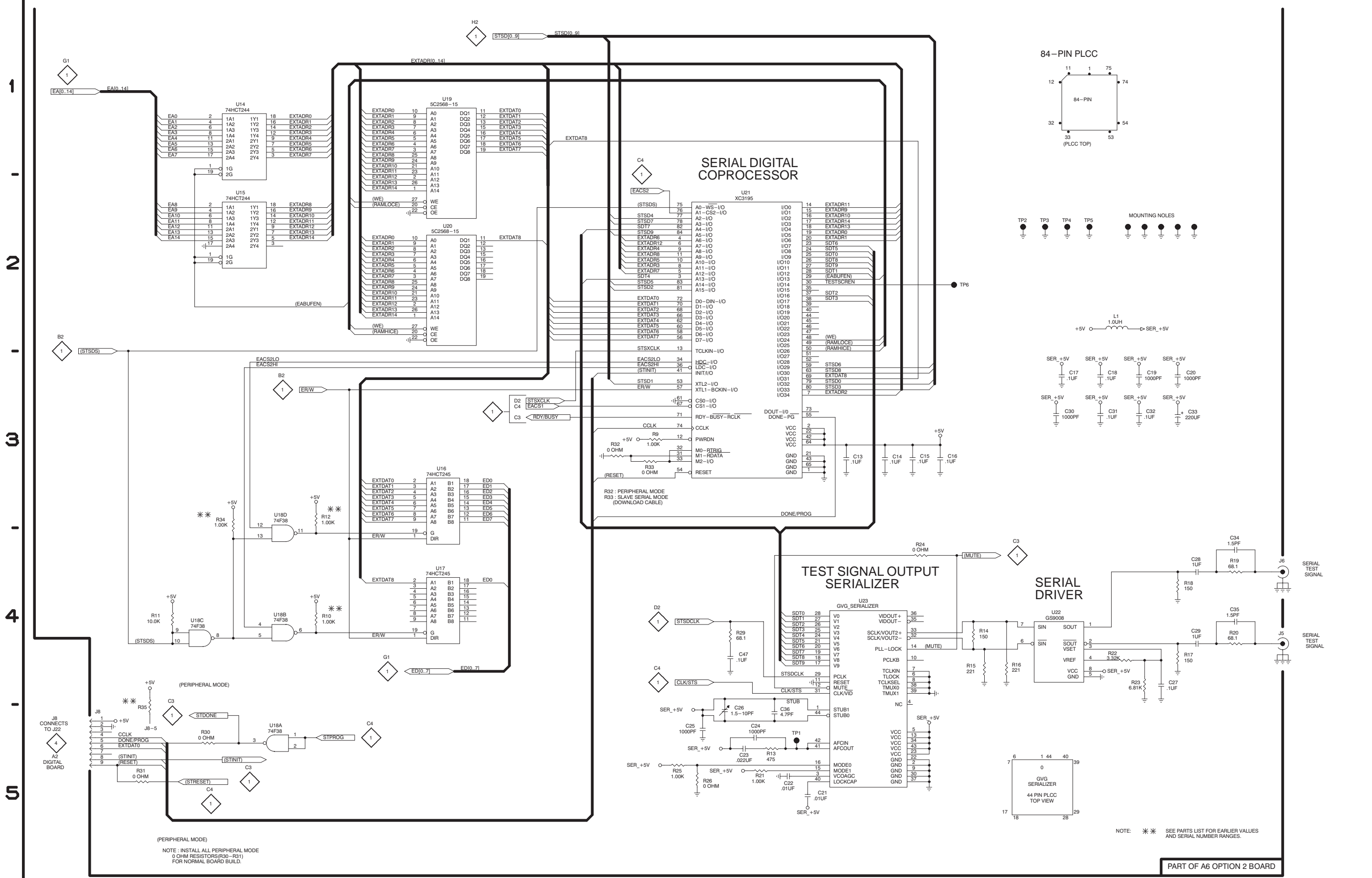

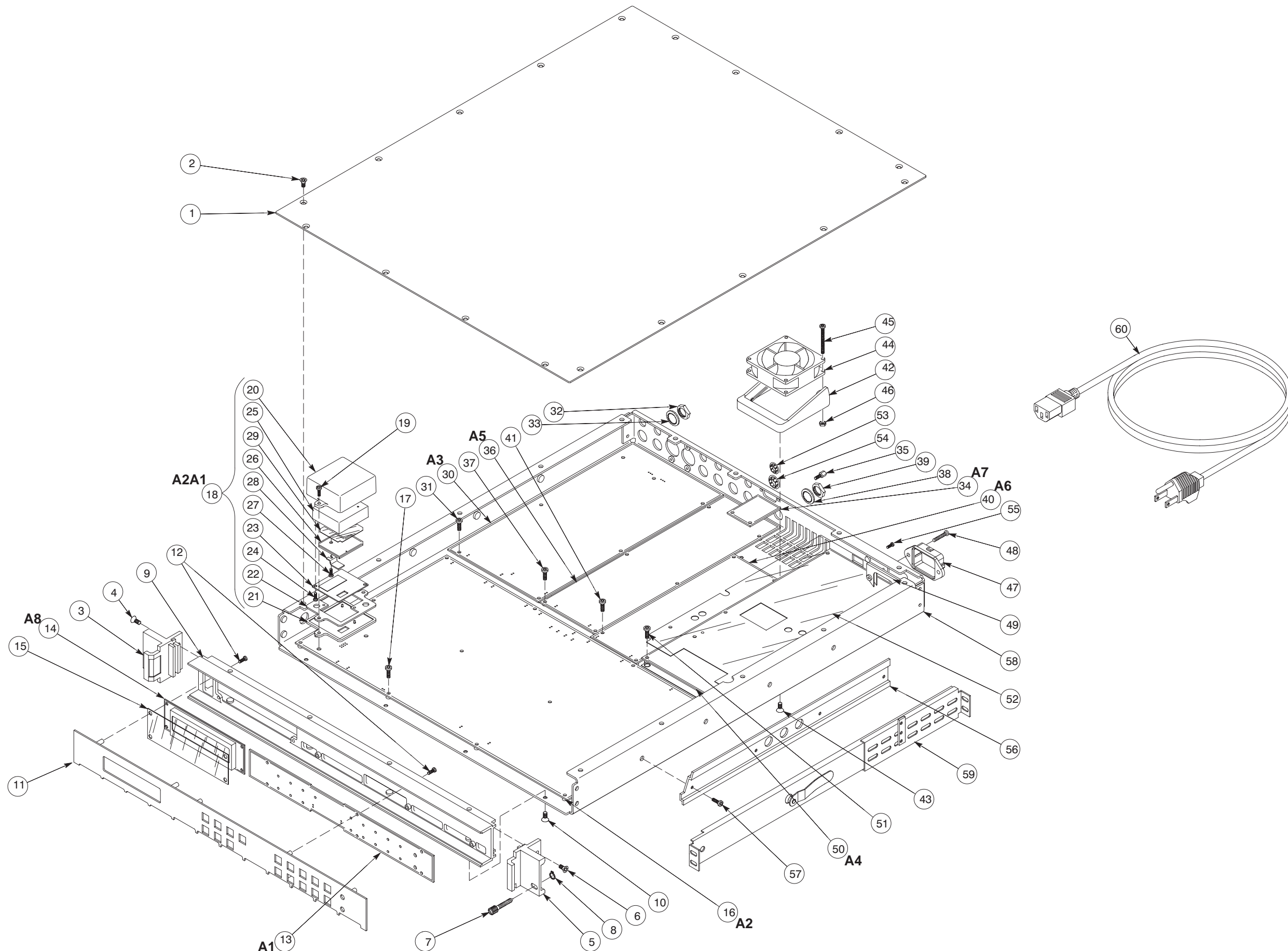

Fig. 1 Exploded view

Replaceable Mechanical Parts

This section contains a list of the replaceable mechanical components for the SPG 422. Use this list to identify and order replacement parts.

Parts Ordering Information

Replacement parts are available through your local Tektronix field office or representative.

Changes to Tektronix products are sometimes made to accommodate improved components as they become available and to give you the benefit of the latest improvements. Therefore, when ordering parts, it is important to include the following information in your order:

- Part number
- Instrument type or model number
- Instrument serial number
- Instrument modification number, if applicable

If you order a part that has been replaced with a different or improved part, your local Tektronix field office or representative will contact you concerning any change in part number.

Change information, if any, is located at the rear of this manual.

Using the Replaceable Mechanical Parts List

The tabular information in the Replaceable Mechanical Parts List is arranged for quick retrieval. Understanding the structure and features of the list will help you find all of the information you need for ordering replacement parts. The following table describes the content of each column in the parts list.

Parts list column descriptions

Column	Column name	Description
1	Figure & index number	Items in this section are referenced by figure and index numbers to the exploded view illustrations that follow.
2	Tektronix part number	Use this part number when ordering replacement parts from Tektronix.
3 and 4	Serial number	Column three indicates the serial number at which the part was first effective. Column four indicates the serial number at which the part was discontinued. No entry indicates the part is good for all serial numbers.
5	Qty	This indicates the quantity of parts used.
6	Name & description	An item name is separated from the description by a colon (:). Because of space limitations, an item name may sometimes appear as incomplete. Use the U.S. Federal Catalog handbook H6-1 for further item name identification.
7	Mfr. code	This indicates the code of the actual manufacturer of the part.
8	Mfr. part number	This indicates the actual manufacturer's or vendor's part number.

Abbreviations Abbreviations conform to American National Standard ANSI Y1.1-1972.

Chassis Parts Chassis-mounted parts and cable assemblies are located at the end of the Replaceable Electrical Parts List.

Mfr. Code to Manufacturer Cross Index The table titled Manufacturers Cross Index shows codes, names, and addresses of manufacturers or vendors of components listed in the parts list.

Manufacturers cross index

Mfr. code	Manufacturer	Address	City, state, zip code
S3109	FELLER	72 VERONICA AVE UNIT 4	SUMMERSET NJ 08873
TK0IU	OPTREX CORPORATION	3-14-9 YUSHIMA, BUNKYO-KU TOKYO	113 JAPAN
TK0435	LEWIS SCREW CO	4300 S RACINE AVE	CHICAGO IL 60609-3320
TK0941	BEARINGS INC (DIST)	2720 NW 29TH PO BOX 3005	PORTLAND OR 97210-1702
OJ4C1	TVT DIECASTING AND MFG INC	7330 SW LANDMARK LANE	PORTLAND OR 97223
OKB01	STAUFFER SUPPLY	810 SE SHERMAN	PORTLAND OR 97214
06666	GENERAL DEVICES CO INC	1410 S POST RD PO BOX 39100	INDIANAPOLIS IN 46239-9632
13764	MICRO PLASTICS INC	HWY 178 N	FLIPPIN AR 72634
2W944	PAPST MECHATRONIC CORP	AQUIDNECK INDUSTRIAL PK	NEWPORT RI 02840
73743	FISCHER SPECIAL MFG CO	111 INDUSTRIAL RD	COLD SPRING KY 41076-9749
80009	TEKTRONIX INC	14150 SW KARL BRAUN DR PO BOX 500	BEAVERTON OR 97077-0001
80126	PACIFIC ELECTRICORD CO	747 W REDONDO BEACH PO BOX 10	GARDENA CA 90247-4203

Replaceable mechanical parts list

Fig. & index number	Tektronix part number	Serial no. effective	Serial no. discont'd	Qty	Name & description	Mfr. code	Mfr. part number
1-1	200-4204-00			1	TOP COVER:ALUMINIUM,SPG422 *MOUNTING PARTS*	80009	200420400
-2	211-0538-00			18	SCREW,MACHINE:6-32 X 0.312,FLH,100 DEG,STL *END MOUNTING PARTS*	TK0435	ORDER BY DESC
-3	367-0437-03			1	HANDLE:ALUMINUM *MOUNTING PARTS*	OJ4C1	367-0437-03
-4	211-0538-00			2	SCREW,MACHINE:6-32 X 0.312,FLH,100 DEG,STL *END MOUNTING PARTS*	TK0435	ORDER BY DESC
-5	367-0437-01			1	HANDLE:ALUMINUM *MOUNTING PARTS*	OJ4C1	367-0437-01
-6	211-0538-00			2	SCREW,MACHINE:6-32 X 0.312,FLH,100 DEG,STL *END MOUNTING PARTS*	TK0435	ORDER BY DESC
-7	213-0216-00			1	THUMBSCREW:10-32 X 0.85,0.375 OD HD,SST	OKB01	213-0216-00
-8	354-0025-00			1	RING,RETAINING:EXTERNAL,U/O 0.187 DIA SFT	TK0941	555-18MI
-9	426-2512-00			1	FRONT FRAME:ALUMINIUM *MOUNTING PARTS*	80009	426251200
-10	211-0538-00			4	SCREW,MACHINE:6-32 X 0.312,FLH,100 DEG,STL *END MOUNTING PARTS*	TK0435	ORDER BY DESC
-11	333-4147-00			1	FRONT PANEL:ALUMINIUM,SPG422 *MOUNTING PARTS*	80009	333414700
-12	211-0012-00			10	SCREW,MACHINE:4-40 X 0.375,PNH,STL *END MOUNTING PARTS*	TK0435	ORDER BY DESC
-13				1	CKT BD ASSY:FRONT PANEL BOARD (SEE A1 REPL)	80009	671312700
-14	119-4809-00			1	DISPLAY MODULE:LCD:320 X 240,DOT MATRIX NTN SUPER TWIST,LED BACKLIGHT,96 X 72MM VIEWING AREA	TK0IU	DMC20261ANY-LY-
-15	378-0420-00			1	FILTER,DISPLAY:PLASTIC,SPG422	80009	378042000
-16				1	CKT BD ASSY:DIGITAL BOARD (SEE A2 REPL) *MOUNTING PARTS*		
-17	211-0661-00			12	SCR,ASSEM WSHR:4-40 X 0.25,PNH,STL,CD PL,POZ,MACH *END MOUNTING PARTS*	TK0435	ORDER BY DESC
-18	119-4699-00			1	OVEN ASSEMBLY:TG2000 *MOUNTING PARTS*	80009	119469900
-19	211-0661-00			2	SCR,ASSEM WSHR:4-40 X 0.25,PNH,STL,CD PL,POZ,MACH *END MOUNTING PARTS* OVEN ASSEMBLY INCLUDES:	TK0435	ORDER BY DESC
-20	200-4141-00			1	.COVER,TOP:POLYSTRNE,TG2000	80009	200414100
-21	432-0174-00			1	.COVER,BOTTOM:POLYSTYRNE,TG2000	80009	432017400
-22	348-1370-00			1	.GASKET:0.062,POLYURETHANE,TG2000	80009	348137000
-23	200-4140-00			1	.COVER,TOP:TG2000 *MOUNTING PARTS*	80009	200414000
-24	211-0001-00			2	.SCREW,MACHINE:2-56 X 0.25,PNH,STL *END MOUNTING PARTS*	TK0435	ORDER BY DESC

Replaceable mechanical parts list (Cont.)

Fig. & index number	Tektronix part number	Serial no. effective	Serial no. discontinued	Qty	Name & description	Mfr. code	Mfr. part number
-25	214-4578-00			1	.HOUSING,HT SK:ALUMINUM,TG2000	80009	214457800
-26	-----			1	.CIRCUIT BD ASSY:OSCILLATOR (SEE A2A1 REPL) *MOUNTING PARTS*		
-27	211-0661-00			2	.SCR,ASSY WSHR:4-40 X 0.25,PNH,STL,CD PL,PO.Z,MACH *END MOUNTING PARTS*	TK0435	ORDER BY DESC
-28	407-4287-00			1	.BRACKET,SUPPORT:0.040 ALUMINUM	80009	407428700
-29	337-3971-00			1	.SHIELD,ELEC:0.010 POLYCARBONATE,TG2000	80009	337397100
-30				1	CKT BD ASSY:OUTPUT BOARD (SEE A3 REPL) *MOUNTING PARTS*	80009	671312300
-31	211-0661-00			7	SCR,ASSEM WSHR:4-40 X 0.25,PNH,STL,CD PL,POZ,MACH	TK0435	ORDER BY DESC
-32	220-0497-00			4	NUT,PLAIN,HEX:0.5-28 X 0.562 HEX,BRS CD PL	73743	ORDER BY DESC
-33	210-1039-00			4	WASHER,LOCK:0.521 ID,INT,0.025 THK,SST *END MOUNTING PARTS*	0KB01	1224-02-00-0541
-34				1	CIRCUIT BD ASSY:REMOTE CONTROL FILTER (SEE A7 REPL) *MOUNTING PARTS*	80009	671-2059-00
-35	214-3903-01			2	SCREW,JACK:4-40 X 0.312 EXT THD,4-40 INT THD,0.188 HEX,STEEL,CADPLATE *END MOUNTING PARTS*	0KB01	214-3903-01
-36				1	CKT BD ASSY:BLACK GENERATOR (OPTION 01 ONLY) (SEE A5 REPL) *MOUNTING PARTS*	80009	671312500
-37	211-0661-00			6	SCR,ASSEM WSHR:4-40 X 0.25,PNH,STL,CD PL,POZ,MACH (OPTION 01 ONLY)	TK0435	ORDER BY DESC
-38	220-0497-00			4	NUT,PLAIN,HEX:0.5-28 X 0.562 HEX,BRS CD PL (OPTION 01 ONLY)	73743	ORDER BY DESC
-39	210-1039-00			4	WASHER,LOCK:0.521 ID,INT,0.025 THK,SST (OPTION 01 ONLY) *END MOUNTING PARTS*	0KB01	1224-02-00-0541
-40				1	CKT BD ASSY:TEST SIGNAL BOARD (OPTION 02 ONLY) (SEE A6 REPL)	80009	671-3126-01
-41	211-0661-00			5	SCR,ASSEM WSHR:4-40 X 0.25,PNH,STL,CD PL,POZ,MACH (OPTION 02 ONLY) *END MOUNTING PARTS*	TK0435	ORDER BY DESC
-42	407-4134-00			1	BRKT,FAN,MTG:SPG1000 *MOUNTING PARTS*	80009	407413400
-43	211-0538-00			2	SCREW,MACHINE:6-32 X 0.312,FLH,100 DEG,STL *END MOUNTING PARTS*	TK0435	ORDER BY DESC
-44	119-4270-00			1	FAN,TUBEAXIAL:12 VDC,2.6W,0.22A,4200 RPM,32DB, 16.6CFM,60X60MM,25MMTHICK,W/288MM LEADS & SLEEVE,W/CONNECT,FBA TYPE	2W944	612
-45	211-0619-00			1	SCREW,MACHINE:6-32 X 1.5,FLH,100 DEG,STL CDPL,POZ	TK0435	ORDER BY DESC
-46	210-0457-00			2	NUT,PL,ASSEM WA:6-32 X 0.312,STL CD PL *END MOUNTING PARTS*	TK0435	ORDER BY DESC

Replaceable mechanical parts list (Cont.)

Fig. & index number	Tektronix part number	Serial no. effective	Serial no. discont'd	Qty	Name & description	Mfr. code	Mfr. part number
-47	131-3573-00			1	CONN,PLUG,ELEC:MALE,W/LOCKING ADAPTER *MOUNTING PARTS*	80126	B-0779
-48	211-0014-00			2	SCREW,MACHINE:4-40 X 0.5,PNH,STL	TK0435	ORDER BY DESC
-49	337-3796-01			1	SHIELD,ELEC:0.032 BRASS,C26000,0.5 HARD *END MOUNTING PARTS*	80009	337379601
-50	671-3242-00			1	CKT BD ASSY:POWER SUPPLY BOARD *MOUNTING PARTS*	80009	671324200
-51	211-0661-00			6	SCR,ASSEM WSHR:4-40 X 0.25,PNH,STL,CD PL,POZ,MACH *END MOUNTING PARTS*	TK0435	ORDER BY DESC
-52	337-4012-00			1	SHEILD,ELECT:0.020 POLY,SPG422	80009	337401200
-53	134-0245-00			2	PLUG,BUTTON:0.156 THK X 0.375 DIA,BLACK NYLON	80009	134024500
-54	134-0246-00			4	PLUG,HOLE COVER:BUTTON PLUG;0.578 HEAD DIA X 0.406 THK,ACCOM 0.5 DIAHOLE,0.015-0.125THK PNL,NYLON, BLACK,94V-2	13764	62MP0500
-55	211-0177-00			1	SCREW,MACHINE:4-40 X 0.312,PNH,STL	TK0435	ORDER BY DESC
-56	351-0104-03			1	SL SECT,DWR EXT:12.625 L,W/O HARDWARE *MOUNTING PARTS*	06666	C-720-3 (WITHOU
-57	212-0158-00			8	SCREW,MACH:8-32 X 0.375,PNH,STL,CDPL,T-20 TORX DR	OKB01	ORDER BY DESC
-58	441-2062-00			1	CHASSIS:ALUMINUM	80009	441206200
	071-0034-00			1	STANDARD ACCESSORIES MANUAL,TECH:USERS,SPG422,DP	80009	071003400
-59	351-0859-00			1	TRK SL OUT SECT:STATIONARY & INTERMEDIATE SAFETY CONTROLLED	06666	CC3442-99-0005
-60	161-0216-00			1	CABLE ASSY,PWR:3,18 AWG,2.5M L,BLACK (STANDARD ONLY)	80126	C7120-25M-BL
	161-0215-00			1	OPTIONAL ACCESSORIES CABLE ASSY,PWR:3,0.75MU,2.5MM L,GREY (EUROPEAN OPTION A1 ONLY)	80126	0-5335-008-GY
	161-0066-10			1	CA ASSY,PWR:3,0.1MM SQ,250V/10A,2.5 METER,STR, IEC320,RCPT X 13A,FUSED UK PLUG(13A FUSE),UNITED KINGDOM,SAFTEY CONTROLLED (UNITED KINGDOM OPTION A2 ONLY)	S3109	BS/13-H05VVF3G0
	161-0066-11			1	CA ASSY,PWR:3,1.0MM SQ,250V/10A,2.5 METER,STR, IEC320,RCPT,AUSTRALIA,SAFTEY CONTROLLED (AUSTRALIAN OPTION A3 ONLY)	S3109	198-000
	161-0154-00			1	CA ASSY,PWR:3,1.0MM SQ,250V/10A,2.5 METER,STR, IEC320,RCPT,SWISS,SAFTEY CONTROLLED (SWISS OPTION A5 ONLY)	S3109	12-H05VVF3G 00-
	071-0035-02				MANUAL, TECH: SPG 422 SERVICE	80009	071003501

